



# Rules for the Classification of Ships

*Effective from 1 January 2024*

## Part F

# GENERAL CONDITIONS

## Definitions:

“Administration” means the Government of the State whose flag the Ship is entitled to fly or under whose authority the Ship is authorised to operate in the specific case.

“IACS” means the International Association of Classification Societies.

“Interested Party” means the party, other than the Society, having an interest in or responsibility for the Ship, product, plant or system subject to classification or certification (such as the owner of the Ship and his representatives, the ship builder, the engine builder or the supplier of parts to be tested) who requests the Services or on whose behalf the Services are requested.

“Owner” means the registered owner, the ship owner, the manager or any other party with the responsibility, legally or contractually, to keep the ship seaworthy or in service, having particular regard to the provisions relating to the maintenance of class laid down in Part A, Chapter 2 of the Rules for the Classification of Ships or in the corresponding rules indicated in the specific Rules.

“Rules” in these General Conditions means the documents below issued by the Society:

- (i) Rules for the Classification of Ships or other special units;
- (ii) Complementary Rules containing the requirements for product, plant, system and other certification or containing the requirements for the assignment of additional class notations;
- (iii) Rules for the application of statutory rules, containing the rules to perform the duties delegated by Administrations;
- (iv) Guides to carry out particular activities connected with Services;
- (v) Any other technical document, as for example rule variations or interpretations.

“Services” means the activities described in Article 1 below, rendered by the Society upon request made by or on behalf of the Interested Party.

“Ship” means ships, boats, craft and other special units, as for example offshore structures, floating units and underwater craft.

“Society” or “TASNEEF” means Tasneef and/or all the companies in the Tasneef Group which provide the Services.

“Surveyor” means technical staff acting on behalf of the Society in performing the Services.

## Article 1

1.1. The purpose of the Society is, among others, the classification and certification of ships and the certification of their parts and components. In particular, the Society:

- (i) sets forth and develops Rules;
- (ii) publishes the Register of Ships;
- (iii) issues certificates, statements and reports based on its survey activities.

1.2. The Society also takes part in the implementation of national and international rules and standards as delegated by various Governments.

1.3. The Society carries out technical assistance activities on request and provides special services outside the scope of classification, which are regulated by these general conditions, unless expressly excluded in the particular contract.

## Article 2

2.1. The Rules developed by the Society reflect the level of its technical knowledge at the time they are published. Therefore, the Society, although committed also through its research and development services to continuous updating of the Rules, does not guarantee the Rules meet state-of-the-art science and technology at the time of publication or that they meet the Society's or others' subsequent technical developments.

2.2. The Interested Party is required to know the Rules on the basis of which the Services are provided. With particular reference to Classification Services, special attention is to be given to the Rules concerning class suspension, withdrawal and reinstatement. In case of doubt or inaccuracy, the Interested Party is to promptly contact the Society for clarification.

The Rules for Classification of Ships are published on the Society's website: [www.tasneef.ae](http://www.tasneef.ae).

2.3. The Society exercises due care and skill:

- (i) in the selection of its Surveyors
- (ii) in the performance of its Services, taking into account the level of its technical knowledge at the time the Services are performed.

2.4. Surveys conducted by the Society include, but are not limited to, visual inspection and non-destructive testing. Unless otherwise required, surveys are conducted through sampling techniques and do not consist of comprehensive verification or monitoring of the Ship or of the items subject to certification. The surveys and checks made by the Society on board ship do not necessarily require the constant and continuous presence of the Surveyor. The Society may also commission laboratory testing, underwater inspection and other checks carried out by and under the responsibility of qualified service suppliers. Survey practices and procedures are selected by the Society based on its experience and knowledge and according to generally accepted technical standards in the sector.

## Article 3

3.1. The class assigned to a Ship, like the reports, statements, certificates or any other document or information issued by the Society, reflects the opinion of the Society concerning compliance, at the time the Service is provided, of the Ship or product subject to certification, with the applicable Rules (given the intended use and within the relevant time frame).

The Society is under no obligation to make statements or provide information about elements or facts which are not part of the specific scope of the Service requested by the Interested Party or on its behalf.

3.2. No report, statement, notation on a plan, review, Certificate of Classification, document or information issued or given as part of the Services provided by the Society shall have any legal effect or implication other than a representation that, on the basis of the checks made by the Society, the Ship, structure, materials, equipment, machinery or any other item covered by such document or information meet the Rules. Any such document is issued solely for the use of the Society, its committees and clients or other duly authorised bodies and for no other purpose. Therefore, the Society cannot be held liable for any act made or document issued by other parties on the basis of the statements or information given by the Society. The validity, application, meaning and interpretation of a Certificate of Classification, or any other document or information issued by the Society in connection with its Services, is governed by the Rules of the Society, which is the sole subject entitled to make such interpretation. Any disagreement on technical matters between the Interested Party and the Surveyor in the carrying out of his functions shall be raised in writing as soon as possible with the Society, which will settle any divergence of opinion or dispute.

3.3. The classification of a Ship, or the issuance of a certificate or other document connected with classification or certification and in general with the performance of Services by the Society shall have the validity conferred upon it by the Rules of the Society at the time of the assignment of class or issuance of the certificate; in no case shall it amount to a statement or warranty of seaworthiness,

structural integrity, quality or fitness for a particular purpose or service of any Ship, structure, material, equipment or machinery inspected or tested by the Society.

3.4. Any document issued by the Society in relation to its activities reflects the condition of the Ship or the subject of certification or other activity at the time of the check.

3.5. The Rules, surveys and activities performed by the Society, reports, certificates and other documents issued by the Society are in no way intended to replace the duties and responsibilities of other parties such as Governments, designers, ship builders, manufacturers, repairers, suppliers, contractors or sub-contractors, Owners, operators, charterers, underwriters, sellers or intended buyers of a Ship or other product or system surveyed.

These documents and activities do not relieve such parties from any fulfilment, warranty, responsibility, duty or obligation (also of a contractual nature) expressed or implied or in any case incumbent on them, nor do they confer on such parties any right, claim or cause of action against the Society. With particular regard to the duties of the ship Owner, the Services undertaken by the Society do not relieve the Owner of his duty to ensure proper maintenance of the Ship and ensure seaworthiness at all times. Likewise, the Rules, surveys performed, reports, certificates and other documents issued by the Society are intended neither to guarantee the buyers of the Ship, its components or any other surveyed or certified item, nor to relieve the seller of the duties arising out of the law or the contract, regarding the quality, commercial value or characteristics of the item which is the subject of transaction.

In no case, therefore, shall the Society assume the obligations incumbent upon the above-mentioned parties, even when it is consulted in connection with matters not covered by its Rules or other documents.

In consideration of the above, the Interested Party undertakes to relieve and hold harmless the Society from any third party claim, as well as from any liability in relation to the latter concerning the Services rendered.

Insofar as they are not expressly provided for in these General Conditions, the duties and responsibilities of the Owner and Interested Parties with respect to the services rendered by the Society are described in the Rules applicable to the specific Service rendered.

#### **Article 4**

4.1. Any request for the Society's Services shall be submitted in writing and signed by or on behalf of the Interested Party. Such a request will be considered irrevocable as soon as received by the Society and shall entail acceptance by the applicant of all relevant requirements of the Rules, including these General Conditions. Upon acceptance of the written request by the Society, a contract between the Society and the Interested Party is entered into, which is regulated by the present General Conditions.

4.2. In consideration of the Services rendered by the Society, the Interested Party and the person requesting the service shall be jointly liable for the payment of the relevant fees, even if the service is not concluded for any cause not pertaining to the Society. In the latter case, the Society shall not be held liable for non-fulfilment or partial fulfilment of the Services requested. In the event of late payment, interest at the legal current rate increased by 1.5% may be demanded.

4.3. The contract for the classification of a Ship or for other Services may be terminated and any certificates revoked at the request of one of the parties, subject to at least 30 days' notice to be given in writing. Failure to pay, even in part, the fees due for Services carried out by the Society will entitle the Society to immediately terminate the contract and suspend the Services.

For every termination of the contract, the fees for the activities performed until the time of the termination shall be owed to the Society as well as the expenses incurred in view of activities already programmed; this is without prejudice to the right to compensation due to the Society as a consequence of the termination.

With particular reference to Ship classification and certification, unless decided otherwise by the Society, termination of the contract implies that the assignment of class to a Ship is withheld or, if already assigned, that it is suspended or withdrawn; any statutory certificates issued by the Society will be withdrawn in those cases where provided for by agreements between the Society and the flag State.

#### **Article 5**

5.1. In providing the Services, as well as other correlated information or advice, the Society, its Surveyors, servants or agents operate with due diligence for the proper execution of the activity. However, considering the nature of the activities performed (see art. 2.4), it is not possible to guarantee absolute accuracy, correctness and completeness of any information or advice supplied. Express and implied warranties are specifically disclaimed.

Therefore, except as provided for in paragraph 5.2 below, and also in the case of activities carried out by delegation of Governments, neither the Society nor any of its Surveyors will be liable for any loss, damage or expense of whatever nature sustained by any person, in tort or in contract, derived from carrying out the Services.

5.2. Notwithstanding the provisions in paragraph 5.1 above, should any user of the Society's Services prove that he has suffered a loss or damage due to any negligent act or omission of the Society, its Surveyors, servants or agents, then the Society will pay compensation to such person for his proved loss, up to, but not exceeding, five times the amount of the fees charged for the specific services, information or opinions from which the loss or damage derives or, if no fee has been charged, a maximum of AED5,000 (Arab Emirates Dirhams Five Thousand only). Where the fees charged are related to a number of Services, the amount of the fees will be apportioned for the purpose of the calculation of the maximum compensation, by reference to the estimated time involved in the performance of the Service from which the damage or loss derives. Any liability for indirect or consequential loss, damage or expense is specifically excluded. In any case, irrespective of the amount of the fees charged, the maximum damages payable by the Society will not be more than AED5,000,000 (Arab Emirates Dirhams Five Millions only). Payment of compensation under this paragraph will not entail any admission of responsibility and/or liability by the Society and will be made without prejudice to the disclaimer clause contained in paragraph 5.1 above.

5.3. Any claim for loss or damage of whatever nature by virtue of the provisions set forth herein shall be made to the Society in writing, within the shorter of the following periods: (i) THREE (3) MONTHS from the date on which the Services were performed, or (ii) THREE (3) MONTHS from the date on which the damage was discovered. Failure to comply with the above deadline will constitute an absolute bar to the pursuit of such a claim against the Society.

#### **Article 6**

6.1. These General Conditions shall be governed by and construed in accordance with United Arab Emirates (UAE) law, and any dispute arising from or in connection with the Rules or with the Services of the Society, including any issues concerning responsibility, liability or limitations of liability of the Society, shall be determined in accordance with UAE law. The courts of the Dubai International Financial Centre (DIFC) shall have exclusive jurisdiction in relation to any claim or dispute which may arise out of or in connection with the Rules or with the Services of the Society.

6.2. However,

- (i) In cases where neither the claim nor any counterclaim exceeds the sum of AED300,000 (Arab Emirates Dirhams Three Hundred Thousand) the dispute shall be referred to the jurisdiction of the DIFC Small Claims Tribunal; and
- (ii) for disputes concerning non-payment of the fees and/or expenses due to the Society for services, the Society shall have the

right to submit any claim to the jurisdiction of the Courts of the place where the registered or operating office of the Interested Party or of the applicant who requested the Service is located.

In the case of actions taken against the Society by a third party before a public Court, the Society shall also have the right to summon the Interested Party or the subject who requested the Service before that Court, in order to be relieved and held harmless according to art. 3.5 above.

#### **Article 7**

**7.1.** All plans, specifications, documents and information provided by, issued by, or made known to the Society, in connection with the performance of its Services, will be treated as confidential and will not be made available to any other party other than the Owner without authorisation of the Interested Party, except as provided for or required by any applicable international, European or domestic legislation, Charter or other IACS resolutions, or order from a competent authority. Information about the status and validity of class and statutory certificates, including transfers, changes, suspensions, withdrawals of class, recommendations/conditions of class, operating conditions or restrictions issued against classed ships and other related information, as may be required, may be published on the website or released by other means, without the prior consent of the Interested Party.

Information about the status and validity of other certificates and statements may also be published on the website or released by other means, without the prior consent of the Interested Party.

**7.2.** Notwithstanding the general duty of confidentiality owed by the Society to its clients in clause 7.1 above, the Society's clients hereby accept that the Society may participate in the IACS Early Warning System which requires each Classification Society to provide other involved Classification Societies with relevant technical information on serious hull structural and engineering systems failures, as defined in the IACS Early Warning System (but not including any drawings relating to the ship which may be the specific property of another party), to enable such useful information to be shared and used to facilitate the proper working of the IACS Early Warning System. The Society will provide its clients with written details of such information sent to the involved Classification Societies.

**7.3.** In the event of transfer of class, addition of a second class or withdrawal from a double/dual class, the Interested Party undertakes to provide or to permit the Society to provide the other Classification Society with all building plans and drawings, certificates, documents and information relevant to the classed unit, including its history file, as the other Classification Society may require for the purpose of classification in compliance with the applicable legislation and relative IACS Procedure. It is the Owner's duty to ensure that, whenever required, the consent of the builder is obtained with regard to the provision of plans and drawings to the new Society, either by way of appropriate stipulation in the building contract or by other agreement.

In the event that the ownership of the ship, product or system subject to certification is transferred to a new subject, the latter shall have the right to access all pertinent drawings, specifications, documents or information issued by the Society or which has come to the knowledge of the Society while carrying out its Services, even if related to a period prior to transfer of ownership.

#### **Article 8**

**8.1.** Should any part of these General Conditions be declared invalid, this will not affect the validity of the remaining provisions.

## EXPLANATORY NOTE TO PART F

### 1. Reference edition

The reference edition for Part F is the Tasneef Rules 2000 edition, which is effective from 1 June 2000.

### 2. Amendments after the reference edition

2.1 Tasneef Rules 2000 has been completely rewritten and reorganised.

2.2 Except in particular cases, the Rules are updated and published annually.

### 3. Effective date of the requirements

3.1 All requirements in which new or amended provisions with respect to those contained in the reference edition have been introduced are followed by a date shown in brackets.

The date shown in brackets is the effective date of entry into force of the requirements as amended by the last updating. The effective date of all those requirements not followed by any date shown in brackets is that of the reference edition.

3.2 Item 6 below provides a summary of the technical changes from the preceding edition. In general, this list does not include those items to which only editorial changes have been made not affecting the effective date of the requirements contained therein.

### 4. Rule Variations and Corrigenda

Until the next edition of the Rules is published, Rule Variations and/or corrigenda, as necessary, will be published on the Tasneef web site ([www.Tasneef.org](http://www.Tasneef.org)). Except in particular cases, paper copies of Rule Variations or corrigenda are not issued.

### 5. Rule subdivision and cross-references

#### 5.1 Rule subdivision

The Rules are subdivided into six parts, from A to F.

Part A: Classification and Surveys

Part B: Hull and Stability

Part C: Machinery, Systems and Fire Protection

Part D: Materials and Welding

Part E: Service Notations

Part F: Additional Class Notations

Each Part consists of:

- Chapters
- Sections and possible Appendices
- Articles
- Sub-articles
- Requirements

Figures (abbr. Fig) and Tables (abbr. Tab) are numbered in ascending order within each Section or Appendix.

#### 5.2 Cross-references

Examples: Pt A, Ch 1, Sec 1, [3.2.1] or Pt A, Ch 1, App 1, [3.2.1]

- Pt A means Part A

The part is indicated when it is different from the part in which the cross-reference appears. Otherwise, it is not indicated.

- Ch 1 means Chapter 1

The Chapter is indicated when it is different from the chapter in which the cross-reference appears. Otherwise, it is not indicated.

- Sec 1 means Section 1 (or App 1 means Appendix 1)

The Section (or Appendix) is indicated when it is different from the Section (or Appendix) in which the cross-reference appears. Otherwise, it is not indicated.

- [3.2.1] refers to requirement 1, within sub-article 2 of article 3.

Cross-references to an entire Part or Chapter are not abbreviated as indicated in the following examples:

- Part A for a cross-reference to Part A
- Part A, Chapter 1 for a cross-reference to Chapter 1 of Part A.

**6. Summary of amendments introduced in the edition effective from 1 January 2024**

**Foreword**

This edition of Part F contains amendments whose effective date is **1 January 2024**.

The date of entry into force of each new or amended item is shown in brackets after the number of the item concerned.

## Part F Additional Class Notations

### Chapters 1 2 3 4 5 6 7 **8 9 10 11 12 13**

---

CHAPTER 1	SYSTEM OF TRACE AND ANALYSIS OF RECORDS (STAR)
CHAPTER 2	AVAILABILITY OF MACHINERY (AVM)
CHAPTER 3	AUTOMATION SYSTEMS (AUT)
CHAPTER 4	INTEGRATED SHIP SYSTEMS
CHAPTER 5	MONITORING EQUIPMENT (MON)
CHAPTER 6	COMFORT ON BOARD (COMF)
CHAPTER 7	POLLUTION PREVENTION (CLEAN)
<b>CHAPTER 8</b>	<b>REFRIGERATING INSTALLATIONS (REEFER)</b>
<b>CHAPTER 9</b>	<b>ICE CLASS (ICE)</b>
<b>CHAPTER 10</b>	<b>POLAR CLASS (POLAR)</b>
<b>CHAPTER 11</b>	<b>WINTERIZATION</b>
<b>CHAPTER 12</b>	<b>PLANNED MAINTENANCE SYSTEM AND CONDITION BASED MAINTENANCE (PMS/CBM)</b>
<b>CHAPTER 13</b>	<b>OTHER ADDITIONAL CLASS NOTATIONS</b>





# CHAPTER 8

## REFRIGERATING INSTALLATIONS (REEFER)

### Section 1 General Requirements

<b>1</b>	<b>General</b>	<b>41</b>
	1.1 Application	
	1.2 Temperature conditions	
	1.3 Definitions	
<b>2</b>	<b>Design criteria</b>	<b>42</b>
	2.1 Reference conditions	
<b>3</b>	<b>Documentation</b>	<b>42</b>
	3.1 Refrigerating installations	
	3.2 Controlled atmosphere installations	
<b>4</b>	<b>General technical requirements</b>	<b>42</b>
	4.1 Refrigerating unit availability	
	4.2 Refrigeration of chambers	
	4.3 Defrosting	
	4.4 Prime movers and sources of power	
	4.5 Pumps	
	4.6 Sea connections	
	4.7 Refrigerating machinery spaces	
	4.8 Exemptions for small plants	
	4.9 Personnel safety	
<b>5</b>	<b>Refrigerated chambers</b>	<b>45</b>
	5.1 Construction of refrigerated chambers	
	5.2 Penetrations	
	5.3 Access to refrigerated spaces	
	5.4 Insulation of refrigerated chambers	
	5.5 Characteristics of insulation	
	5.6 Miscellaneous requirements	
	5.7 Installation of the insulation	
	5.8 Drainage of refrigerated spaces	
<b>6</b>	<b>Refrigerants</b>	<b>47</b>
	6.1 General	
	6.2 Rated working pressures	
<b>7</b>	<b>Refrigerating machinery and equipment</b>	<b>48</b>
	7.1 General requirements for prime movers	
	7.2 Common requirements for compressors	
	7.3 Reciprocating compressors	
	7.4 Screw compressor bearings	
	7.5 Pressure vessels	
	7.6 General requirements for piping	
	7.7 Accessories	
	7.8 Refrigerating plant overpressure protection	
<b>8</b>	<b>Specific requirements for direct and indirect refrigerating systems</b>	<b>49</b>
	8.1 Specific requirements for refrigerating systems	

8.2	Specific requirements for air cooling systems and distribution and renewal of air in cargo spaces	
<b>9</b>	<b>Instrumentation, alarm, monitoring</b>	<b>50</b>
9.1	General	
9.2	Instrumentation, alarm and monitoring arrangement	
<b>10</b>	<b>Material tests, inspection and testing, certification</b>	<b>51</b>
10.1	General	
10.2	Material testing	
10.3	Shop tests	
10.4	Pressure tests at the workshop	
10.5	Thermometers and manometers	
10.6	Shipboard tests	
10.7	Defrosting system	

## **Section 2 Additional Requirements for the Notation REF-CARGO**

<b>1</b>	<b>General</b>	<b>54</b>
1.1	Application	
1.2	Refrigeration of cargo spaces	
1.3	Heating	
<b>2</b>	<b>Steels for hull structure</b>	<b>54</b>
2.1	Grades of steel	
<b>3</b>	<b>Refrigerated cargo spaces</b>	<b>54</b>
3.1	Insulation	
<b>4</b>	<b>Instrumentation</b>	<b>54</b>
4.1	Thermometers in cargo spaces	
<b>5</b>	<b>Additional requirements for AIRCONT notation</b>	<b>55</b>
5.1	General	
5.2	Controlled atmosphere cargo spaces and adjacent spaces	
5.3	Gas systems	
5.4	Miscellaneous equipment	
5.5	Gas detection and monitoring equipment	
5.6	Instrumentation, alarm and monitoring arrangement	
5.7	Safety	
5.8	Tests and trials	
<b>6</b>	<b>Additional requirements for PRECOOLING and QUICKFREEZE notations</b>	<b>60</b>
6.1	General	
6.2	Shipboard tests	

## **Section 3 Additional Requirements for the Notation REF-CONT**

<b>1</b>	<b>General</b>	<b>61</b>
1.1	Application	

<b>2</b>	<b>Refrigerating plants supplying refrigerated air to containers</b>	<b>61</b>
2.1	Definitions	
2.2	Cold distribution	
2.3	Equipment and systems	
2.4	Thermometers	
2.5	Workshop and shipboard inspections and tests	
2.6	Temperature measuring and recording devices	
2.7	Shipboard tests	
<b>3</b>	<b>Ships supplying electrical power to self-refrigerated containers</b>	<b>64</b>
3.1	Electrical equipment	
3.2	Installation of containers	

## **Section 4 Additional Requirements for the Notation REF-STORE**

<b>1</b>	<b>General</b>	<b>65</b>
1.1	Application	

# CHAPTER 9

## ICE CLASS (ICE)

### Section 1 General

1	General	69
1.1	Application	
1.2	Owner's responsibility	
2	Ice class draughts and ice thickness	69
2.1	Definitions	
2.2	Draught limitations	
2.3	Ice thickness	
3	Output of propulsion machinery	71
3.1	Required engine output	

### Section 2 Hull and Stability

1	Definitions	74
1.1	Ice strengthened area	
1.2	Regions	
2	Steels for hull structure	75
2.1	Grades of steel	
3	Structure design principles	75
3.1	General framing arrangement	
3.2	Transverse framing arrangement	
3.3	Bilge keels	
4	Design loads	77
4.1	General	
4.2	Ice loads	
5	Hull scantlings	78
5.1	Plating	
5.2	Ordinary stiffeners	
5.3	Primary supporting members	
6	Other structures	81
6.1	Application	
6.2	Fore part	
6.3	Aft part	
6.4	Deck strips and hatch covers	
6.5	Sidescuttles and freeing ports	
7	Hull outfitting	82
7.1	Rudders and steering arrangements	
7.2	Bulwarks	

## Section 3 Machinery

<b>1</b>	<b>Propulsion</b>	<b>84</b>
	1.1 Propulsion machinery performance	
<b>2</b>	<b>Class notations IAS, IA, IB and IC</b>	<b>84</b>
	2.1 Propulsion machinery	
	2.2 Symbols	
	2.3 Design ice conditions	
	2.4 Materials	
	2.5 Design loads	
	2.6 Design	
	2.7 Alternative design procedure	
	2.8 Starting arrangements for propulsion machinery	
<b>3</b>	<b>Class notation ID</b>	<b>104</b>
	3.1 Ice torque	
	3.2 Propellers	
	3.3 Shafting	
<b>4</b>	<b>Miscellaneous requirements</b>	<b>105</b>
	4.1 Sea inlets and cooling water systems of machinery	
	4.2 Systems to prevent ballast water from freezing	
	4.3 Steering gear	
	4.4 Fire pumps	

# CHAPTER 10

## POLAR CLASS (POLAR)

### Section 1 General

1	General	109
1.1	Application	
2	Ice waterlines	109
2.1	Definitions	
2.2	Indication of upper and lower ice waterlines	

### Section 2 Hull

1	General	111
1.1	Definitions	
1.2	Hull areas	
1.3	Direct calculations	
2	Materials and welding	113
2.1	Material classes and grades	
2.2	Welding	
3	Corrosion/abrasion additions and steel renewal	114
3.1	Corrosion/abrasion addition	
3.2	Steel renewal	
4	Design ice loads	114
4.1	General	
4.2	Glancing impact load characteristics	
4.3	Bow area	
4.4	Hull areas other than the bow	
4.5	Design load patch	
4.6	Pressure within the design load patch	
4.7	Hull area factors	
5	Longitudinal strength	119
5.1	Application	
5.2	Hull girder ice loads	
5.3	Longitudinal strength criteria	
6	Shell plating	120
6.1	Definitions	
6.2	Required thickness	
6.3	Net thickness	
7	Framing	122
7.1	General	
7.2	Actual net effective shear area	
7.3	Actual net effective plastic section modulus	
7.4	Ordinary stiffeners in bottom and in transversely stiffened side structures	
7.5	Longitudinal ordinary stiffeners in side structures	

	7.6	Web frames and load-carrying stringers	
	7.7	Framing - Structural stability	
<b>8</b>		<b>Plated structures</b>	<b>125</b>
	8.1		
	8.2		
	8.3		
<b>9</b>		<b>Stem and stern arrangement</b>	<b>125</b>
	9.1	Fore part	
	9.2	Aft part	
<b>10</b>		<b>Hull outfitting</b>	<b>126</b>
	10.1	Appendages	
	10.2	Rudders and steering arrangements	
	10.3	Arrangements for towing	

### **Section 3 Machinery**

<b>1</b>		<b>General</b>	<b>127</b>
	1.1	Application	
	1.2	Drawings and particulars to be submitted	
	1.3	System Design	
<b>2</b>		<b>Materials</b>	<b>127</b>
	2.1	Materials exposed to sea water	
	2.2	Materials exposed to sea water temperature	
	2.3	Material exposed to low air temperature	
<b>3</b>		<b>Ice interaction load</b>	<b>127</b>
	3.1	Propeller ice interaction	
	3.2	Ice Class factors	
	3.3	Design ice loads for open propeller	
	3.4	Design ice loads for ducted propeller	
	3.5	Design loads on propulsion line	
<b>4</b>		<b>Design</b>	<b>131</b>
	4.1	Design principle	
	4.2	Azimuthing main propulsors	
	4.3	Blade design	
	4.4	Prime movers	
<b>5</b>		<b>Machinery fastening loading accelerations</b>	<b>132</b>
	5.1	General	
	5.2	Accelerations	
<b>6</b>		<b>Auxiliary systems</b>	<b>132</b>
	6.1	General	
<b>7</b>		<b>Sea inlets and cooling water systems</b>	<b>133</b>
	7.1	General	
<b>8</b>		<b>Ballast tanks</b>	<b>133</b>
	8.1	General	

9	Ventilation system	133
	9.1 General	
10	Alternative design	133
	10.1 General	



# CHAPTER 11

## WINTERIZATION

### Section 1 General

1	General	139
1.1	Purpose and application	
2	Design temperature	139
2.1	Definitions	
3	Required notations	139
3.1		
4	Documentation to be submitted	140
4.1		

### Section 2 Hull and Stability

1	Structure Design Principles	141
1.1	Extention of inner hull	
1.2	Materials	
1.3	Anchors	
2	Stability	141
2.1	General	
2.2	Intact stability	
2.3	Ships with DMS notation	
2.4	Subdivision and arrangement	

### Section 3 Machinery and Systems

1	Propellers	142
1.1		
1.2	Equipment located in the machinery space	
2	Heating of spaces	142
2.1		
3	Windows	142
3.1		
4	Sea inlets	142
4.1		
5	Ventilation inlets	142
5.1		

## **Section 4 Anti-icing, De-icing, Anti-freezing**

1	Anti-icing	143
	1.1 General	
2	De-icing	143
	2.1 General	
3	Anti-freezing	143
	3.1 General	
4	Electric equipment for anti-icing, de-icing, anti-freezing	144
	4.1	
5	Arrangements based on heating by fluids	144
	5.1	
6	Testing	144
	6.1	
7	Special equipment	144
	7.1	

# CHAPTER 12

## PLANNED MAINTENANCE SYSTEM AND CONDITION BASED MAINTENANCE (PMS/CBM)

### Section 1 Planned Maintenance System

1	General	147
	1.1 Application	
	1.2 Maintenance intervals	
	1.3 Shipboard responsibility	
2	Conditions and procedures for the approval of the system	147
	2.1 General	
	2.2 System requirements	
	2.3 PMS Description	
3	Implementation of the system and approval validity	148
	3.1	
4	Surveys	149
	4.1 Installation Survey	
	4.2 Implementation Survey	
	4.3 Annual Audit of the PMS	
5	Damage and repairs	150
	5.1	
6	Machinery survey in accordance with a Condition Based Maintenance program	150
	6.1 Definitions	
	6.2 General on Condition Based Maintenance	
	6.3 Roles and Responsibilities	
	6.4 CBM criteria for main machinery	
	6.5 Miscellaneous systems and equipment	

### Section 2 Condition Based Maintenance Of The Propulsion System (PMS-CM(PROP))

1	General	160
	1.1 Application	
	1.2 Scope of PMS-CM(PROP) Notation	
	1.3 Documentation for Approval	
	1.4 Implementation of the CBM	
	1.5 Surveys	

**Section 3 Condition Based Maintenance Of The Heating Ventilation and Air Conditioning (PMS-CM(HVAC))**

1 General 161

---

- 1.1 Application
- 1.2 Scope and requirements of PMS-CM(HVAC) Notation
- 1.3 Documentation for Approval
- 1.4 Implementation of the CBM
- 1.5 Surveys

**Section 4 Condition Based Maintenance Of The Cargo System (PMS-CM(CARGO))**

1 General 162

---

- 1.1 Application
- 1.2 Scope and requirements of PMS-CM(CARGO) Notation
- 1.3 Documentation for Approval
- 1.4 Implementation of the CBM
- 1.5 Surveys

**Section 5 Condition Based Maintenance Of The Electrical Switchboards (PMS-CM(ELE))**

1 General 163

---

- 1.1 Application
- 1.2 Scope and requirements of PMS-CM(ELE) Notation
- 1.3 Documentation for Approval
- 1.4 Implementation of the CBM
- 1.5 Surveys

**Section 6 Condition Based Maintenance Of The Fire Detection System (PMS-CM(FDS))**

1 General 164

---

- 1.1 Application
- 1.2 Scope and requirements of PMS-CM(FDS) Notation
- 1.3 Documentation for Approval
- 1.4 Implementation of the CBM
- 1.5 Surveys

**Section 7 Condition Based Maintenance Of Machinery Items (PMS-CM)**

1 General 165

---

- 1.1 Application
- 1.2 Scope and requirements of PMS-CM Notation
- 1.3 Documentation for Approval
- 1.4 Implementation of the CBM
- 1.5 Surveys

# CHAPTER 13

## OTHER ADDITIONAL CLASS NOTATIONS

### Section 1 Strengthened Bottom (STRENGTHBOTTOM-NAABSA)

1	General	169
	1.1 Application	
2	Double bottom	169
	2.1 Ships with L < 90 m and longitudinally framed double bottom	
	2.2 Ships with L < 90 m and transversely framed double bottom	
	2.3 Ships with L ≥ 90 m and ships with L < 90 m subject to specific loads when properly stranded	
3	Single bottom	170
	3.1 Scantlings	

### Section 2 Grab Loading (GRABLOADING and GRAB [x] )

1	General	171
	1.1 Application	
2	Class notation GRABLOADING	171
	2.1 Inner bottom plating	
3	Class notation GRAB [X]	171
	3.1 Symbols	
	3.2 Plating	

### Section 3 In-Water Survey Arrangements (INWATERSURVEY)

1	General	172
	1.1 Application	
	1.2 Documentation to be submitted	
2	Structure design principles	172
	2.1	

### Section 4 Single Point Mooring (SPM)

1	General	173
	1.1 Application	

<b>2</b>	<b>Documentation</b>	<b>173</b>
	2.1 Documentation for approval	
	2.2 Documentation for information	
<b>3</b>	<b>General arrangement</b>	<b>173</b>
	3.1 General provision	
	3.2 Typical layout	
	3.3 Equipment	
<b>4</b>	<b>Number and safe working load of chain stoppers</b>	<b>173</b>
	4.1 General	
<b>5</b>	<b>Mooring components</b>	<b>174</b>
	5.1 Bow chain stopper	
	5.2 Bow fairleads	
	5.3 Pedestal roller fairleads	
	5.4 Winches or capstans	
	5.5 Type approval	
<b>6</b>	<b>Supporting hull structures</b>	<b>177</b>
	6.1 General	
<b>7</b>	<b>Strength criteria</b>	<b>177</b>
	7.1 General	

## **Section 5 Container Lashing Equipment (LASHING)**

<b>1</b>	<b>General</b>	<b>178</b>
	1.1 Application	
	1.2 Documents to be kept on board	
	1.3 Materials	
<b>2</b>	<b>Arrangements of containers</b>	<b>178</b>
	2.1 General	
	2.2 Stowage in holds using removable cell guides	
	2.3 Stowage under deck without cell guides	
	2.4 Stowage on exposed deck	
	2.5 Uniform line load stowage on deck or hatch covers	
<b>3</b>	<b>Procedure for the assignment of the notation</b>	<b>181</b>
	3.1 Approval of the mobile lashing equipment	
	3.2 Type tests	
	3.3 Inspection at works of the mobile lashing equipment	
	3.4 Reception of board of the mobile lashing equipment	
	3.5 Approval of lashing software	
<b>4</b>	<b>Forces applied to containers</b>	<b>185</b>
	4.1 General	
	4.2 Definitions	
	4.3 Still water and inertial forces	
	4.4 Route Dependent Factor FR for specific sea routes	
	4.5 Wind forces	
	4.6 Forces imposed by lashing and securing arrangements	
	4.7 Sea pressure	

<b>5</b>	<b>Determination of loads in lashing equipment and in container frames</b>	<b>190</b>
5.1	Calculation hypothesis	
5.2	Distribution of forces	
5.3	Containers only secured by locking devices	
5.4	Containers secured by means of lashings or buttresses	
5.5	Stiffnesses	
<b>6</b>	<b>Strength criteria</b>	<b>191</b>
6.1	Permissible loads on containers	
6.2	Permissible loads induced by lashing on container corners	
6.3	Permissible loads on lashing equipment	
6.4	Permissible stresses on cell guides	

## **Section 6 Dynamic Positioning (DYNAPOS)**

<b>1</b>	<b>General</b>	<b>194</b>
1.1	Application	
1.2	Definitions	
1.3	Dynamic positioning sub-systems	
<b>2</b>	<b>Documentation to be submitted</b>	<b>196</b>
2.1		
<b>3</b>	<b>Functional requirements</b>	<b>199</b>
3.1	General	
3.2	Power system	
3.3	Thruster system	
3.4	DP Control system	
3.5	Computer system	
3.6	Position reference system	
3.7	Ship sensors	
<b>4</b>	<b>Power supply system</b>	<b>203</b>
4.1		
<b>5</b>	<b>Cables and piping systems</b>	<b>205</b>
5.1		
<b>6</b>	<b>Alarm and Monitoring System</b>	<b>205</b>
6.1		
<b>7</b>	<b>Software</b>	<b>206</b>
7.1		
<b>8</b>	<b>Operational requirements</b>	<b>206</b>
8.1	General	
<b>9</b>	<b>Testing</b>	<b>206</b>
9.1	General	
9.2	Type approved components	
9.3	Sea trials	
9.4	FMEA proving trials	
<b>10</b>	<b>Station keeping capability feature SKC</b>	<b>207</b>
10.1	Definition	

10.2	Documentation to be submitted	
10.3	Standard environmental conditions	
10.4	Site specific environmental conditions	
10.5	Assessment of the forces	
<b>11</b>	<b>DP PLUS notation</b>	<b>209</b>

- 
- 11.1 Application
  - 11.2 General
  - 11.3 Functional requirements for DFS notation
  - 11.4 Functional requirements for FFP notation
  - 11.5 Functional requirements for PRD notation
  - 11.6 FMEA proving trials

## **Section 7 Vapour Control System (VCS)**

<b>1</b>	<b>General</b>	<b>214</b>
1.1	Application	
1.2	Definitions	
1.3	Documentation to be submitted	
<b>2</b>	<b>Vapour system</b>	<b>215</b>
2.1	General	
2.2	Vapour manifold	
2.3	Vapour hoses	
2.4	Vapour overpressure and vacuum protection	
<b>3</b>	<b>Instrumentation</b>	<b>217</b>
3.1	Cargo tank gauging equipment	
3.2	Cargo tank high level alarms	
3.3	Cargo tank overfill alarms	
3.4	High and low vapour pressure alarms	
<b>4</b>	<b>Instruction manual</b>	<b>217</b>
4.1	General	
4.2	Content	
<b>5</b>	<b>Testing and trials</b>	<b>218</b>
5.1		
5.2	On board trials	
<b>6</b>	<b>Additional requirements for "TRANSFER" notation</b>	<b>218</b>
6.1	Application	
6.2	Equipment	

## **Section 8 Cofferdam Ventilation (COVENT)**

<b>1</b>	<b>General</b>	<b>219</b>
1.1	Application	
1.2	Documents to be submitted	
<b>2</b>	<b>Design and construction</b>	<b>219</b>
2.1	Arrangement	
2.2	Other technical requirements	



3	Inspections and testings	220
3.1	Equipment and systems	
3.2	Testing on board	

## **Section 9 Centralised Cargo and Ballast Water Handling Installations (CARGOCONTROL)**

1	General	221
1.1	Application	
1.2	Documents to be submitted	
2	Design and construction requirements	221
2.1	Control station	
2.2	Remote control, indication and alarm systems	
3	Inspections and testings	222
3.1	Equipment and systems	
3.2	Testing on board	

## **Section 10 Ship Manoeuvrability (MANOVR)**

1	General	223
1.1	Application	
1.2	Manoeuvres evaluation	
2	Definitions	223
2.1	Geometry of the ship	
2.2	Standard manoeuvres and associated terminology	
3	Requirements	224
3.1	Foreword	
3.2	Conditions at which the requirements apply	
3.3	Criteria for manoeuvrability evaluation	
4	Additional considerations	224
4.1	Trials in different conditions	
4.2	Dynamic instability	

## **Section 11 Damage Stability (DMS)**

1	General	225
1.1		
1.2	Documents to be submitted	
2	Requirements applicable to all type of ships	225
2.1	Approaches to be followed for damage stability investigation	
3	Additional requirements applicable to specific type of ships	227
3.1	Bulk carriers	
3.2	Alternative requirements to those given in this Section	

4	Specific damage stability requirements for ships not subject to the SOLAS Convention	227
---	--	-----

- 4.1 Passenger ships
- 4.2 Non-propeller units with the service notation barge - accommodation

## **Section 12 Protective Coatings in Water Ballast Tanks (COAT-WBT)**

1	General	229
1.1	Application	
1.2	Definitions	
2	Coating selection and specification	231
2.1	General Principles	
2.2	Coating Technical File	
2.3	Health and safety	
2.4	Coating Standard	
2.5	Coating system approval	
2.6	Coating inspection requirements	
2.7	Verification requirements	
2.8	Alternative systems	
3	Survey activities	240
3.1	Review of the scheme for selection and application of coating system	
3.2	Plan review	
3.3	Type approval of shop primer	
3.4	Inspection and testing	
3.5	Surface preparation survey	
3.6	Coating application survey	
3.7	Final inspection after sea trials	

## **Section 13 Crew Accommodation and Recreational Facilities according to the Marine Labour Convention, 2006 (MLCDESIGN)**

1	General	242
1.1	Applications	
1.2	Documentation to be submitted for approval	
2	Design requirements	242
2.1	Basic Standard Requirements to obtain the additional class notation MLCDESIGN	

## **Section 14 Diving Support Ships (DIVINGSUPPORT)**

1	General	244
1.1	Applications	
1.2	Documents to be submitted	
1.3	Position keeping	
1.4	Stability criteria	
1.5	Hull structural arrangements related to the diving system	
1.6	Arrangement and installation of the diving system	
1.7	Electrical systems	

## **Section 15 High Voltage Shore Connection (HVSC-NB and HVSC)**

<b>1</b>	<b>General</b>	<b>247</b>
	1.1 Application	
	1.2 Definitions	
	1.3 Documents to be submitted	
<b>2</b>	<b>Requirements for both ship's and shore systems</b>	<b>247</b>
	2.1 General	
	2.2 Equipotential bonding	
	2.3 Compatibility	
	2.4 Failures	
	2.5 Location	
	2.6 Short-circuit calculation and electrical load analysis	
	2.7 Emergency shutdown and emergency stop	
<b>3</b>	<b>Ship requirements</b>	<b>249</b>
	3.1 Power connection from shore	
	3.2 Instrumentation and protection	
	3.3 System separation	
	3.4 Ship's power switchboard	
	3.5 Instrumentation	
	3.6 Protection	
	3.7 Shore connection circuit-breaker	
	3.8 Communication	
	3.9 HVSC behaviour in case of failure	
	3.10 Load transfer via blackout	
	3.11 Load transfer via temporary parallel operation	
<b>4</b>	<b>Ship to shore connection</b>	<b>251</b>
	4.1 Standardisation	
	4.2 Cable installation	
	4.3 Connectors	
	4.4 Cables	
	4.5 Protection	
	4.6 Data communication	
	4.7 Storage	
	4.8 Equipotential bond monitoring	
<b>5</b>	<b>Testing</b>	<b>252</b>
	5.1 Rule application	
	5.2 Type approved components	
	5.3 Component testing	
	5.4 Initial tests of shipside installation for HVSC-NB additional class notation	
	5.5 Ship Shore Integration tests for HVSC additional class notation	

## **Section 16 Helicopter Facilities (Helideck)**

<b>1</b>	<b>General</b>	<b>254</b>
	1.1 Application	
	1.2 Documents to be submitted	
<b>2</b>	<b>Helideck lay-out</b>	<b>255</b>
	2.1 General	
	2.2 Definitions	
	2.3 Landing area	

<b>3</b>	<b>Structural design and scantling</b>	<b>259</b>
	3.1 General and symbols	
	3.2 Design loads	
	3.3 Sea pressure	
	3.4 Landing load	
	3.5 Garage load	
	3.6 Forces due to ship accelerations and wind	
	3.7 Net scantling	
	3.8 Plating	
	3.9 Ordinary stiffeners	
	3.10 Primary supporting members	
<b>4</b>	<b>Specific requirements for the assignment of the Helideck-H notation</b>	<b>261</b>
	4.1 Refuelling and hangar facilities	
	4.2 Fire protection	
<b>5</b>	<b>Specific requirements for the assignment of the Helideck notation</b>	<b>263</b>
	5.1 Fire protection	
	5.2 Fire-fighting appliances and rescue equipment	
	5.3 Means of escape	

## **Section 17 Fire Protection (FIRE)**

<b>1</b>	<b>General</b>	<b>264</b>
	1.1 Application	
	1.2 Documents to be submitted	
<b>2</b>	<b>Requirements applicable to all spaces</b>	<b>265</b>
	2.1 General	
	2.2 Firefighter's Outfits	
	2.3 Manuals and instructions	
<b>3</b>	<b>Accommodation spaces</b>	<b>267</b>
	3.1 Restricted use of combustible materials	
	3.2 Structural fire protection	
	3.3 Means of escapes	
	3.4 Fire detection and alarm system	
	3.5 Portable fire extinguishers	
	3.6 Hydrants and fire hoses	
<b>4</b>	<b>Machinery spaces</b>	<b>268</b>
	4.1 Emergency escape and access	
	4.2 Ventilation	
	4.3 Fire control station	
	4.4 Hydrants and fire hoses	
	4.5 Precaution against oil ignition	
	4.6 Fire detection and alarm system	
	4.7 Monitoring system	
	4.8 Local application systems	
	4.9 Total flooding fire-extinguishing systems	
	4.10 Portable fire extinguishers	
<b>5</b>	<b>Special Provisions to prevent occurrence of a fire in machinery spaces</b>	<b>270</b>
	5.1 Portable fire extinguishers	
	5.2 Detection and identification of critical points	

5.3	Oil leakage prevention	
5.4	Oil leakage containment	
5.5	Prevention of ignition	
<b>6</b>	<b>Cargo decks and cargo spaces</b>	<b>272</b>
6.1	Introduction	
6.2	Oil and chemical tankers	
6.3	Gas carriers	
6.4	General cargo and bulk carriers	
6.5	Ro-ro ships	
6.6	Container ships	

## **Section 18 Carriage of Specific Solid Cargoes in Bulk**

<b>1</b>	<b>General</b>	<b>275</b>
1.1	Application	
1.2	Definitions	
1.3	Documents to be submitted	
<b>2</b>	<b>Class notation IMSBC-A</b>	<b>276</b>
2.1	General	
2.2	Specially constructed ships	
2.3	Ships specially fitted	
<b>3</b>	<b>Class notation IMSBC-nitrate</b>	<b>277</b>
3.1	General	
3.2	Fire protection	
3.3	Stability criteria	
3.4	Information to the Master	
<b>4</b>	<b>Class notation IMSBC-non cohesive</b>	<b>278</b>
4.1	General	
4.2	Stability criteria	
4.3	Information to the Master	
4.4	Hull strength	

## **Section 19 Ship Efficiency - Efficient Ship (S, DWT)**

<b>1</b>	<b>General</b>	<b>280</b>
1.1	Application	
1.2	Documents to be submitted	
<b>2</b>	<b>Reference conditions</b>	<b>280</b>
2.1	General	
<b>3</b>	<b>Ship's engine efficiency</b>	<b>281</b>
3.1	Main engine efficiency	
3.2	Auxiliary engine efficiency	
3.3	Calculation of the efficiency of the ship's engines	
<b>4</b>	<b>Consumption and working capability</b>	<b>282</b>
4.1	Ratio based on operative values	
4.2	Reference curves for specific ship types	

<b>5</b>	<b>Monitoring system</b>	<b>282</b>
	5.1 General	
	5.2 Measurements	
<b>6</b>	<b>Criteria for assignment</b>	<b>282</b>
	6.1 General	

## **Section 20 Navigation Surrounding the Arabian Peninsula (SAHARA)**

<b>1</b>	<b>General</b>	<b>283</b>
	1.1 Purpose and application	
	1.2 Required notations	
<b>2</b>	<b>Hull and Stability</b>	<b>283</b>
	2.1 Design Loads	
	2.2 Deck	
<b>3</b>	<b>Machinery</b>	<b>283</b>
	3.1 Cooling systems	
	3.2 Bearings	
	3.3 Boiler feed water and fresh water systems	
<b>4</b>	<b>COMFORT WITH REGARD TO CLIMATE</b>	<b>284</b>
	4.1 Design criteria	
	4.2 Ventilation	
	4.3 Calculations of heat gains and losses	
<b>5</b>	<b>Electrical installations</b>	<b>284</b>
	5.1 Ambient air and sea water temperatures	
	5.2 Humidity	
<b>6</b>	<b>Automation</b>	<b>285</b>
	6.1 Hardware type approval	

## **Section 21 Mooring (ANCHORING)**

<b>1</b>	<b>Application</b>	<b>286</b>
	1.1 General	
<b>2</b>	<b>Structure design principles</b>	<b>286</b>
	2.1 General	
	2.2 General	
<b>3</b>	<b>Design loads</b>	<b>287</b>
	3.1 General	
<b>4</b>	<b>Scantlings</b>	<b>287</b>
	4.1 General	
	4.2 Net scantlings	
<b>5</b>	<b>Protection against corrosion</b>	<b>287</b>
	5.1 General	

## **Section 22 Indoor Air Quality Monitoring (AIR MON)**

<b>1</b>	<b>General</b>	<b>288</b>
	1.1 Application	
	1.2 Basic principles	
<b>2</b>	<b>Definitions and acronym</b>	<b>288</b>
	2.1	
<b>3</b>	<b>Documentation to be submitted</b>	<b>288</b>
	3.1	
<b>4</b>	<b>Requirements</b>	<b>288</b>
	4.1 General	
	4.2 Operational requirements	
<b>5</b>	<b>Assignment criteria</b>	<b>289</b>
	5.1	

## **Section 23 Dedicated Oil Recovery System (DORS)**

<b>1</b>	<b>General</b>	<b>290</b>
	1.1 Application	
	1.2 Definition	
	1.3 Documents to be submitted	
<b>2</b>	<b>Requirements for the design and installation of the connectors</b>	<b>291</b>
	2.1 General	
	2.2 Arrangement	
	2.3 Design	
<b>3</b>	<b>Additional requirements for -NS notation</b>	<b>291</b>
	3.1 General	
	3.2 Requirements	

## **Section 24 LNG Ready (X1, X2, X3...) and CNG Ready (X1, X2, X3...)**

<b>1</b>	<b>General</b>	<b>293</b>
	1.1 Application	
<b>2</b>	<b>Assignment criteria</b>	<b>293</b>
	2.1	
<b>3</b>	<b>Documents to be submitted</b>	<b>294</b>
	3.1 Documentation requirements for characteristic "Design"	
	3.2 Documentation requirements for characteristics "Structure", "Tank", "Piping", "Users"	

## **Section 25 Dolphin Quiet Ship and Dolphin Transit Ship**

<b>1</b>	<b>General</b>	<b>296</b>
	1.1 Application	
	1.2 Terms and Definitions	
<b>2</b>	<b>Instrumentation, Measurements, Procedures, Reporting</b>	<b>297</b>
	2.1 General	
	2.2 Hydrophone and signal conditioning	
	2.3 Data acquisition, recording, processing and display	
	2.4 Distance measurement	
	2.5 Acoustic center	
<b>3</b>	<b>Measurement requirements and procedure</b>	<b>299</b>
	3.1 Introduction	
	3.2 Test site requirements	
	3.3 Sea surface conditions	
	3.4 Hydrophone deployment	
	3.5 Test course and ship operation	
	3.6 Sea Trails	
<b>4</b>	<b>Post processing</b>	<b>301</b>
	4.1 Introduction	
	4.2 Background noise adjustments	
	4.3 Sensitivity adjustments	
	4.4 Distance normalization	
	4.5 Hydrophone and run combination post processing	
<b>5</b>	<b>Reporting Example</b>	<b>303</b>
	5.1	
<b>6</b>	<b>Assignment criteria</b>	<b>303</b>
	6.1	
<b>7</b>	<b>Equivalence</b>	<b>303</b>
	7.1	

## **Section 26 Exhaust Gas Cleaning Systems (EGCS-SOX and EGCS-NOX)**

<b>1</b>	<b>General</b>	<b>304</b>
	1.1 Application	
	1.2 Basic principles	
<b>2</b>	<b>Definitions and acronym</b>	<b>304</b>
	2.1	
<b>3</b>	<b>Documentation to be submitted</b>	<b>304</b>
	3.1	
<b>4</b>	<b>Requirements</b>	<b>304</b>
	4.1 General	
<b>5</b>	<b>Assignment criteria</b>	<b>305</b>
	5.1 General	



## **Section 27 Man Overboard Detection System (MOB)**

<b>1</b>	<b>General</b>	<b>306</b>
	1.1 Application	
	1.2 Reference Rules and Standards	
<b>2</b>	<b>Definitions</b>	<b>306</b>
	2.1	
<b>3</b>	<b>Documentation to be submitted</b>	<b>306</b>
	3.1 Technical documentation	
	3.2 Company procedures	
<b>4</b>	<b>Design and requirements</b>	<b>307</b>
	4.1 General requirements	
	4.2 MOB detection zone	
	4.3 MOB event alarms and data	
	4.4 System log	
	4.5 Control, monitoring and safety	
	4.6 Control station	
	4.7 Event markers	
	4.8 Voyage Data Recorder	
<b>5</b>	<b>Personnel in charge of MOB</b>	<b>308</b>
	5.1 Qualification of personnel in charge of MOB	
	5.2 Company procedure	
<b>6</b>	<b>Initial survey</b>	<b>308</b>
	6.1 Testing devices	
	6.2 Environmental conditions	
	6.3 Information to be collected about the system	
	6.4 Information to be collected about the dropping test with manikin	
	6.5 Initial survey procedure	
	6.6 Probability of detection and false alarm	
<b>7</b>	<b>Test report</b>	<b>309</b>
	7.1	
<b>8</b>	<b>Certificate</b>	<b>309</b>
	8.1	

## **Section 28 Hybrid Propulsion Ship (HYB-...)**

<b>1</b>	<b>General</b>	<b>310</b>
	1.1 Application	
	1.2 Definitions	
	1.3 Additional Class Notation	
<b>2</b>	<b>Documentation to be submitted</b>	<b>310</b>
	2.1 General	
<b>3</b>	<b>Functional requirements</b>	<b>311</b>
	3.1 Application	
	3.2 Hybrid electric propulsion	
	3.3 Hybrid hydraulic propulsion	

4	Testing	311
4.1	Tests on board	

## Section 29 Cyber Resilience

1	General	312
1.1	Application	
1.2	Assignment criteria	
1.3	Maintenance, suspension and withdrawal of the notation	
1.4	Scope	
1.5	Reference regulations, guidelines, standards	
1.6	Definitions (See Note 1)	
1.7	Documents to be submitted	
2	Identification	314
2.1	Inventory	
3	Vulnerability assessment	315
3.1		
4	Threat assessment	316
4.1		
5	Risk assessment	316
5.1		
6	Protection safeguards	317
6.1	General	
6.2	Access control	
6.3	Network protection	
6.4	Data protection	
6.5	Awareness and training	
7	Detection safeguards	318
7.1	General	
7.2	Monitoring of normal operation	
7.3	Real-time detection of cyber events	
7.4	Offline auditing	
8	Response and recovery measures and procedures	319
8.1	General	
8.2	Response and recovery plan	
8.3	Training	
9	Test	319
9.1		
10	Maintenance	320
10.1		

## **Section 30 Digital Ship (ADC)**

<b>1</b>	<b>General</b>	<b>321</b>
	1.1 Application	
<b>2</b>	<b>Defintions</b>	<b>321</b>
	2.1	
<b>3</b>	<b>Documents to be submitted</b>	<b>321</b>
	3.1	
<b>4</b>	<b>Requirements</b>	<b>321</b>
	4.1 General	
	4.2 Data to be collected, recorded and transferred by the data collector	
	4.3 Minimum Data Acquisition Rate	
	4.4 Recorded Data (Representative Value and Time Stamp)	
	4.5 Storage Requirements	
	4.6 Interface	
<b>5</b>	<b>General</b>	<b>322</b>
	5.1 Application	

## **Section 31 Air Lubrication System (AIR LUB)**

<b>1</b>	<b>Scope and application</b>	<b>323</b>
	1.1	
<b>2</b>	<b>Documents to be submitted</b>	<b>323</b>
	2.1	
<b>3</b>	<b>Design requirements</b>	<b>323</b>
	3.1 Hull	
	3.2 Stability	
	3.3 Machinery	
<b>4</b>	<b>Installation requirements</b>	<b>324</b>
	4.1 Hull	
	4.2 Machinery	
<b>5</b>	<b>Equipment testing requirements</b>	<b>324</b>
	5.1 Machinery	
<b>6</b>	<b>Tests on board</b>	<b>325</b>
	6.1	

## **Section 32 Persons with reduced mobility (PMR-ITA)**

<b>1</b>	<b>General</b>	<b>326</b>
	1.1 Application	
	1.2 Assignment criteria	
	1.3 Scope	
	1.4 Reference regulations, guidelines, standards	
	1.5 Definitions	

1.6	Documents to be submitted	
<b>2</b>	<b>Requirements</b>	<b>327</b>
2.1	Ships built after 1 October 2004	
2.2	Ships built before 1 October 2004	

## **Section 33 BIOSAFE SHIP**

<b>1</b>	<b>General</b>	<b>328</b>
1.1	Application	
<b>2</b>	<b>Documents to be submitted</b>	<b>328</b>
2.1		
<b>3</b>	<b>Requirements</b>	<b>328</b>
3.1	General requirements	
3.2	Additional arrangements, systems and operative procedures	
3.3	Applicable requirements	
<b>4</b>	<b>BIOSAFE index</b>	<b>330</b>
4.1	Index calculation	
<b>5</b>	<b>Assignment criteria</b>	<b>331</b>
5.1	Cruise ships and ro-ro passenger ships with sleeping facilities for passenger	
5.2	Passenger ships and ro-ro passenger ships in short sea	
5.3	Cargo Ships	
<b>6</b>	<b>Novel features</b>	<b>331</b>
6.1	General	
<b>7</b>	<b>Systems and components</b>	<b>331</b>
7.1	Statements for systems and components contributing to the BIOSAFE Index	

## **Section 34 REMOTE**

<b>1</b>	<b>General</b>	<b>332</b>
1.1	Application	
1.2	Definitions	
<b>2</b>	<b>Requirements</b>	<b>332</b>
2.1	Devices for livestreaming	
2.2	Connectivity Kit	
2.3	Hazardous areas	
2.4	Training, qualification and certification of on-board personnel	
2.5	Electronic certificates	
<b>3</b>	<b>Assignment of the additional class notation</b>	<b>333</b>
3.1		

## **Section 35 NH3 Fuelled Ready (X1, X2, X3...)**

1	General	334
	1.1 Application	
2	Assignment criteria	334
	2.1	
3	Documents to be submitted	335
	3.1 Documentation requirements for characteristic "Design"	
	3.2 Documentation requirements for characteristics "Structure", "Tank", "Piping", "Users"	

## **Section 36 SUSTAINABLE SHIP**

1	General	337
	1.1 Application	
2	Definitions	337
	2.1	
3	Documents to be submitted	337
	3.1	
4	Sustainable index calculation	337
	4.1	
5	Assignment criteria	337
	5.1	

## **Section 37 Maritime Autonomous Surface Ships (MASS)**

1	General	339
	1.1 Application	
	1.2 Scope and assignment criteria	
	1.3 Documents to be submitted	

## **Section 38 H2 FUELLED READY (X1, X2, X3...)**

1	General	340
	1.1 Application	
2	Assignment criteria	340
	2.1	
3	Documents to be submitted	341
	3.1 Documentation requirements for characteristic "Design"	
	3.2 Documentation requirements for characteristics "Structure", "Tank", "Piping", "Users"	

## **Section 39 METHYL/ETHYL ALCOHOL FUELLED READY (X1, X2, X3...)**

<b>1</b>	<b>General</b>	<b>343</b>
1.1	Application	
<b>2</b>	<b>Assignment criteria</b>	<b>343</b>
2.1		
<b>3</b>	<b>Documents to be submitted</b>	<b>344</b>
3.1	Documentation requirements for characteristic "Design"	
3.2	Documentation requirements for characteristics "Structure", "Tank", "Piping", "Users"	

## **Section 40 Enhanced Maintenance (em)**

<b>1</b>	<b>General</b>	<b>346</b>
1.1	Application	
1.2	Conditions for the assignment and maintenance of the notation	
<b>2</b>	<b>Documentation to be submitted</b>	<b>346</b>
2.1	Plans and documents to be submitted for hull structures	
2.2	Hot spot map	
2.3	Inspection and Maintenance Plan (IMP)	
2.4	Plans and documents to be submitted for machinery	
<b>3</b>	<b>Inspection and Maintenance Plan (IMP)</b>	<b>347</b>
3.1	Minimum requirements	
3.2	General scope of IMP	
3.3	Periodicity of inspections	
3.4	Extent of inspections	
3.5	Changes to Inspection and Maintenance Plan	
<b>4</b>	<b>Acceptance criteria</b>	<b>350</b>
4.1	Coating assessment	
4.2	Sacrificial anode condition	
4.3	Thickness measurements	
4.4	Pitting	
4.5	Fractures	
<b>5</b>	<b>Machinery items</b>	<b>352</b>
5.1	Scope of IMP for machinery and systems	
5.2	Performances	
5.3	Manufacturer's recommendations	
<b>6</b>	<b>Maintenance of the notation</b>	<b>353</b>
6.1	Annual audit at the Owner's offices	
6.2	Annual EM survey	
6.3	Occasional EM survey	
6.4	Renewal EM survey	
6.5	Suspension and withdrawal of the notation	

## **Section 41 Cargo Piping Protected (CPP)**

<b>1</b>	<b>General</b>	<b>358</b>
	1.1 Application	
<b>2</b>	<b>Cargo Piping - Pollution Prevention Measures</b>	<b>358</b>
	2.1 Routing	
	2.2 Stripping and small diameter lines	
	2.3 Sea chests	
	2.4 Connection to ballast system	
	2.5 Crude oil washing system	
	2.6 Slop tanks	

## **Section 42 Coating Performance Standard in Cargo Oil Tanks (CPS-COT)**

<b>1</b>	<b>General</b>	<b>360</b>
	1.1 Application	
	1.2 Definitions	
<b>2</b>	<b>Coating selection and specification</b>	<b>360</b>
	2.1 General principles	
	2.2 Coating Technical File	
	2.3 Health and safety	
	2.4 Coating Standard	
	2.5 Coating system approval	
	2.6 Coating inspection requirements	
	2.7 Verification requirements	
	2.8 Alternative systems	
<b>3</b>	<b>Survey activities</b>	<b>365</b>
	3.1 General	

## **Section 43 Digital Ship (D)**

<b>1</b>	<b>General</b>	<b>366</b>
	1.1 Application	
<b>2</b>	<b>Definitions</b>	<b>366</b>
	2.1	
<b>3</b>	<b>Documents to be submitted</b>	<b>366</b>
	3.1	
<b>4</b>	<b>Requirements</b>	<b>366</b>
	4.1 General	
	4.2 Data stored (Data Signature and Time Stamp)	
	4.3 Redundancy	
	4.4 Data shared with the Society	

## **Section 44 Fuel Sampling**

<b>1</b>	<b>General</b>	<b>369</b>
	1.1 Application	
<b>2</b>	<b>Requirements</b>	<b>369</b>
	2.1 General	
	2.2 Location of sampling points	

## **Section 45 Wind Assisted Propulsion System (WAPS)**

<b>1</b>	<b>General</b>	<b>370</b>
	1.1 Scope and application	
	1.2 Documentation to be submitted	
	1.3 Risk assessment	
<b>2</b>	<b>Design requirements</b>	<b>372</b>
	2.1 Structure and outfitting	
	2.2 Stability	
	2.3 Machinery	
	2.4 Electrical installations	
	2.5 Control, Monitoring, Alarm and Safety Systems	
<b>3</b>	<b>Operation and maintenance</b>	<b>376</b>
	3.1 Operating and Maintenance Manual	
	3.2 Rig Booklet	
	3.3 Access Arrangement	
<b>4</b>	<b>Equipment testing requirements</b>	<b>377</b>
	4.1 Machinery	
<b>5</b>	<b>Tests on board</b>	<b>377</b>
	5.1 General	
	5.2 Pre-sea trials tests	
	5.3 Sea trials	

## **Section 46 Ultra Low Emission Vessel (ULEV)**

<b>1</b>	<b>General</b>	<b>378</b>
	1.1 Application	
<b>2</b>	<b>Definitions and Symbols</b>	<b>378</b>
	2.1 Definitions	
	2.2 Symbols	
<b>3</b>	<b>Documents to be submitted</b>	<b>379</b>
	3.1 Documents to be submitted for each engine	
	3.2 Documents to be submitted for the ship	
<b>4</b>	<b>Requirements</b>	<b>380</b>
	4.1 Engine testing	
	4.2 Emission threshold values	
	4.3 Emission control diagnostic	



	4.4	ULEV mode	
<b>5</b>		<b>Emission measurement</b>	<b>381</b>
	5.1	Pollutants	
	5.2	Measurements	
	5.3	Fuel specifications	
	5.4	Deterioration factors	
	5.5	Control areas	
<b>6</b>		<b>Surveys</b>	<b>383</b>
	6.1	Initial Survey	

## **Appendix 1 Test Procedures for Coating Qualification for Water Ballast Tanks of All Types of Ships and Double-side Skin Spaces of Bulk Carriers**

<b>1</b>		<b>Scope</b>	<b>384</b>
	1.1		
<b>2</b>		<b>Definitions</b>	<b>384</b>
	2.1		
<b>3</b>		<b>Testing</b>	<b>384</b>
	3.1		
<b>4</b>		<b>Test on simulated ballast tank conditions</b>	<b>384</b>
	4.1	Test condition	
	4.2	Test results	
	4.3	Acceptance criteria	
	4.4	Test report	
<b>5</b>		<b>Condensation chamber test</b>	<b>387</b>
	5.1	Test condition	
	5.2	Test results	
	5.3	Acceptance criteria	
	5.4	Test report	

## **Appendix 2 Mooring Loads**

<b>1</b>		<b>General</b>	<b>389</b>
	1.1	Application	
<b>2</b>		<b>Required documentation</b>	<b>389</b>
	2.1	Unit and mooring data	
	2.2	Presentation of the results	
<b>3</b>		<b>Analysis methods</b>	<b>389</b>
	3.1	Mooring analysis	
<b>4</b>		<b>Loads</b>	<b>390</b>
	4.1	General	
	4.2	Static loads	
	4.3	Wind Loads	
	4.4	Current loads	
	4.5	Wave loads	

5	Environmental conditions	390
	5.1	
6	Results and maximum expected value	390
	6.1	

### **Appendix 3 Additional Systems, Components and Operative Procedures to Evaluate the Biosafe Index as per the BIOSAFE Notation**

1	Ship's General Arrangement	392
	1.1 Allocation of a dedicated area for the containment of a possible infection outbreak	
	1.2 Dressing and undressing areas	
	1.3 Routes for medical care and containment areas	
	1.4 Dedicated area onboard for health monitoring centre	
	1.5 Routes for social distancing	
	1.6 Routes for provision, luggage, spare parts management	
	1.7 Working places	
	1.8 Corridors, stairs and lifts	
2	Cabins and rooms	393
	2.1 Cabins with enhanced sanitation capability surfaces	
	2.2 Rooms with fixed oxygen distribution	
	2.3 Rooms with direct alarm to medical care	
	2.4 Information videos	
3	Public spaces	393
	3.1 Touch free/hands free solutions for means of access	
	3.2 Touch free/hands free solutions for public toilets	
	3.3 Surfaces with high utilization rate designed for easy sanitation	
	3.4 Surfaces with high utilization rate active materials or coatings	
	3.5 Public space design	
	3.6 Onboard payments and contactless devices	
	3.7 Information videos	
4	Prevention of contamination by surface	394
	4.1 UV-C lamps for surface disinfection	
	4.2 Fixed or portable sanitation system	
	4.3 Store for sanitation and disinfection products	
	4.4 Fixed sanitation system of dirty routes	
5	Prevention of contamination by air	394
	5.1 HVAC system for containment area - independent system	
	5.2 HVAC system for containment area - separated system	
	5.3 HVAC system for containment area - under pressure isolation	
	5.4 HVAC system - air disinfection by means UV-C lamp	
	5.5 HVAC system - air disinfection by chemical agents	
	5.6 HVAC system - air disinfection by filters	
	5.7 Cabins - changes per hour	
	5.8 Public spaces - changes per hour	
	5.9 Cabins HVAC outlet	
6	Prevention of contamination by fresh water system	395
	6.1 FW disinfection by means UV-C lamp	

	6.2	FW disinfection by means chemical agents	
<b>7</b>		<b>Prevention of contamination by grey water and sewage system</b>	<b>395</b>
	7.1	Grey water disinfection	
	7.2	Sewage disinfection	
<b>8</b>		<b>Garbage Handling</b>	<b>395</b>
	8.1	Medical waste dedicated bins	
	8.2	Contaminated waste management	
<b>9</b>		<b>Enhanced medical care</b>	<b>396</b>
	9.1	Intensive care unit	
	9.2	Ventilators	
	9.3	Totally enclosed stretcher	
	9.4	Gastight coverall	
<b>10</b>		<b>Monitoring systems</b>	<b>396</b>
	10.1	People tracking system for social distancing monitoring	
	10.2	Infected persons tracking system	
	10.3	Gates for the automatic detection of potential affected people	
	10.4	Containment areas monitoring	
	10.5	Equipment for distributed mustering	
	10.6	Behaviour monitoring	

#### **Appendix 4 Test Procedures for Coating Qualification for Cargo Oil Tanks of Crude Oil Tankers**

<b>1</b>		<b>Scope</b>	<b>397</b>
	1.1		
<b>2</b>		<b>Definitions</b>	<b>397</b>
	2.1		
<b>3</b>		<b>Testing</b>	<b>397</b>
	3.1		
<b>4</b>		<b>Test gas composition</b>	<b>397</b>
	4.1		
	4.2	Test liquid	
<b>5</b>		<b>Gas-tight cabinet test</b>	<b>398</b>
	5.1	Test condition	
	5.2	Test results	
	5.3	Acceptance criteria	
	5.4	Test report	
<b>6</b>		<b>Immersion test</b>	<b>399</b>
	6.1		
	6.2	Test results	
	6.3	Acceptance criteria	
	6.4	Test report	
<b>7</b>		<b>Precautions regarding the use of dangerous materials</b>	<b>400</b>
	7.1		



## REFRIGERATING INSTALLATIONS (REEFER)

---

- SECTION 1      GENERAL REQUIREMENTS**
- SECTION 2      ADDITIONAL REQUIREMENTS FOR THE NOTATION REF-CARGO**
- SECTION 3      ADDITIONAL REQUIREMENTS FOR THE NOTATION REF-CONT**
- SECTION 4      ADDITIONAL REQUIREMENTS FOR THE NOTATION REF-STORE**



# SECTION 1

# GENERAL REQUIREMENTS

## 1 General

### 1.1 Application

**1.1.1** The following additional class notations are assigned, in accordance with Pt A, Ch 1, Sec 2, [6.9], to ships with refrigerating installations complying with the applicable requirement of this Chapter:

- **REF-CARGO** for installations related to carriage of cargo
- **REF-CONT** for installations related to carriage of containers
- **REF-STORE** for installations related to preservation of ship's domestic supplies

**1.1.2** The requirements of this Chapter apply to refrigerating installations on ships, and include the fixed plants for refrigerating holds of cargo ships, fishing and factory ships, fruit and juice carrier ships, etc., refrigerated containers, various ship's services, such as air conditioning, galleys, etc. These requirements are specific to permanently installed refrigerating installations and associated arrangements and are to be considered additional to those specified in Pt C, Ch 1, Sec 13, which are mandatory for all ships with refrigerating installations.

**1.1.3** The notations given in [1.1.1] may be completed by the following:

- **AIRCONT** for ships fitted with a controlled atmosphere plant on board
- **PRECOOLING** for refrigerating plants designed for ensuring within a suitable time interval the cooling down of a complete cargo of fruit or vegetables to the required temperature of transportation
- **QUICKFREEZE** for refrigerating plants of fishing vessels and fish factory ships where the design and equipment of such plants have been recognised as suitable to permit quick-freezing of fish in specified conditions.

However, in general, these notations may be only granted to ships with the notation **REF-CARGO**.

### 1.2 Temperature conditions

#### 1.2.1 Cargo space conditions

The minimum internal temperature or the temperature range for which the notation is granted is to be mentioned in the notation. For design temperatures to be considered for designing the plant, see [2.1.1] and [2.1.2].

This indication is to be completed by the mention of any operational restriction such as maximum sea water temperature, geographical or seasonal limitations, etc., as applicable.

#### 1.2.2 Container conditions

For refrigerating plants on board container ships complying with the provisions of Sec 3, in addition to the data listed in [1.2.1], the notation is to specify the maximum number of containers liable to be served, and the value of their heat transfer coefficient

$k$  : in  $W/(m^2 \cdot ^\circ C)$

or

$U$  :  $k S$ , in  $W/^\circ C$ ,

where  $S$  is the surface through which the heat is transferred, in  $m^2$ , as determined by type tests.

### 1.3 Definitions

#### 1.3.1 Direct cooling system

Direct cooling system is the system by which the refrigeration is obtained by direct expansion of the refrigerant in coils fitted on the walls and ceilings of the refrigerated chambers.

#### 1.3.2 Indirect cooling system

Indirect cooling system is the system by which the refrigeration is obtained by brine or other secondary refrigerant, which is refrigerated by a primary refrigerant, circulated through pipe grids or coils fitted on the walls and ceilings of the refrigerated chambers.

#### 1.3.3 Air cooling system

Direct air cooling system is the system by which the refrigeration is obtained by circulation of air refrigerated by an air cooler.

#### 1.3.4 Refrigerant

Refrigerant is a cooling medium which is used to transmit and maintain the cool in the refrigerated chamber.

#### 1.3.5 Brine

Brine is a refrigerant constituted by a solution of industrial salts, which is normally used to cool the chambers in the indirect cooling systems, as secondary refrigerant. In general, in this Chapter, the word brine is also used to cover other types of secondary refrigerants, as for instance refrigerants based on glycol.

#### 1.3.6 Refrigerating unit

A refrigerating unit includes one or more compressors driven by one or more prime movers, one condenser and all the associated ancillary equipment necessary to form an independent gas-liquid system capable of cooling refrigerated chambers.

When the installation includes a secondary refrigerant (brine), the refrigerating unit is also to include a brine cooler (evaporator) and a pump.

### 1.3.7 Refrigerated chamber

A chamber is any space which is refrigerated by a refrigerating unit. A chamber may be a cargo space or any other ship service space, such as for instance the galley.

## 2 Design criteria

### 2.1 Reference conditions

#### 2.1.1 Design temperature

Unless otherwise indicated in the specification, refrigerating plants are to be designed for the following design temperatures:

- Frozen cargo: minus 20°C
- Fish: minus 20°C
- Fruit: 0°C
- Bananas: 12°C.

#### 2.1.2 Environmental conditions

Unless otherwise indicated in the ship specification, the following environmental conditions are to be considered for the heat transfer and balance calculations and for the running rate of the refrigerating machinery:

- Sea water temperature: 32°C
- Outside air temperature: 35°C
- Relative humidity of air at 35°C: 80%.

For the determination of heat transfer through outside walls liable to be exposed to sun radiation, the outside air temperature is to be taken as equal to 45°C.

#### 2.1.3 Operating conditions

The refrigerating plant inclusive of all machinery, equipment and accessories is to operate satisfactorily under the conditions indicated in Tab 1.

## 3 Documentation

### 3.1 Refrigerating installations

#### 3.1.1 Plans to be submitted

The plans listed in Tab 2 are to be submitted as applicable.

The listed plans are to be constructional plans complete with all dimensions and are to contain full indication of types of materials employed.

Plans of equipment which are type approved by the Society need not be submitted, provided the types and model numbers are made available.

#### 3.1.2 Calculations to be submitted

The calculations listed in Tab 3 are to be carried out in accordance with criteria agreed with the Society and are to be submitted.

### 3.2 Controlled atmosphere installations

3.2.1 The plans listed in Tab 4 are to be submitted.

## 4 General technical requirements

### 4.1 Refrigerating unit availability

#### 4.1.1 (1/7/2009)

The refrigerating installation is to include two or more refrigerating units, as defined in [1.3.6].

The refrigerating capacity of the installed units is to be sufficient to maintain the design temperatures defined in [2.1.1] in the refrigerated spaces under the environmental conditions defined in [2.1.2], with any one of the refrigerating units out of action (that having the greatest capacity, if the units are not equal) and the other(s) working 24 hours a day.

### 4.2 Refrigeration of chambers

#### 4.2.1 Refrigerating systems

Refrigeration of the chambers may be achieved by one of the following systems:

- direct cooling system
- indirect cooling system
- air cooling system.

#### 4.2.2 Cold distribution

- a) The chambers may be refrigerated either by means of grids distributed on their walls or by means of air circulation on air coolers.
- b) Grids and/or air coolers may be supplied either by brine or by a direct expansion system depending on the type of refrigerating system.

### 4.3 Defrosting

#### 4.3.1 Availability

- a) Means are to be provided for defrosting air cooler coils, even when the refrigerated chambers are loaded to their maximum. Air coolers are to be fitted with trays and gutters for gathering condensed water.
- b) The defrosting system is to be designed so that defrosting remains possible even in the case of failure of an essential component such as a compressor, a circulation pump, a brine heater or a heating resistance.

#### 4.3.2 Draining

Arrangements are to be made to drain away the condensate even when the refrigerated chambers are loaded to their maximum. See [5.8] for specific requirements.



**Table 1 : Operating conditions**

Length of ship (m)		< 100	< 200	≤ 300	> 300
Permanent list		15°	15°	15°	15°
Roll		± 22,5°	± 22,5°	± 22,5°	± 22,5°
Pitch		± 10°	± 7,5°	± 5°	± 3°
Trim	Aft	5°	2,5°	1,5°	1°
	Forward	2°	1°	0,5°	0,3°

**Table 2 : Documents to be submitted**

No.	A/I (1)	Document
1	I	Detailed specification of the plant (refrigerating machinery and insulation) including the reference design and ambient conditions
2	I	General arrangement of refrigerated spaces including: <ul style="list-style-type: none"> <li>the intended purpose of spaces adjacent to refrigerated spaces</li> <li>the arrangement of air ducts passing through refrigerated spaces</li> <li>the arrangement of steelwork located in refrigerated spaces or in insulated walls</li> <li>the arrangement of the draining system</li> <li>the individual volume and the total volume of the refrigerated spaces</li> </ul>
3	A	Drawings showing the thickness and methods of fastening of insulation on all surfaces in refrigerated spaces, including: <ul style="list-style-type: none"> <li>insulation material specification</li> <li>hatch covers</li> <li>doors</li> <li>steel framing (pillars, girders, deck beams)</li> <li>bulkhead penetrations</li> <li>etc.</li> </ul>
4	A	Cooling appliances in refrigerated spaces (coil grids, air coolers with air ducts and fans, etc.)
5	I	Characteristic curves of fans (capacity, pressure, power consumption)
6	A	Distribution of the thermometers and description of remote thermometer installation, if any, including: <ul style="list-style-type: none"> <li>detailed description of the apparatus with indication of the method and instruments adopted, measuring range, degree of accuracy and data regarding the influence of temperature variations on connection cables</li> <li>electrical diagram of apparatus, with indication of power sources installed, characteristics of connection cables and all data concerning circuit resistance</li> <li>drawings of sensing elements and their protective coverings and indicators, with specification of type of connections used</li> </ul>
7	A	General arrangement and functional drawings of piping (refrigerant system, brine system if any, sea water system, defrosting system, etc.)
8	I	Characteristic curves of circulating pumps for refrigerant or brine (capacity, pressure, power consumption, etc.)
9	I	General arrangement of refrigerating machinery spaces (main data regarding prime movers for compressors and pumps, including source of power, are to be included in this drawing)
10	A	Electrical wiring diagram
11	A	Compressor main drawings (sections and crankshaft or rotors) with characteristic curves giving the refrigerating capacity
12	A	Drawings of main items of refrigerant system and pressure vessels, such as condensers, receivers, oil separators, evaporators, gas containers, etc.
13	A	Remote control, monitoring and alarm system (if any)
14	A	Air refreshing and heating arrangement for fruit cargo
15	I	Number of insulated cargo containers to be individually cooled by the shipboard plant and their heat transfer rates
16	I	Operation manual for the refrigerating plant and for refrigerated containers, as applicable
(1)	A	: to be submitted for approval in four copies
	I	: to be submitted for information in duplicate

**Table 3 : Calculations to be submitted (1/7/2002)**

No.	(1)	Item
1	I	Detailed calculation of the heat balance of the plant. The calculation is to take into account the minimum internal temperatures for which the classification is requested and the most unfavourable foreseen ambient conditions.
2	I	Duct air flow calculations
(1) I : to be submitted for information in duplicate		

#### 4.4 Prime movers and sources of power

##### 4.4.1 Number of power sources

- The motive power for each refrigerating unit is to be provided by at least two distinct sources. Each source is to be capable of ensuring the service of the plant under the conditions stated in [2.1.1], [2.1.2] and [2.1.3], without interfering with other essential services of the ship. For small plants, see also [4.8].
- Where the refrigerating units are driven by internal combustion engines, one power source for each refrigerating unit may be accepted.

**Table 4 : Documents to be submitted**

No.	A/I (1)	Item
1	I	Description of the installation
2	I	Location of spaces covered and gas-tight subdivisions
3	I	Design overpressure
4	A	Details and arrangement of inert gas generating equipment
5	A	Piping diagrams, including installation details
6	A	Ventilation and gas-freeing system
7	A	Instrumentation and automation plans
8	I	Instruction manual
9	I	Cargo space sealing arrangement
(1) A : to be submitted for approval in four copies I : to be submitted for information in duplicate		

##### 4.4.2 Electric motors

Where the prime movers of refrigerating units are electric motors, the electrical power is to be provided by at least two distinct generating sets.

##### 4.4.3 Steam prime movers

Where steam prime movers are used in refrigerating units they are to be connected to at least two different boilers.

Furthermore, the exhaust steam is to be led to the main and auxiliary condensers.

#### 4.5 Pumps

##### 4.5.1 Minimum number of condenser pumps

- At least one standby condenser circulating pump is to be provided; this pump is to be ready for use and its capacity is not to be less than that of the largest pump that it may be necessary to replace.
- One of the condenser circulating pumps may be one of the ship's auxiliary pumps, provided its capacity is sufficient to serve the refrigerating plant working at maximum power without interfering with essential services of the ship.

##### 4.5.2 Plants with intermediate cooling media

- Where an intermediate cooling medium is used, at least one standby brine circulating pump is to be provided; this pump is to be ready for use and its capacity is not to be less than that of the largest pump that it may be necessary to replace.
- The same provision applies to any other type of plants in which the circulation of refrigerant is ensured by pumps.

#### 4.6 Sea connections

##### 4.6.1 Number and location of sea connections

- The cooling water is normally to be taken from the sea by means of at least two separate sea connections.
- The sea connections for the refrigerating plant are to be distributed, as far as practicable, on both sides of the ship.

##### 4.6.2 Connections to other plants

Where the circulating pump(s) of the refrigerating plant is/are connected to the same circuit as other pumps, precautions are to be taken in the design and arrangement of piping so that the working of one pump does not interfere with another.

##### 4.6.3 Dry dock conditions

In order to keep the refrigerating plant running when the ship is in dry dock, means are to be provided to supply cooling water either from a tank or from a shore connection.

#### 4.7 Refrigerating machinery spaces

##### 4.7.1 Arrangement

Refrigerating machinery spaces are to be provided with efficient means of ventilation and drainage and, unless otherwise allowed by the Society, are to be separated from the refrigerated spaces by means of gas-tight bulkheads.

Ample space is to be provided around the refrigerating machinery to permit easy access for routine maintenance and to facilitate overhauls, particularly in the case of condensers and evaporators.

##### 4.7.2 Dangerous refrigerants in machinery spaces

Use of dangerous refrigerants in machinery spaces may be permitted in accordance with Pt C, Ch 1, Sec 13, [2.2.3].

## 4.8 Exemptions for small plants

**4.8.1** Consideration may be given to waiving the requirements in [4.4.1], [4.4.2] and [4.4.3] above on power source duplication for refrigerating plants serving spaces having a volume below 400 m<sup>3</sup>.

## 4.9 Personnel safety

**4.9.1** Means are to be provided to monitor the presence of personnel in refrigerated cargo spaces and to promptly detect any possible need for help from outside the space.

# 5 Refrigerated chambers

## 5.1 Construction of refrigerated chambers

### 5.1.1 Bulkheads surrounding refrigerated chambers

- a) Generally, the bulkheads of refrigerated chambers are to be of metallic construction; however, the bulkheads between two refrigerated spaces intended to contain cargoes of the same nature or having no contaminating effect need not be metallic.
- b) The bulkheads are to be gas-tight.
- c) Steels intended to be used for the construction of refrigerated chambers are to comply with the applicable provisions of Pt B, Ch 4, Sec 1 for low temperature steels.

### 5.1.2 Closing devices

- a) The closing devices of the accesses to refrigerated chambers, such as doors, hatch covers and plugs for loading or surveying are to be as far as possible gas-tight.
- b) The ventilators of refrigerated chambers, if any, are to be fitted with gas-tight closing devices.

## 5.2 Penetrations

### 5.2.1 Penetration of pipes and ducts

Penetrations of pipes through watertight, gas-tight or fire-resistant decks and bulkheads are to be achieved by fitting glands suitable for maintaining the tightness and fire-resisting characteristics of the pierced structures.

### 5.2.2 Penetration of electrical cables

Where electrical wiring passes through refrigerated chambers, the relevant requirements of Part C, Chapter 2 are to be complied with.

## 5.3 Access to refrigerated spaces

### 5.3.1 Doors and hatches

- a) Refrigerated chambers are to be provided with emergency escape ways enabling the evacuation of stretcher-borne personnel. The escape ways are to be provided with emergency lights.
- b) Access doors and hatches to refrigerated chambers are to be provided with means of opening from inside even where they have been shut from outside.

### 5.3.2 Manholes

Manholes on the tank top of refrigerated chambers are to be surrounded by an oil-tight steel coaming of at least 100 mm height.

## 5.4 Insulation of refrigerated chambers

### 5.4.1

- a) The insulating material is to be non-hygroscopic. The insulating boards are to have satisfactory mechanical strength. Insulating materials and binders, if any, are to be odourless and so selected as not to absorb any of the odours of the goods contained in refrigerated chambers. The materials used for linings are to comply with the same provisions.
- b) Polyurethane and other plastic foams used for insulation are to be of a self-extinguishing type according to a standard acceptable by the Society. In general, these foams are not to be used without a suitable protective coating.
- c) The insulation together with its coating is normally to have low flame spread properties according to an accepted standard.
- d) Plastic foams of a self-extinguishing type, suitably lined, may also be used for insulation of piping and air ducts.
- e) When it is proposed to use foam prepared in situ, the detail of the process is to be submitted for examination before the beginning of the work.

## 5.5 Characteristics of insulation

### 5.5.1 Protection of insulation

The insulation and the lining are to be carefully protected from all damage likely to be caused by the goods contained in the chamber or by their handling.

### 5.5.2 Insulation strength

The insulation lining and the air screens with their supports are to be of sufficient strength to withstand the loads due to the goods liable to be carried in the refrigerated chambers.

### 5.5.3 Removable panels

- a) A sufficient number of removable panels are to be provided in the insulation, where necessary, to allow inspection of the bilges, bilge suction, bases of pillars, vent and sounding pipes of tanks, tops of shaft tunnels and other structures and arrangements covered by the insulation.
- b) Where the insulation is covered with a protective lining, certain panels of this lining are to be provided with a suitable number of inspection openings fitted with watertight means of closing.

## 5.6 Miscellaneous requirements

### 5.6.1 Refrigerated chambers adjacent to oil or fuel tanks

- a) An air space of at least 50 mm is to be provided between the top of fuel and lubricating oil tanks and the insulation, so designed as to allow leaks to drain to the bilges. Such air space may be omitted provided multiple

sheaths of an odourless oil-resisting material are applied to the upper surface of tank tops. The total required thickness of sheathing depends on the tank construction, on the composition used and on the method of application.

- b) In general, the sides of fuel and lubricating oil tanks are to be separated from refrigerated spaces by means of cofferdams. The cofferdams are to be vented, the air vents fitted for this purpose are to be led to the open and their outlets are to be fitted with wire gauze which is easily removable for cleaning or renewal. The cofferdams may be omitted provided that multiple sheaths of an odourless oil-resisting material are applied on the tank side surface facing the refrigerated chambers. The total required thickness of this sheathing depends on the composition used and on the method of application.

### 5.6.2 Refrigerated chambers adjacent to high temperature spaces

The insulation of the walls adjacent to coalbunkers or to any space where an excessive temperature may arise, by accident or otherwise, is to be made of mineral wool or any equivalent material; wood chips, if any, are to be fireproof and separated from the plates on which they are fitted by means of insulating sheets.

### 5.6.3 Wooden structures

Wooden beams and stiffeners are to be insulated and strips of suitable insulating material are to be fitted between them and the metallic structures.

### 5.6.4 Metal fittings

All metal fittings (bolts, nuts, hooks, hangers, etc.) necessary for fitting of the insulation are to be galvanised or made in a corrosion-resistant material.

### 5.6.5 Equipment below the insulation

Arrangements are to be made whilst building in order to facilitate the examination in service of parts such as bilge suctions, scuppers, air and sounding pipes and electrical wiring which are within or hidden by the insulation.

## 5.7 Installation of the insulation

### 5.7.1

- a) Before laying the insulation, steel surfaces are to be suitably cleaned and covered with a protective coating of appropriate composition and thickness.
- b) The thickness of the insulation on all surfaces together with the laying process are to be in accordance with the approved drawings.
- c) The insulating materials are to be carefully and permanently installed; where they are of slab form, the joints are to be as tight as possible and the unavoidable crevices between slabs are to be filled with insulating material. Bitumen is not to be used for this purpose.
- d) Joints of multiple layer insulations are to be staggered.
- e) In applying the insulation to the metallic structures, any paths of heat leakage are to be carefully avoided.

## 5.8 Drainage of refrigerated spaces

### 5.8.1 General

All refrigerated cargo spaces and trays under air coolers are to be fitted with means suitable for their continuous and efficient drainage.

### 5.8.2 Drain pipes

- a) Drain pipes from refrigerating space cooler trays are to be fitted with liquid sealed traps provided with non-return valves which are easily accessible, even when the chamber is fully loaded.
- b) Threaded plugs, blank flanges and similar means of closing of drain pipes from refrigerated spaces and trays of air coolers are not permitted.
- c) Where means of closing of drain pipes are required by the Owner, these are to be easily checked and the controls are to be located in an accessible position on a deck above the full load waterline.

### 5.8.3 Drain tanks

- a) Where the draining from cargo spaces is led to a closed drain tank, the size of the tank is to be such as to be able to collect all the waters produced during defrosting operations.
- b) Drain tanks are to be provided with appropriate venting and sounding arrangements.
- c) When two or more refrigerated spaces are connected to the same drain tank, the common lines are to be fitted with check valves to prevent the possibility of passage of water from one refrigerated space to another.

### 5.8.4 Scuppers

- a) Scuppers from the lower holds and from trays of air coolers installed on the inner bottom are to be fitted with liquid seals and non-return devices.
- b) Scuppers from 'tweendeck refrigerated spaces and from trays of air coolers installed above the inner bottom are to be fitted with liquid seals, but not necessarily with non-return devices.
- c) Where scuppers from more than one refrigerated space or tray are led to a common header or common tank, in addition to the liquid seal on each pipe, a sufficient number of non-return devices are to be provided, so arranged as to prevent lower compartments from being flooded by drains from higher compartments.
- d) Water seals are to be of sufficient height and readily accessible for maintenance and filling with anti-freezing liquid.
- e) Valves, scuppers and drain pipes from other non-refrigerated compartments are not to be led to the bilges of refrigerated spaces.

## 6 Refrigerants

### 6.1 General

#### 6.1.1 Refrigerants used in direct refrigerating systems

Some commonly employed refrigerants considered acceptable for use with primary (direct expansion) systems are listed in Tab 5.

**Table 5 : Refrigerants for use in direct refrigerating systems**

Refrigerant Number	Refrigerant commercial name	Chemical Formula
R12	Dichlorodifluoromethane	C Cl <sub>2</sub> F <sub>2</sub>
R21	Dichlorofluoromethane	C H Cl <sub>2</sub> F
R22	Chlorodifluoromethane	C H Cl F <sub>2</sub>
R113	Trichlorotrifluoroethane	CCl <sub>2</sub> FCClF <sub>2</sub>
R114	Dichlorotetrafluoroethane	CClF <sub>2</sub> CClF <sub>2</sub>
R134a	Tetrafluoroethane	CH <sub>2</sub> FCF <sub>3</sub>
R500	Refrigerant 12/152a 73.8/26.2 mass%	C Cl <sub>2</sub> F <sub>2</sub> / C H <sub>3</sub> C H F <sub>2</sub>
R502	Refrigerant 12/115 48.8/51.2 mass%	C H Cl F <sub>2</sub> / C Cl F <sub>2</sub> C F <sub>3</sub>

**Table 6 : Refrigerants for use in indirect refrigerating systems**

Refrigerant Number	Refrigerant commercial name	Chemical Formula
R717	Ammonia	NH <sub>3</sub>
R744	Carbon dioxide	CO <sub>2</sub>

#### 6.1.3 Other permissible refrigerants

The use of refrigerants other than those listed in Tab 5 and Tab 6 may be authorised by the Society on a case-by-case basis, provided that the physical properties and chemical analysis are clearly stated and the appropriate safety measures are foreseen in the installation design.

#### 6.1.4 Prohibited refrigerants

For restrictions on the selection of refrigerants, see Pt C, Ch 1, Sec 13, [2.2.1] and Pt C, Ch 1, Sec 13, [2.2.2].

#### 6.1.5 Use of ammonia as refrigerant

For specific requirements relative to the use of ammonia as refrigerant, see Pt C, Ch 1, Sec 13, [2.3].

### 6.2 Rated working pressures

#### 6.2.1 Pressure parts design pressure

- The refrigerant design pressure is not to be less than the maximum working pressure of the installation or its parts, either in operation or at rest, whichever is the greater. No safety valve is to be set at a pressure higher than the maximum working pressure.
- In general, the design pressure of the low pressure side of the system is to be at least the saturated vapour pres-

#### 6.1.2 Refrigerants used in indirect refrigerating systems

The refrigerants listed in Tab 6 may be used solely in indirect system refrigeration plants.

sure of the refrigerants at 40°C. Due regard is to be paid to the defrosting arrangement which may increase the pressure on the low pressure system.

- The design pressure of the high pressure side of the installation is to be based on the condenser working pressure while it operates with water cooling in tropical zones. In general, the rated working pressure is to be taken not less than the effective saturated vapour pressure at 50°C.

#### 6.2.2 Refrigerants listed in Tables 5 and 6

In general, the design pressure for high and low pressure parts of systems using refrigerants listed in Tab 5 and Tab 6 is to be taken not less than the values indicated in Tab 7.

**Table 7**

Refrigerant number	Design working pressure, in MPa	
	High pressure side	Low pressure side
R12	1,6	1,0
R21	0,3	0,2
R22	2,2	1,3
R113	0,2	0,2
R114	0,4	0,4
R134a	1,3	1,1
R500	2,0	1,2
R502	2,3	1,6
R717	2,2	1,5
R744	1,1	0,7

## 7 Refrigerating machinery and equipment

### 7.1 General requirements for prime movers

#### 7.1.1

- a) The diesel engines driving the compressors are to satisfy the relevant requirements of Pt C, Ch 2, Sec 2.
- b) The electric motors driving the compressors, pumps or fans are to satisfy the relevant requirements of Pt C, Ch 2, Sec 4.

### 7.2 Common requirements for compressors

#### 7.2.1 Casings

The casings of rotary compressors are to be designed for the design pressure of the high pressure side of the system indicated in Tab 7.

#### 7.2.2 Cooling

- a) Air-cooled compressors are to be designed for an air temperature of 45°C.
- b) For sea water cooling, a minimum inlet temperature of 32°C is to be applied. Unless provided with a free outlet, the cooling water spaces are to be protected against excessive overpressure by safety valves or rupture safety devices.

#### 7.2.3 Safety devices

- a) Stop valves are to be provided on the compressor suction and discharge sides.
- b) A safety valve or rupture disc is to be arranged between the compressor and the delivery stop valve.
- c) When the power exceeds 10 kW, the protection may consist of a pressure control device which automatically stops the machine in the event of overpressure. Details of the design of this device are to be submitted to the Society.
- d) Compressors arranged in parallel are to be provided with check valves in the discharge line of each compressor.
- e) Means are to be provided to indicate the correct direction of rotation.

### 7.3 Reciprocating compressors

#### 7.3.1 Crankcase

- a) When subjected to refrigerant pressure, compressor crankcases are to be either:
  - designed to withstand the rated working pressure of the LP side; or
  - fitted with safety valves designed to lift at a pressure not exceeding 0,8 times the crankcase test pressure;

in this case, arrangements are to be made for the refrigerant to discharge to a safe place; or

- protected against overpressures by means of devices likely to ensure a similar protection.
- b) An oil level sight glass is to be fitted in the crankcase.
  - c) Means are to be provided to heat the crankcase when the compressor is stopped.

#### 7.3.2 Hydraulic lock

Reciprocating compressors having cylinder bores of 50 mm and above are to be provided with means to relieve high pressure due to hydraulic lock. Alternatively means to prevent the possibility of refrigerants entering the cylinders may be considered.

### 7.4 Screw compressor bearings

**7.4.1** Whenever the bearing surfaces are locally hardened, details of the process are to be submitted to the Society. In any case, the process is to be limited to the bearing area and is not to be extended to the fillets.

### 7.5 Pressure vessels

#### 7.5.1 General

The general requirements of Pt C, Ch 1, Sec 13, [2.1.2] are applicable.

#### 7.5.2 Refrigerant receivers

- a) The receivers are to have sufficient capacity to accumulate liquid refrigerant during changes in working conditions, maintenance and repairing.
- b) Each receiver is to be fitted with suitable level indicators. Glass gauges, if any, are to be of the flat plate type and are to be heat resistant. All level indicators are to be provided with shut-off devices.
- c) Each receiver that may be isolated from the system is to be provided with an adequate overpressure safety device.

#### 7.5.3 Evaporators and condensers

- a) All parts of evaporators and condensers are to be accessible for routine maintenance; where deemed necessary, efficient means of corrosion control are to be provided.
- b) When condensers and evaporators of the "coil-in-casing" type cannot be readily dismantled owing to their dimensions, a suitable number of inspection openings not smaller than 230 mm x150 mm are to be provided on their shells.
- c) Safety valves are to be fitted on the shells of evaporators and condensers when the pressure from any connected pump may exceed their anticipated working pressure.

#### 7.5.4 Brine tanks

- a) Brine tanks which can be shut off are to be protected against excessive pressure due to thermal expansion of the brine by safety valves or by an interlocking device blocking the shut-off valves in open position.
- b) In general, brine tanks are not to be galvanised at their side in contact with brine. Where they are galvanised

and are of a closed type, they are to be provided with a suitable vent arrangement led to the open for toxic gases. The vents are to be fitted with easily removable wire gauze diaphragms and their outlets are to be located in positions where no hazard for the personnel may arise from the gases. Where brine tanks are not of a closed type, the compartments in which they are located are to be provided with efficient ventilation arrangements.

#### 7.5.5 Air coolers (15/7/2015)

- a) Where finned-tube or multi-plate type air coolers are used, the distance between the fins or plates, in general, is not to be less than 10 mm, at least on the air inlet side. For the purpose of this requirement, the air inlet side means 1/4 of the length of the cooler measured in the direction of the air flow.
- b) Air coolers are to be made of corrosion-resistant material or protected against corrosion by galvanising.
- c) Air coolers are to be provided with drip trays and adequate drains.

#### 7.5.6 Insulation

Pressure vessels are to be thermally insulated to minimise the condensation of moisture from the ambient atmosphere. The insulation is to be provided with an efficient vapour barrier and is to be protected from mechanical damage.

### 7.6 General requirements for piping

#### 7.6.1 General

The general requirements of Pt C, Ch 1, Sec 13, [2.1.3] are applicable.

#### 7.6.2 Piping arrangement

- a) Pipelines are to be adequately supported and secured so as to prevent vibrations. Approved type flexible hoses may be used where necessary to prevent vibrations.
- b) Provision is to be made for allowing thermal expansion and contraction of the piping system under all operating conditions. Approved type flexible hoses may be used where necessary for this purpose.
- c) Pipe insulation is to be protected from mechanical damage and is to be provided with an efficient vapour barrier which is not to be interrupted in way of supports, valves, fittings, etc.

### 7.7 Accessories

#### 7.7.1 Oil separators

Oil separators with drains are to be fitted on the refrigerant lines. When a wire gauze is fitted, this is to be of material which cannot be corroded by the refrigerant.

#### 7.7.2 Filters

- a) Efficient filters are to be fitted at the suction of compressors and on the high pressure side of reducing valves. The filters of compressors may be incorporated in the crankcases, provided their filtering area is sufficient.
- b) Filters are to be fitted with a wire gauze strainer which cannot be corroded by the refrigerant and allowing a

sufficient flow area for the fluid. Small filters such as those of reducing valves are to be such that they can be easily removed without any disassembling of the pipes.

#### 7.7.3 Dehydrators

An efficient dehydrator is to be fitted on systems using refrigerant types R12, R21, R22 or R502. The dehydrator is to be so designed and arranged that the drying product can be replaced without any disassembling of the pipes.

### 7.8 Refrigerating plant overpressure protection

#### 7.8.1 General

- a) The refrigerant circuits and associated pressure vessels are to be protected against overpressure by safety valves, rupture discs or equivalent arrangement. However, inadvertent discharge of refrigerant to the atmosphere is to be prevented.
- b) The safety devices are to be in such number and so located that there is no possibility that any part of the system may be isolated from a safety device. Where it is necessary to be able to isolate one of these devices from the system for maintenance purposes, the devices may be duplicated provided a change-over valve is arranged in such a way that when one device is isolated it is not possible to shut off the other.
- c) Pressure vessels connected by pieces of pipe without valves may be considered as a single pressure vessel from the point of view of overpressure protection, provided that the interconnecting pipe does not prevent effective venting of the vessels.

#### 7.8.2 Safety valves

- a) Safety valve discharges are to be led to a safe place above the deck. Discharge pipes are to be designed in such a way that the ingress of water, snow, dirt or debris affecting the operation of the system can be prevented. In the case of the refrigerant R717 (ammonia), the discharge pipe outlet is to be as high as possible on the ship.
- b) Refrigerant pumps are to be fitted with safety valves at the discharge side. The valves may discharge at the pump suction side or at another suitable location.
- c) After setting, safety valves are to be suitably protected against the possibility of inadvertent change of setting.
- d) Safety valves are to lift at a pressure not more than 0,80 times the test pressure of the parts concerned.

## 8 Specific requirements for direct and indirect refrigerating systems

### 8.1 Specific requirements for refrigerating systems

#### 8.1.1 Direct expansion system

- a) Refrigerating systems where the refrigerant expands directly in the coils within the refrigerated chambers may be considered by the Society only for application in

chambers of small capacity and at the specific request of the Owner.

- b) For the acceptance of such a system by the Society, special consideration is to be given to the following:
- the proposed refrigerant
  - the use of coil pipes having butts welded circumferentially within refrigerated chambers, to prevent leakages of gas within the chambers themselves
  - the effective protection of chamber cooling coils within the chambers from shocks and external mechanical damage.
- c) Coils within each refrigerated space are to be arranged in at least two sections, and the number of sections in each refrigerated space is to be clearly indicated on the plan to be submitted for approval. Each section is to be fitted with valves or cocks so that it can be shut off.

### 8.1.2 Brine systems

- a) Each brine pump is to be connected to the brine tanks and to the valve manifolds controlling the brine pipes. Each brine pipe is to be fitted with a stop valve on the delivery, and a regulating valve is to be fitted on the return pipe.
- b) All regulating valves are to be located in positions accessible at any time.
- c) Brine pipes are not to be galvanised on the inside.
- d) The thickness of the brine pipes is to be not less than 2,5 mm; in the case of pipes with threaded joints, the thickness at the bottom of the thread is not to be less than the above value.
- e) Steel pipe cooling coils and their associated fittings are to be externally protected against corrosion by galvanising or other equivalent method.
- f) For brine tanks, see [7.5.4].
- g) For brine coils in refrigerated spaces, see Sec 2, [1.2].

## 8.2 Specific requirements for air cooling systems and distribution and renewal of air in cargo spaces

### 8.2.1 Rated circulation

The air circulation system is to be so designed as to ensure as uniform as possible a distribution of air in refrigerated spaces.

### 8.2.2 Refrigerated air circulation systems

- a) For air coolers, see [7.5.5].
- b) Air coolers are to be designed for a maximum temperature difference between cooling medium and cooling

air at the air cooler inlet of about 5°C for fruit cargoes and about 10°C for deep frozen cargoes.

- c) Air coolers may be operated either by brine circulation or by direct expansion of the refrigerant.
- d) The coils are to be divided into two sections, each capable of being easily shut off (see Sec 2, [1.2.1]).
- e) Means for defrosting the coils of the air coolers are to be provided. Defrosting by means of spraying with water is to be avoided.
- f) Provision is to be made for heating the drains. In automated plants, the heating equipment is to be controlled by the defrosting program.
- g) Fans and their motors are to be arranged so as to allow easy access for inspection and repair and/or removal of the fans and motors themselves when the chambers are loaded with refrigerated cargo. Where duplicate fans and motors are fitted and each fan is capable of supplying the quantity of air required, it is sufficient that easy access for inspection is provided.
- h) The air circulation is to be such that delivery and suction of air from all parts of the refrigerated chambers are ensured.
- i) The air capacity and the power of the fans are to be in proportion to the total heat to be extracted from the refrigerated chambers, due regard being given to the nature of the service.
- j) When excess cooling capacity is required in order to cool or freeze all or part of the cargo from the ambient temperature to the minimum anticipated temperature, the air capacity is to be in proportion to the increased heat to be extracted, in accordance with the specifications approved by the Owner.

### 8.2.3 Air refreshing

- a) When refrigerated cargoes include goods which, under certain conditions, emit gases, odours or humidity, an efficient system is to be provided for air refreshing in the space concerned. Air inlets and outlets in such systems are to be provided with closing devices.
- b) The position of air inlets is to be such as to reduce to a minimum the possibility of contaminated air entering the refrigerated spaces.

## 9 Instrumentation, alarm, monitoring

### 9.1 General

#### 9.1.1 Automation safety equipment

The automation safety equipment is to be of the fail-safe type and is to be so designed and installed as to permit manual operation. In particular, manual operation of the compressors is to be ensured in the event that any of the equipment is inoperable.

#### 9.1.2 Regulation devices

Regulation devices such as motor-operated valves or thermostatic expansion valves are to be such that they can be isolated, thus allowing the plant to be manually operated should the need arise.



## 9.2 Instrumentation, alarm and monitoring arrangement

### 9.2.1 Compressors

Tab 8 summarises the minimum control and monitoring requirements for refrigerating compressors.

**Table 8 : Refrigerating compressors**

Item	Indicator	Function			Comments
			Alarm	Automatic shutdown	
Refrigerant suction	pressure	low		X	At saturated temperature and including intermediate stages
Refrigerant discharge	pressure	high		X	
Refrigerant suction	temp.				For installations over 25 kW only
Refrigerant discharge	temp.				
Lubricating oil	pressure	low		X	
Lubricating oil	temp.				For installations over 25 kW only
Cooling water	temp.				For installations over 25 kW only
Cumulative running hours	hours				All screw compressors and installations over 25 kW only

**Note 1:** Shut-off is also to activate an audible and visual alarm.

**Table 9 : Refrigerating systems**

Item	Indicator	Function			Comments
			Alarm	Automatic shutdown	
Air in refrigerated space	temperature	high	X		
Air fan		failure	X		
Chamber temperature	temperature		X		
Secondary refrigerant suction	pressure	low		X	
Secondary refrigerant discharge	pressure	high		X	
Lubricating oil	pressure	low		X	
Bilge level in refrigerated space		high	X		

**Note 1:** Shut-off is also to activate an audible and visual alarm.

## 10 Material tests, inspection and testing, certification

### 10.1 General

#### 10.1.1 (1/7/2015)

The provision of this paragraph applies to the equipment forming part of the refrigerating installations. Alternative testing procedures may be accepted by the Society based on Testing specification agreed among interested parties.

### 10.2 Material testing

**10.2.1** The materials for the construction of the parts listed below are to be tested in compliance with the requirements of Part D of the Rules:

- compressor crankshafts, couplings, connecting rods and piston rods
- compressor liners, cylinder heads and other parts subjected to pressure
- steel and copper tubing for evaporator and condenser coils and for pressure piping in general
- oil separators, intermediate receivers and other pressure vessels included in the gas circuit
- condensers and evaporators of shell type (tube or welded plate).

### 10.3 Shop tests

#### 10.3.1 Individual pieces of equipment

Shop tests are to be carried out on pumps, fans, electric motors and internal combustion engines forming parts of

refrigerating installations, following procedures in accordance with the requirements applicable to each type of machinery. The relevant running data (capacity, pressure head, power and rotational speed, etc.) are to be recorded for each item.

**10.3.2 Refrigerating unit**

- a) At least one refrigerating unit of each type installed on board is to be subjected to shop tests in order to ascertain its refrigerating capacity in the most unfavourable temperature conditions expected, or in other temperature conditions established by the Society.
- b) Where the complete unit cannot be shop tested (for instance, in the case of direct expansion installations), only the compressors are to be tested according to procedures approved by the Society.

**10.4 Pressure tests at the workshop**

**10.4.1 Strength and leak tests**

Upon completion, all parts included in the suction and delivery branches of the refrigerant circuit are to be subjected to a strength and leak test.

The strength test is a hydraulic test carried out with water or other suitable liquid. The leak test is a test carried out with air or other suitable gas while the component is submerged in water at a temperature of approximately 30°C.

The components to be tested and the test pressure are indicated in Tab 10.

**Table 10**

Component	Test pressure	
	Strength test	Leak test
Compressor cylinder blocks, cylinder covers, stop valves, pipes and other components (condensers, receivers, etc.) of the high pressure part of the circuit.	1,5 p <sub>1</sub>	p <sub>1</sub>
Compressor crankcases subjected to refrigerant pressure, stop valves, pipes and other components of the low pressure part of the circuit.	1,5 p <sub>2</sub>	p <sub>2</sub>
Where p <sub>1</sub> and p <sub>2</sub> are the design pressures indicated in [6.2] for high pressure and low pressure parts.		

**10.4.2 Condensers**

Circulating water sides of condensers are to be subjected to a hydrostatic test at a pressure equal to 1,5 times the design pressure, but in no case less than 0,1 MPa.

**10.4.3 Brine system**

- a) Brine coils of air coolers are to be subjected to a hydrostatic test at a pressure equal to 1,5 times the design pressure, but in no case less than 0,7 MPa.
- b) Cast iron casings for brine evaporators are to be subjected to a hydrostatic test at a pressure equal to 1,5

times the design pressure, but in no case less than 0,1 MPa.

- c) Steel casings for brine evaporators fitted on the suction side of the pumps are to be subjected to a hydrostatic test at a pressure not less than 0,2 MPa.
- d) Steel casings for brine evaporators fitted on the delivery side of the pumps are to be subjected to a hydrostatic test at a pressure equal to 1,5 times the design pressure, but in no case less than 0,35 MPa.
- e) Open brine tanks are to be tested by filling them completely with water.

**10.5 Thermometers and manometers**

**10.5.1**

- a) All thermometers recording the temperature of refrigerated spaces, the air temperature at the inlet and outlet of air coolers and the temperature at various points in the refrigerant circuit or in the brine circuit are to be carefully calibrated by the Manufacturer. The Society reserves the right to require random checks of the calibration.
- b) The accuracy of manometers and other measuring instruments is also to be checked before the commencement of the tests required in [10.6].

**10.6 Shipboard tests**

**10.6.1 Pressure tests**

After installation on board, and before operating, the plant is to be subjected to a test at the maximum working pressure determined as indicated in [6.2.1].

However, all pressure piping portions which have welded joints made on board are to be subjected to a strength test at a pressure equal to 1,5 times the rated working pressure before being insulated.

**10.6.2 Tests of the ventilation system**

- a) After installation, the ventilation system is to be tested and the pressure, air capacity in cubic metres per minute, maximum rotational speed and power absorbed by the fans are to be recorded.
- b) The distribution of air in the various refrigerated spaces is to be checked.

**10.6.3 Operational tests**

- a) Upon completion of the installation, each refrigerating plant is to be subjected to an operational test on board in order to check the proper operation of the machinery and the refrigerating capacity of the plant by means of a heat balance test.
- b) Before starting the actual test, the Surveyor will check at random that thermometers, pressure gauges and other instruments are in working order, calibrated and arranged as directed in each case by the Society.
- c) All the refrigerating machinery is to be put into service and all chambers, closed and empty, are to be simultaneously cooled to the minimum expected temperature, i.e. the temperature required to be entered in the notation, or a lower temperature determined so that a differ-

ence of at least 20°C can be maintained between the average external temperature and the temperature in the refrigerated spaces. The expected temperature is to be maintained for a period of time sufficient to remove all the heat from the insulation.

- d) Following this, the heat balance test may be commenced. The duration of the test may be 6 hours or, where necessary, even longer. Air cooler fans are to run at their normal output throughout the test.
- e) The regulation of the refrigerating capacity of the plant may be effected by reducing the number of running compressors, by varying their rotational speed or even by running them intermittently.
- f) Means of control where the load in the cylinders is varied or the gas is returned from the delivery side to the suction side are not permitted.
- g) The following data are to be recorded in the course of the test:
  - Temperatures in the refrigerated spaces, external air temperature and sea water temperature (in particular, at the outlet and inlet of the condensers). The external surfaces  $S$  of the walls corresponding to the temperature differences  $\Delta T$  measured between the inside and outside of the refrigerated spaces are to be detailed as well as the products  $S\Delta T$ .
  - Absorbed power and speed of the compressors and the temperatures and pressures which determine the running of the refrigerating machinery. The recorded data, through comparison with the thermodynamic cycle considered for the preparation of the cold production curves of the compressors, are to enable the corrections (superheating, undercooling) necessary for determination of the actual refrigerating capacity  $F$ .
  - Absorbed power of the motors driving the fans  $F_V$  and brine pumps  $F_P$

- The overall heat transfer coefficient  $k$  for the extreme climatic conditions considered may be obtained by the following formula:

$$F = k\Sigma(S \cdot \Delta T) + F_V + F_P + F_C$$

where  $F_C$  is a correcting term (normally small) which is to be introduced for other heat exchanges between the tested plant and the environment.

- h) Temperatures and pressures at various locations along the refrigerant and brine circuits.
  - i) Air temperatures at the inlet and outlet of air coolers.
  - j) In the course of the heat balance test, the above data is to be recorded at one-hour intervals. Prior to this test, the data may be recorded at 4-hour intervals, except for the external air and sea water temperatures, which are to be recorded at one-hour intervals at least for the last twelve hours of the test.
  - k) Special cases, e.g. when the test is carried out with very low external atmospheric temperatures which would require the temperature within the refrigerated cargo spaces to be brought down below the above specified values, or where the compressors are driven by constant speed prime movers, or where refrigerating plants of banana and fruit carriers are tested in winter time, or the minimum temperature required for classification is not the same for all the spaces will be specially considered by the Society.

## 10.7 Defrosting system

**10.7.1** The defrosting arrangements are also to be subjected to an operational test.

Instructions regarding the procedure to be followed for the operational test of the refrigerating plant on board will be given by the Society in each case.

## SECTION 2

# ADDITIONAL REQUIREMENTS FOR THE NOTATION REF-CARGO

### 1 General

#### 1.1 Application

**1.1.1** The requirements of this Section are applicable for the assignment of the additional class notation **REF-CARGO**. They are additional to the applicable requirements of Sec 1.

**1.1.2** These requirements are applicable independently of the number of refrigerated holds. Where only certain holds are fitted with a refrigerating plant for which the notation is requested, the number and the location of these holds will be indicated in an annex to the Certificate of Classification.

#### 1.2 Refrigeration of cargo spaces

**1.2.1** Cooling appliances, including brine coils, if any, are to be divided into two distinct systems capable of working separately in each refrigerated space; each of them is to be able to keep the cargo in a satisfactory cold condition. Each section is to be fitted with valves or cocks or similar devices so that it can be shut off.

**1.2.2** Consideration may be given to waiving the requirements in [1.2.1] on cooling system duplication for refrigerating plants serving spaces having volume below 200 m<sup>3</sup>.

#### 1.3 Heating

**1.3.1** Where it is intended to carry cargoes which may be adversely affected by low temperatures during cold seasons or in certain geographical areas, efficient means are to be provided for heating the spaces concerned.

### 2 Steels for hull structure

#### 2.1 Grades of steel

##### 2.1.1 (1/10/2014)

In addition to the requirements specified in Pt B, Ch 4, Sec 1, [2.4], apply the material grade as specified in Tab 1 to the hull structure steels of ships with ice strengthening.

**Table 1 : Minimum Material Grades for ships with ice strengthening (1/10/2014)**

Structural member category	Material grade
Shell strakes in way of ice strengthening area for plates	Grade B/AH

### 3 Refrigerated cargo spaces

#### 3.1 Insulation

##### 3.1.1 Protection of insulation

In addition to the requirement in Sec 1, [5.5.1], the floors of refrigerated spaces to about 600 mm beyond the projection of the hatchway outline are to be covered with a hard wood sheathing about 50 mm thick, or with a protection of similar efficiency.

##### 3.1.2 Insulation strength

In addition to the requirement in Sec 1, [5.5.2], where insulations are to support fork-lift trucks, they are to be submitted to a strength test performed on a sample in conditions representative of the service conditions.

##### 3.1.3 Cargo battens

- Cargo battens of 50x50 mm, spaced at approximately 400 mm, are to be fitted to the vertical boundaries of refrigerated cargo spaces.
- Floors of refrigerated cargo spaces are to be similarly fitted with battens of 75x75 mm spaced at approximately 400 mm; over the insulation of the top of shaft tunnels, cargo battens are to be of hard wood.
- The arrangement of the cargo battens is to be such that free circulation of air is not impaired and cargo cannot come in contact with the insulation or with the brine coils, if any.
- Battens on the floors of refrigerated spaces may be omitted in the case of hanging cargoes.

### 4 Instrumentation

#### 4.1 Thermometers in cargo spaces

##### 4.1.1 Number of thermometers

- Each refrigerated space with a volume not exceeding 400 m<sup>3</sup> is to be fitted with at least 4 thermometers or temperature sensors. Where the volume exceeds 400 m<sup>3</sup>, this number is to be increased by one for each additional 400 m<sup>3</sup>.
- Sensors for remote electric thermometers are to be connected to the instruments so that, in the event of failure of any one instrument, the temperature in any space can still be checked through half the number of sensors in this space.

##### 4.1.2 Direct reading thermometers

The tubes intended to contain thermometers are to have a diameter not less than 50 mm and are to be carefully isolated from the ship's structure. If they pass through spaces

other than those they serve, they are to be insulated when passing through those spaces. Joints and covers of such tubes are to be insulated from the plating to which they are attached and installed on open decks so that water will not collect and freeze in them when measuring temperatures.

#### 4.1.3 Electric thermometer apparatus for remote reading

The apparatus is to provide the temperature indications with the accuracy required in [4.1.5] in conditions of vibrations and inclinations expected on board and for all ambient temperatures, up to 50°C, to which indicating instruments and connection cables may be exposed.

#### 4.1.4 Distant electric thermometer sensors

- a) Sensing elements are to be placed in refrigerated spaces where they are not liable to be exposed to damage during loading and unloading operations and well clear of heat sources such as, for instance, electric lamps, etc.
- b) Sensing elements in air coolers are to be placed at a distance of at least 900 mm from coils or fan motors.
- c) When arranged in ducts, they are to be placed at the centre of the air duct section, as far as possible.
- d) Sensing elements are to be protected by a corrosion-resistant impervious covering. Conductors are to be permanently secured to sensing elements and to indicating instruments and connected accessories. Plug-and-socket connections are allowed only if they are of a type deemed suitable by the Society.
- e) All sensing elements are to be easily accessible.

#### 4.1.5 Accuracy

- a) Direct reading thermometers are to permit reading with an accuracy of 0,1°C for temperatures between 0°C and 15°C. Temperatures given by remote reading are to have an accuracy of:
  - $\pm 0,3^\circ\text{C}$  (at 0°C) for the carriage of fruit and vegetables, and
  - $\pm 0,5^\circ\text{C}$  (at 0°C) for the carriage of frozen products.
- b) The instrumental error, to be ascertained by means of calibration by comparison with a master-thermometer with officially certified calibration, is not to exceed the following values:
  - $\pm 0,15^\circ\text{C}$ , in the range  $-3^\circ\text{C}$  to  $+3^\circ\text{C}$
  - $\pm 0,25^\circ\text{C}$ , in all other ranges of the scale.
- c) In general, the scale range is to be within  $-30^\circ\text{C}$  and  $+20^\circ\text{C}$ ; in any case it is to be  $\pm 5^\circ\text{C}$  greater than the range of application of the instrument.
- d) In the graduated scale, the space corresponding to 1°C is not to be less than 5 mm.

#### 4.1.6 Data-logger

- a) When a data-logger is installed, at least one sensing element for each refrigerated space, both in the space itself and in its air circulating system, is to be connected to another independent indicating instrument, approved by the Society. The data-logger is to register to 0,1 °C. Indicating instruments are to be fed by two independent power sources. If they are fed by the network on board through a transformer and rectifier unit, a spare unit is

also to be provided and is to be easily replaceable aboard. If they are fed by storage batteries, it will be sufficient to arrange easily changeable batteries.

- b) A prototype apparatus is to be checked and tested by a Surveyors at an independent recognised laboratory, or at the Manufacturer's facilities, to verify by means of suitable tests that the degree of accuracy corresponds to the above provisions.
- c) The capacity of the apparatus to withstand stipulated vibrations, impacts and temperature variations and its non-liability to alterations due to the salt mist atmosphere, typical of conditions on board, are to be verified.

## 5 Additional requirements for AIR-CONT notation

### 5.1 General

#### 5.1.1 Applicability

- a) The following requirements apply to ships with permanently installed equipment capable of generating and controlling an oxygen poor atmosphere in cargo holds in order to slow down the ripening process of fruit or other cargo, for which the notation **AIRCONT** is requested.
- b) The following requirements are additional to those of Sec 1.
- c) The **AIRCONT** notation will be not granted to ships using portable apparatus for the generation of the controlled atmosphere or to ships with permanently installed apparatus serving less than 50% of the allowable cargo space.

#### 5.1.2 Operational performance

- a) Normally, the displacement of the oxygen from the spaces which are intended to operate under controlled atmosphere is obtained by an inert gas. The most commonly used inert gases are:
  - carbon dioxide (CO<sub>2</sub>)
  - nitrogen (N<sub>2</sub>)
- b) The oxygen content in air controlled spaces is to be maintained between 10% and 2% of the volume, with an accuracy of at least 0,2%.
- c) Where carbon dioxide is used for controlling the atmosphere, the plant is to be capable of controlling and maintaining a concentration of CO<sub>2</sub> in all or in any of the controlled spaces between 10% and 0,2% in volume. The selected CO<sub>2</sub> content is to be maintained with an accuracy of at least 0,2%.
- d) Where nitrogen (N<sub>2</sub>) is used to control the atmosphere, the generating plant is to be capable of supplying at least:
  - 0,05 m<sup>3</sup>/h of nitrogen with 4% oxygen content for each cubic meter of the total cargo space which is intended for controlled atmosphere, at normal operating temperature
  - 0,025 m<sup>3</sup>/h of nitrogen with 2% oxygen content for each cubic meter of the total cargo space which is

intended for controlled atmosphere, at normal operating temperature

- For different oxygen content, intermediate values may be interpolated.

### 5.1.3 Operating and safety manual

An operating and safety manual covering at least the items listed below is to be provided on board:

- principal information on the use of controlled atmosphere
- complete description of the controlled atmosphere installation on board
- hazards of low oxygen atmospheres and consequential effects on human life
- countermeasures when exposed to low oxygen atmospheres
- instructions for operation, maintenance and calibration of all gas detectors
- instructions for use of portable oxygen analysers with alarm for personal protection
- prohibition of entry to spaces under controlled atmospheres
- loading instructions prior to injection of gas
- procedure for checking security of controlled atmosphere zones, doors and access hatches prior to injection of gas
- gas-freeing procedure for all controlled atmosphere zones
- procedure for checking atmosphere of controlled atmosphere zones before entry.

## 5.2 Controlled atmosphere cargo spaces and adjacent spaces

### 5.2.1 Air-tightness of controlled atmosphere

- a) The controlled atmosphere zones are to be made air-tight. Particular attention is to be paid to sealing of hatches, plugs and access doors in each controlled atmosphere zone. Double seals are to be fitted to each opening.
- b) Openings for pipes, ducts, cables, sensors, sampling lines and other fittings passing through the decks and bulkheads are to be suitably sealed and made air-tight.
- c) The liquid sealed traps from bilges and drains from the cooler trays are to be deep enough, when filled with liquid which will not evaporate or freeze, to withstand the design pressure in each controlled atmosphere zone taking account of the ship motion.
- d) Air refreshing inlets and outlets are to be provided with isolating arrangements.

### 5.2.2 Controlled atmosphere zone protection

- a) Means are to be provided to protect controlled atmosphere zones against the effect of overpressure or vacuum.
- b) One pressure/vacuum valve is to be fitted in each controlled atmosphere zone, set for the design conditions of the zone.
- c) The proposed pressure/vacuum valves for the various zones are to be of adequate size to release any excess pressure when the gas generating unit is delivering at its maximum capacity to a single cargo space or compartment and to relieve the vacuum at maximum cooling rate.
- d) Pressure/vacuum valve discharges are to be located at least 2 m above the open deck and 10 m away from any ventilation inlets and openings to accommodation spaces, service spaces, machinery spaces and other similar manned spaces. Discharge piping is to be arranged to preclude ingress of water, dirt or debris which may cause the equipment to malfunction.
- e) Arrangements for the protection of cargo spaces or compartments against over or under pressure other than those referred to above will be the subject of special consideration.

### 5.2.3 Gas freeing

- a) The arrangements for gas freeing of controlled atmosphere zones are to be capable of purging all parts of the zone to ensure a safe atmosphere.
- b) Cargo air cooling fans and the air refreshing arrangements may be used for gas freeing operations.
- c) Gas freeing outlets are to be led to a safe place in the atmosphere 2 m above the open deck and 10 m away from air inlets and openings to accommodation spaces, service spaces, machinery spaces and similar manned spaces.

### 5.2.4 Ventilation of adjacent zones

- a) Deckhouses and other adjacent spaces, or other spaces containing gas piping where gas leakage may create an oxygen deficient atmosphere, which need to be entered regularly, are to be fitted with a positive pressure type mechanical ventilation system with a capacity of at least 10 air changes per hour capable of being controlled from outside these spaces.
- b) Adjacent spaces not normally entered are to be provided with a mechanical ventilation system which can be permanent or portable to free the gas space prior to entry. Where portable ventilators are used, at least two units capable of ensuring at least 2 air changes per hour in the largest of such spaces are to be kept on board.
- c) Ventilation inlets are to be arranged so as to avoid recycling any gas.
- d) For container carriers with containers under controlled atmosphere which have arrangements to vent low oxygen air from each container under controlled atmosphere into the cargo space, venting arrangements are to be in accordance with the applicable requirements of these Rules.

## 5.3 Gas systems

### 5.3.1 General requirements

- a) Means are to be provided to reach and maintain the required oxygen and/or carbon dioxide levels in the controlled atmosphere zones. This may be accomplished by use of stored gas, portable or fixed gas generating equipment or other equivalent arrangements.
- b) The gas system is to have sufficient capacity to compensate for any gas loss from the controlled atmosphere zones and to maintain a positive pressure in all such zones.
- c) Gas systems utilising compressors are to be provided with two or more compressors and prime movers which together are capable of delivering the rated capacity. Each compressor is to be sized so that, with one compressor out of operation, the system is able to maintain the O<sub>2</sub> content in all designated cargo spaces within the specified range. Alternatively, one compressor and prime mover may be accepted if the compressor is capable of delivering the rated capacity and provided that spares for the compressor and prime mover are carried to enable any failure of the compressor and prime mover to be rectified on board.
- d) Air inlets are to be located such as to ensure that contaminated air is not drawn into the compressors.
- e) Where it is intended to supply gas by means of stored gas bottles, the arrangements are to be such that depleted bottles may be readily and safely disconnected and charged bottles readily connected.

### 5.3.2 Carbon dioxide generation

Carbon dioxide generating equipment is the subject of special consideration by the Society.

### 5.3.3 Passive type nitrogen generation

Passive type nitrogen generators such as gas separators and absorption units need not be duplicated.

### 5.3.4 Gas supply

- a) Gas systems are to be designed so that the pressure which they can exert on any controlled atmosphere zone will not exceed the design pressure of the zone.
- b) During initial operation, arrangements are to be made to vent the gas outlets from each generator to the atmosphere. All vents from gas generators are to be led to a safe location on the open deck.
- c) Where gas generators use positive displacement compressors, a pressure relief device is to be provided to prevent excess pressure being developed on the discharge side of the compressor.
- d) Suitable arrangements are to be provided to enable the supply mains to be connected to an external supply

- e) Where nitrogen (N<sub>2</sub>) is used:
  - means of controlling inadvertent release of nitrogen into controlled atmosphere zones, such as lockable non-return valves, are to be provided
  - the nitrogen delivery line is to be fitted with a safety valve capable of discharging the maximum nitrogen delivery
  - filters are to be fitted in the delivery line
  - oxygen and nitrogen exhaust lines are to be led to discharge in safe locations on open deck.

### 5.3.5 Segregation

- a) Fixed gas generating equipment, gas bottles or portable gas generators are to be located in a compartment reserved solely for their use. Such compartments are to be separated by a gas-tight bulkhead and/or deck from accommodation, machinery, service and control spaces. Access to such compartments is only to be from the open deck.
- b) Gas piping systems are not to be led through accommodation, service and machinery spaces or control stations.

### 5.3.6 Protection of cargo spaces

- a) Means to protect the cargo spaces from overpressure are to be provided. These means may be:
  - in the case of external gas supply, a shut-off valve automatically operated in the event of overpressure fitted at the connection with the external supply
  - a vent valve, connected to the inlet valve, ensuring that the inlet of nitrogen is allowed when the vent valve is open.
- b) Nitrogen outlets to the atmosphere are to be directed vertically upward and are to be located in segregated positions which are not likely to discharge into manned areas.

### 5.3.7 Ventilation

- a) The gas supply compartment is to be fitted with an independent mechanical extraction ventilation system providing a rate of at least 20 air changes per hour based on the total empty volume of the compartment.
- b) Ventilation ducts from the gas generator/supply compartment are not to be led through accommodation, service and machinery spaces or control stations.
- c) The air exhaust ducts are to be led to a safe location on the open deck.

## 5.4 Miscellaneous equipment

### 5.4.1 Humidification equipment

Where a humidification system is fitted, the following requirements are to be complied with:

- a) the supply of fresh water for humidification is to be such as to minimise the risk of corrosion and contamination of the cargo
- b) in order to prevent damage or blockage in the humidification system caused by water freezing, the air, steam or water pipelines in the cargo chambers are to be

installed so as to facilitate drainage and to be provided with suitable heating arrangements.

**5.4.2 Electrical equipment**

In addition to the applicable requirements of Part C, Chapter 2, the following are to be complied with:

- a) the electrical power for the controlled atmosphere plant is to be provided from a separate feeder circuit from the main switchboard
- b) under seagoing conditions, the number and rating of service generators are to be sufficient to supply the cargo refrigeration machinery and controlled atmosphere equipment in addition to the ship's essential services, when any one generating set is out of action.

**5.5 Gas detection and monitoring equipment**

**5.5.1 General**

- a) The indicators and alarms required in this Section are all to be given at a suitable refrigerated cargo control station.
- b) The pressure in each controlled atmosphere zone is to be monitored and an alarm initiated when the pressure is too high or too low.
- c) Direct read-out of the gas quality within any controlled atmosphere zone is to be available to the operating staff on demand.

**5.5.2 Oxygen and carbon dioxide detection**

- a) All cargo spaces intended for controlled atmosphere are to be fitted with means for measuring the oxygen and carbon dioxide content. The values are to be automatically logged at regular intervals (generally every hour) for the entire period in which the cargo space is kept under controlled atmosphere.
- b) Gas analysers are to be calibrated automatically once every 24 hours. An alarm is to be initiated if accuracy is outside tolerance limits.
- c) Each normally manned space adjacent to cargo spaces, intended to be operated under controlled atmosphere, is to be fitted with at least one means to measure the oxygen content.
- d) When humidification equipment is installed in each of the controlled atmosphere zones, an alarm is to be initiated

ated when the relative humidity falls below or exceeds the predetermined set values.

**5.5.3 Sampling and analysing system**

- a) At least two analysers for oxygen and carbon dioxide having a tolerance of  $\pm 0,1$  per cent by volume are to be provided to determine the content of the circulated gas within the controlled atmosphere zones.
- b) When a sampling system with sequential analysing is fitted, the sampling lines are to be able to operate at any value of pressure or vacuum at which the controlled air system may operate in the cargo space. Common sampling lines for different media (oxygen, carbon dioxide, etc.) are allowed.
- c) Two separate sampling points are to be located in each controlled atmosphere zone and one sampling point in each of the adjacent spaces. The arrangements are to be such as to prevent water condensing and freezing in the sampling lines under normal operating conditions. Filters are to be provided at the inlet to sampling point lines.
- d) Arrangements of the gas sampling points are to be such as to facilitate representative sampling of the gas in the space.
- e) Where gas is extracted from the controlled atmosphere zones via a sampling tube to analysers outside the space, the sample gas is to be discharged safely to the open deck.
- f) Sampling by means of portable equipment will be the subject of special consideration.
- g) The sampling frequency is to be at least once per hour.

**5.5.4 Alarm for gas release**

An audible and visual alarm is to be automatically operated for at least 60 seconds before the gas release in the cargo spaces is initiated. The alarm is to be interlocked with the gas inlet valve, in such a way that the valve cannot be opened until the alarm has been given.

**5.6 Instrumentation, alarm and monitoring arrangement**

**5.6.1** Tab 2 summarises the minimum control and monitoring requirements for controlled atmosphere plants.

**Table 2**

Item	Indicator	Function			Comments
			Alarm	Automatic shut-down	
Oxygen content	percentage	low	X		Cargo spaces
		high	X		
		< 21%	X		Manned spaces adjacent to cargo spaces
Carbon dioxide content	percentage		X		Cargo spaces
Atmospheric pressure	pressure	high	X	X (1)	
Gas generation		failure	X		Failure of any one of the generating equipment



Item	Indicator	Function			Comments
			Alarm	Automatic shut-down	
Gas release		release	X		To be operated for at least 60 seconds before release
Liquid seal level		low	X		Where installed
Ventilation		failure	X		
Sampling line flow		failure	X		
Logging		failure	X		
(1) Automatic closing of inlet valve of externally supplied gas.					

## 5.7 Safety

### 5.7.1 Access to controlled atmosphere zones

- Controlled atmosphere zones are to be clearly labelled with "Caution" and "Danger" signs to alert personnel.
- Entry hatch and manhole covers and doors leading to controlled atmosphere zones and adjacent spaces are to be fitted with acceptable security type locks and warning notices informing about the low oxygen atmosphere. Warning notices are to be posted at all openings to spaces under controlled atmosphere to prevent inadvertent opening while the space is under the controlled atmosphere.
- All doors and access hatches to controlled atmosphere zones which may be under pressure are to open outwards and are to be fitted with means to prevent injury or damage during opening.

### 5.7.2 Safety equipment

- At least 10 portable oxygen monitors with alarms are to be provided on board.
- At least two portable oxygen sensors are to be provided to sample the oxygen level in all controlled atmosphere zones and adjacent spaces for use prior to entry into such zones or spaces.
- A means of two-way communication is to be provided between the cargo spaces under controlled atmosphere and the gas release control station. If portable radiotelephone apparatus is adopted to comply with this requirement, at least three sets are to be provided on board. This equipment is to be in addition to that required by SOLAS Chapter III, Regulation 6.
- Two self-contained breathing apparatuses equipped with built-in radio communication and a lifeline with a belt are to be provided on board together with fully charged spare air bottles with a total free air capacity of 3600 litres for each breathing apparatus. This equipment is to be in addition to that required by SOLAS Chapter II-2, Regulation 17.

## 5.8 Tests and trials

### 5.8.1 General

Controlled atmosphere system trials are to be carried out on board before the system is put into service, as indicated below.

### 5.8.2 Tightness tests

- Piping
  - The gas supply mains and branches are to be pressure and leak tested. The test pressures are to be 1,5 and 1,0 times the design pressure, respectively.
  - All gas sampling lines are to be leak tested using a vacuum or overpressure method.
- Air-tightness in controlled atmosphere
  - Air-tightness of each controlled atmosphere zone is to be tested and the results entered on the certificate. The measured leakage rate of each zone is to be compared with the specified value.
  - Either a constant pressure method or a pressure decay method is to be used to determine the degree of air-tightness.
  - If the constant pressure method is used, the test is to be carried out at the design pressure of the controlled atmosphere zones.
  - If the pressure decay method is used, the time for the pressure to drop from 350 Pa to 150 Pa is to be measured and the leakage is to be calculated using the following formula:

$$Q = 7,095 \cdot \frac{V}{t}$$

where:

- Q : Air leakage, in m<sup>3</sup>/h  
 V : Volume of zone, in m<sup>3</sup>  
 t : Time, in seconds  
 7,095 : Constant for 200 Pa pressure decay.

- During this test, the adjacent zones are to be kept at atmospheric pressure.

### 5.8.3 Gas system performance

The capability of the gas system to supply gas according to the specified flow rate and conditions is to be verified by tests.

### 5.8.4 Gas freeing

The gas freeing arrangements are to be tested to demonstrate that they are effective.

### 5.8.5 Safety, alarms and instrumentation

- The control, alarm and safety systems are to be tested to demonstrate overall satisfactory performance of the con-

trol engineering installation. Testing is also to take account of the electrical power supply arrangements.

- b) Locking arrangements of all controlled atmosphere zones and adjacent spaces where gas may accumulate, provision of warning notices at all entrances to such spaces, communication arrangements and operation of alarms, controls, etc. are to be examined.
- c) The provision of portable gas detectors and personnel oxygen monitors is to be verified. Suitable calibrated instruments to measure the levels of O<sub>2</sub>, CO<sub>2</sub> and humidity, gas pressure and gas flow to the controlled atmosphere zones are to be provided for testing. Their accuracy is to be verified.

## 6 Additional requirements for PRE-COOLING and QUICKFREEZE notations

### 6.1 General

#### 6.1.1 Applicability

The following requirements apply to ships for which either the PRECOOLING or QUICKFREEZE notation is requested. The requirements of this Section are additional to those in Sec 1.

#### 6.1.2 Conditions of assignment

The notations PRECOOLING and QUICKFREEZE are assigned in connection with the maximum time necessary to cool the cells from the ambient temperature to the service temperature with the cargo loaded at the ambient tem-

perature. This time is to be indicated in the contract specification together with the specified temperatures and, upon verification, to be entered in the notation.

#### 6.1.3 Additional requirements for PRECOOLING notation

- a) Unless otherwise specified for special cargoes, the rate of cold air circulation within each space is not normally to be less than 70 changes per hour. Lower values may be accepted locally for zones with lesser ventilation. However, for any zone, in any right parallelepiped having 1 m<sup>2</sup> of ceiling surface as a base and the height of the space, the rate of circulation is not to be less than 40 changes per hour; moreover, the average rate of circulation is not to be less than 60 changes per hour in any parallelepiped with the same height and based on 50 m<sup>2</sup> of ceiling surface.
- b) For a system with horizontal air circulation, the average and local rates of circulation are not to be less than those mentioned above for vertical circulation.
- c) Unless duly justified, the local and average rates of circulation of refrigerated air are to be checked for the empty spaces.

### 6.2 Shipboard tests

#### 6.2.1 Additional requirement for the PRECOOLING notation

For the notation PRECOOLING, during the ventilation system tests the conditions stated in [6.1.3] are to be verified. The detailed procedure of the test is to be previously submitted to the Society.

## SECTION 3

## ADDITIONAL REQUIREMENTS FOR THE NOTATION REF-CONT

### 1 General

#### 1.1 Application

**1.1.1** The requirements of this Section are applicable for the assignment of the additional class notation **REF-CONT**. They are additional to the applicable requirements of Sec 1.

**1.1.2** Where the containers are cooled by a permanently installed refrigerating plant designed to supply refrigerated air to insulated containers carried in holds of container ships, the suffix **(A)** will be added to the notation **REF-CONT**.

Where the ship is intended only to supply electrical power to self-refrigerated containers, the suffix **(E)** will be added to the notation **REF-CONT**.

**1.1.3** Where air conditioning or insulation of the holds is necessary for the carriage of refrigerated containers, the corresponding items are also to be considered for granting the appropriate class notation.

**1.1.4** Refrigerated containers are not covered by the class notation and accordingly no specific requirements for the containers are contained in these Rules.

However, the heat transfer coefficient of the containers is to comply with the value appearing in the notation; see also Sec 1, [1.2.2].

### 2 Refrigerating plants supplying refrigerated air to containers

#### 2.1 Definitions

##### 2.1.1 Batch of containers

A batch of containers or simply a batch is a set of containers served by the same duct and the same air cooler.

##### 2.1.2 Decentralised refrigerating plant

A decentralised refrigerating plant is a plant in which each container is connected on board to a separate unit for cold production and distribution.

#### 2.2 Cold distribution

##### 2.2.1 Systems serving batches of containers

The system of cold distribution of each air cooler serving a batch of containers is to be divided into two distinct parts capable of working separately, each of them being able to ensure the requested cold supply. This requirement need

not be complied with where the air cooler serves no more than 7 standard 40 ft containers (or 14 standard 20 ft containers).

##### 2.2.2 Decentralised refrigerating plants

Fully decentralised fixed refrigerating plants are normally to comply with the same provisions as foreseen for centralised plants. However, while a standby refrigerating unit is not required in this case, at least two compressors, each one able to supply two thirds of the necessary refrigerating capacity (or an equivalent arrangement), are to be provided.

##### 2.2.3 Regulation valves

The regulation valves for supply of brine to air coolers are to be so arranged that they can be isolated, unless it is possible to operate them manually in the case of damage to their automatic control device. However, the manual operation of these valves is not required where it is possible to arrange for their quick replacement while the containers are on board. In such case, the proposed list of spare valves is to be submitted to the Society.

##### 2.2.4 Air cooler fans

Where a single fan is provided for each air cooler, the arrangement is to be such that it is possible to proceed with the disassembling of the fan and/or the associated motor of each air cooler while the containers are on board. In this case, at least one spare fan and one motor of each type are to be available on board.

### 2.3 Equipment and systems

#### 2.3.1 Couplings

The couplings for connection to containers are to be of an approved type.

#### 2.3.2 Compressors

In addition to the compressors which are necessary for the compressed air production system used for the operation of couplings, at least one standby air compressor or equivalent is to be provided. This compressor is to be arranged to be immediately available and its capacity is to be at least equal to that of the largest compressor it is to replace.

#### 2.3.3 Air ducts

- a) Ducts for discharge and suction of refrigerated air are to be suitably insulated; they are to be air-tight in order to avoid an abnormal increase in the cold demand and an abnormal decrease in the temperature of air in the holds.
- b) The insulating materials and linings used for the ducts are to comply with the provisions of Sec 1, [5.4].

### 2.3.4 Other ducts and piping

- a) Ducts for entry of fresh air and exhaust of stale air which serve a batch of containers are to be arranged so that they can be segregated from the ducts serving other batches in order to avoid contamination by odour of the remains of the cargo in case of damage.
- b) Similar provision is to be made in respect of the piping for drainage of defrosting water and condensation products from air coolers. Each drainage pipe is to be fitted with a hydraulic scupper or equivalent.
- c) Ducts for exhaust of stale air are to be led to the open. However, where the holds are sufficiently ventilated (rate of air renewal per hour not normally less than 4), these ducts may be led to the holds.

### 2.3.5 Containers with controlled atmosphere

For containers with controlled atmosphere, see Sec 2, [5.2.4] d).

## 2.4 Thermometers

### 2.4.1 Temperature sensors

- a) At least two temperature sensors are to be provided for each container. One is to be arranged at the air suction, the other at the air supply. The latter may, however, be common to several containers if the arrangements are such that the same air temperature is ensured at all the air supply outlets. In this case, the sensor is to be located at the air cooler exhaust in the air stream common to all these outlets.
- b) The sensors and thermometers are to be of an approved type.

### 2.4.2 Temperature recording

- a) The system for recording the temperature measurements is to be completely duplicated. Where this is not feasible, it is to be possible, in case of failure of the main system or of a main cable, to intervene with the necessary instrument in way of each hold in order to record the temperatures of supply and suction air for each container. In this case, arrangements are to be such that the staff in charge of these measurements can operate from an easily accessible location.
- b) For fully decentralised plants, the duplication is not required provided that a temperature regulator-indicator is provided for the air supply to each container. These devices are to be located together in one or several easily accessible positions.
- c) For plants with more than 200 containers, the temperature monitoring system is to be automated and is to include alarms for low and high temperatures. Proposed arrangements are to be submitted to the Society.
- d) At least 2% of the number of temperature sensors of each type (with a minimum of 5 per type) are to be provided as spares.

## 2.5 Workshop and shipboard inspections and tests

### 2.5.1 Circulating pumps

The characteristics (capacity, pressure and absorbed power) of circulating pumps for cooling media (sea water, brine, refrigerant) are to be checked at the works where the prime movers have an output exceeding 50 kW. The test is to be performed for each type of pump and attended by a Surveyor; at least 3 points suitably distributed over each curve are to be considered.

### 2.5.2 Motors of air cooler fans

Where the Manufacturer cannot indicate the efficiency for each type of motor and for a resisting torque varying from 20% to 100% of the rated couple of this motor, the corresponding measurement may be required during inspection at the works of the motors.

### 2.5.3 Compressors

- a) A check of the refrigerating power of each type of compressor is to be performed for various running conditions. The latter are to correspond, at least, to those foreseen in the heat balance for the extreme operating conditions.
- b) Tests are normally to be performed at the works of the makers. When tests are carried out on board, the proposed procedure is to be approved by the Society.
- c) For identical plants made by the same maker and intended for ships of the same series, tests are only required for the first ship provided that their results are satisfactory.
- d) Direct checking of the refrigerating power is not required where it is intended to perform a test, with all the containers on board, at the lowest temperature and in the extreme operating conditions specified.

### 2.5.4 Air coolers

Where considered necessary taking into account the characteristics of the plant, the Society may require that the distribution of the brine flow to the various air coolers is checked on board.

### 2.5.5 Air ducts

- a) Air-tightness of ducts together with their connections and couplings is to be achieved to the Surveyor's satisfaction. Each duct is to be tested for air-tightness.
- b) Air-tightness of each duct is to be checked after closing of all pipes such as drains and stale air exhausts which are not a source of leakage in normal operation. Two tests are to be performed, the first with all the couplings sealed by tight plugs, the second without such plugs.
- c) The leakage rate  $Q_0$  is to be measured with an overpressure not appreciably less than 0,245 MPa; for a different overpressure  $\Delta P$ , in kPa, the measured leakage rate  $Q$  is to be corrected to obtain  $Q_0$  by the formula:

$$Q_0 = Q \left( \frac{0,245}{\Delta P} \right)^{1/2}$$

The leakage rate  $Q_0$  is not to exceed by more than 5% the values given in Tab 1 multiplied by the number of containers served by the tested duct.

- d) One duct of each type is to be submitted to a test for air distribution to containers. This test includes measurement of the air flow at the various couplings; during the test, the fans run at full speed and at the rated pressure. The air flow at each coupling is not normally to be lower than the specified value, with a minus tolerance of 5%.
- e) The overall heat exchange coefficient is to be determined for at least two different types of ducts; the result is not to exceed by more than 10% the value considered in the heat balance. For large series (at least 50), 2% of the ducts are to be subjected to this test.
- f) In the case of ducts fabricated on board, tests for air-tightness, air distribution, and heat leakage as defined above are to be performed on board after assembly. In this case, after special examination and where there is a large excess of refrigerating capacity, the Society may agree to waive the test mentioned in e).
- g) Testing procedure is to be submitted for approval.

**Table 1**

Type of container	40'	30'	20'	10'
$Q_0$ in m <sup>3</sup> /h (at 15°C, 101,3 kPa)	30 (60)	23 (46)	16 (32)	9 (18)
<b>Note 1:</b> The lower value corresponds to the first test, the larger one to the second test performed without the plugs.				

## 2.6 Temperature measuring and recording devices

### 2.6.1 Temperature sensors

- a) For plants comprising more than 200 temperature sensors for air supply and suction, including those used for regulation of the supply air temperature, the following checks are to be performed:
  - checking of the tightness of the sealings after immersion during 30 minutes under 1 m of water or after an equivalent test
  - checking of the calibration for at least 3 temperatures suitably distributed over the measuring range; to be done immediately after completion of the previous test.
- b) These checks are to be carried out from 2 batches of sensors chosen at different periods (the middle and end of fabrication). At least 1% (with a minimum of 10) of the number of sensors are chosen by the Surveyor to be checked.

### 2.6.2 Temperature monitoring system

A test of the complete temperature monitoring system is to be performed at the Manufacturer's workshop (for each

ship, even in the case of identical plants installed in sister ships) and is to be attended by the Surveyor. However, for small plants equivalent tests may be performed on board.

## 2.7 Shipboard tests

### 2.7.1 Temperature sensors

- a) The correct operation of all temperature sensors for the whole plant is to be checked on board. Installation of sensors, together with their connecting cables, is to be checked for accuracy.
- b) The zero of the sensors located on the air supplies and suctions in the ducts is to be randomly checked. The checking is to be effected by comparison with pure water ice (0°C). At least one sensor for supply and one sensor at the air flow suction side are to be checked.
- c) It is also to be checked that the regulation sensor for supply air gives the same value as the reading sensor, and that there are no abnormal differences for the reading sensors that have not been checked in accordance with this requirement.

### 2.7.2 Ducts

- a) Before checking the correct operation of the ducts and their fittings, it is to be verified that their air-tightness has not been impaired during their handling or their installation on board. The Surveyor may require that tests (smoke tests or equivalent) are performed at random.
- b) The two leakage tests defined in [2.5.5] are to be performed for ducts which have been dismantled in more than two parts for transportation or which have been assembled on board from prefabricated parts. In this case, and except for one duct of each type, these tests need not be carried out at the works. Where, however, they have been already performed at the works, one is to be repeated on board.
- c) The Surveyor may require that the air-tightness is checked at the junction between the couplings and the containers installed on board for the test. This may be done with soapy water or by a similar procedure.
- d) Where fitted in the ducts at the works, electric motors of duct fans are subjected to insulation measurements; this is to be done at random and as agreed with the Surveyor.

### 2.7.3 Running tests

- a) The running of the major components of the fluid systems (refrigerant, cold and hot brine, sea water, air for couplings) and of the regulation, monitoring and alarm systems is to be checked.
- b) The correct running of the plant in automatic operation is to be checked for the specified conditions. Tests are to be performed for the various operating conditions and for at least three ducts of different types which are to be fully fitted up with containers. The satisfactory operation of the whole plant is also to be verified by means of a suitable test.
- c) When there is a plant for air conditioning of the holds, it is to be tested in accordance with Sec 2.

### **3 Ships supplying electrical power to self-refrigerated containers**

#### **3.1 Electrical equipment**

**3.1.1** In addition to the applicable requirements of Part C, Chapter 2, the following are to be complied with:

- a) the electrical power for the controlled atmosphere plant is to be provided from a separate feeder circuit from the main switchboard

- b) under seagoing conditions, the number and rating of service generators are to be sufficient to supply the cargo refrigeration machinery and controlled atmosphere equipment in addition to the ship's essential services, when any one generating set is out of action.

#### **3.2 Installation of containers**

**3.2.1** The loading of refrigerated containers is to be restricted to locations where proper ventilation and cooling of the refrigerating equipment may be ensured.

## **SECTION 4**

## **ADDITIONAL REQUIREMENTS FOR THE NOTATION REF-STORE**

### **1 General**

#### **1.1 Application**

**1.1.1** For the assignment of the additional class notation **REF-STORE**, and in addition to the applicable requirements of Sec 1, the additional requirements of Sec 2 are to be complied with, with the exception of those of Sec 2, [1.3] and Sec 2, [3.1].





Part F  
**Additional Class Notations**

Chapter 9  
**ICE CLASS (ICE)**

---

- SECTION 1      GENERAL**
- SECTION 2      HULL AND STABILITY**
- SECTION 3      MACHINERY**



# SECTION 1

# GENERAL

## 1 General

### 1.1 Application

#### 1.1.1 (1/1/2010)

The following additional class notations are assigned in accordance with Pt A, Ch 1, Sec 2, [6.10] to ships strengthened for navigation in ice and complying with the relevant requirements of this Chapter :

- ICE CLASS IA SUPER
- ICE CLASS IA
- ICE CLASS IB
- ICE CLASS IC
- ICE CLASS ID.

#### 1.1.2 (1/7/2020)

Except for those applicable to ships with the additional class notation **ICE CLASS ID**, the ice strengthening requirements in this Chapter are equivalent to those stated in the "Finnish-Swedish Ice Class Rules, 2017", as adopted by the Finnish Transport Safety Agency (TRAFI) on 1 December 2017", applicable to ships trading in the Northern Baltic Sea in winter.

#### 1.1.3 (1/1/2001)

For the purpose of this Chapter, the notations mentioned in [1.1.1] may be indicated using the following abbreviations:

- IAS for ICE CLASS IA SUPER
- IA for ICE CLASS IA
- IB for ICE CLASS IB
- IC for ICE CLASS IC
- ID for ICE CLASS ID.

### 1.2 Owner's responsibility

**1.2.1** It is the responsibility of the Owner to decide which ice class notation is the most suitable in relation to the expected service conditions of the ship.

Nevertheless, it is to be noted that a ship assigned with the ice class notation **IAS** is not to be considered as a ship suitable for navigation in ice in any environmental condition, such as an icebreaker.

## 2 Ice class draughts and ice thickness

### 2.1 Definitions

#### 2.1.1 Upper and lower ice waterlines (1/1/2012)

a) The upper ice waterline (UIWL) is to be the envelope of the highest points of the waterlines at which the ship is

intended to operate in ice. The line may be a broken line.

b) The lower ice waterline (LIWL) is to be the envelope of the lowest points of the waterlines at which the ship is intended to operate in ice. The line may be a broken line.

#### 2.1.2 Fore and aft draughts (1/7/2020)

The maximum and minimum ice class draughts at fore and aft perpendiculars are to be determined in accordance with the upper and lower ice waterlines and the draught of the ship at fore and aft perpendiculars, when ice conditions require the ship to be ice-strengthened, is always to be between the upper and lower ice waterlines.

#### 2.1.3 Ice belt (1/7/2007)

The ice belt is that portion of the side shell which is to be strengthened; its vertical extension is equal to the required extension of strengthening.

### 2.2 Draught limitations

#### 2.2.1 Maximum draught (1/7/2007)

The draught and trim limited by the UIWL are not to be exceeded when the ship is navigating in ice.

The salinity of the sea water along the intended route is to be taken into account when loading the ship.

#### 2.2.2 Minimum draught (1/7/2020)

The ship is always to be loaded down to at least the LIWL amidship when navigating in ice.

#### 2.2.3 Minimum forward draught (1/7/2020)

In determining the LIWL, due regard is to be paid to the need to ensure a reasonable degree of ice going capability in ballast. The propeller is to be fully submerged, if possible entirely below the ice. The minimum forward draught is to be at least equal to the value  $T_{AV}$ , in m, given by the following formula:

$$T_{AV} = (2 + 0,00025\Delta_1)h_G$$

where:

$\Delta_1$  : Displacement of the ship, in t, on the maximum ice class draught amidships, as defined in [2.2.1]; where multiple waterlines are used for determining the UIWL, the displacement is to be determined from the waterline corresponding to the greatest displacement.

$h_G$  : Ice thickness, in m, as defined in [2.3].

The draught  $T_{AV}$  need not, however, exceed  $4 h_G$ .

**2.2.4 Indication of maximum and minimum draughts (1/7/2007)**

The maximum and minimum ice class draughts fore, amidships and aft are to be specified in the plans submitted for approval to the Society and stated on the Certificate of Classification.

Restrictions on draughts when operating in ice are to be documented and kept on board readily available for the Master.

**2.2.5 Warning triangle (1/7/2007)**

If the summer load line in fresh water is located at a higher level than the UIWL, the ship's sides are to be provided with a warning triangle and with an ice class draught mark at the maximum permissible ice class draught amidships (see Fig 1).

The purpose of the warning triangle is to provide information on the draught limitation of the vessel when it is sailing

in ice for Masters of icebreakers and for inspection personnel in ports.

The upper edge of the warning triangle is to be located vertically above the "ICE" mark, 1000 mm higher than the summer load line in fresh water but in no case higher than the deck line. The sides of the triangle are to be 300 mm in length.

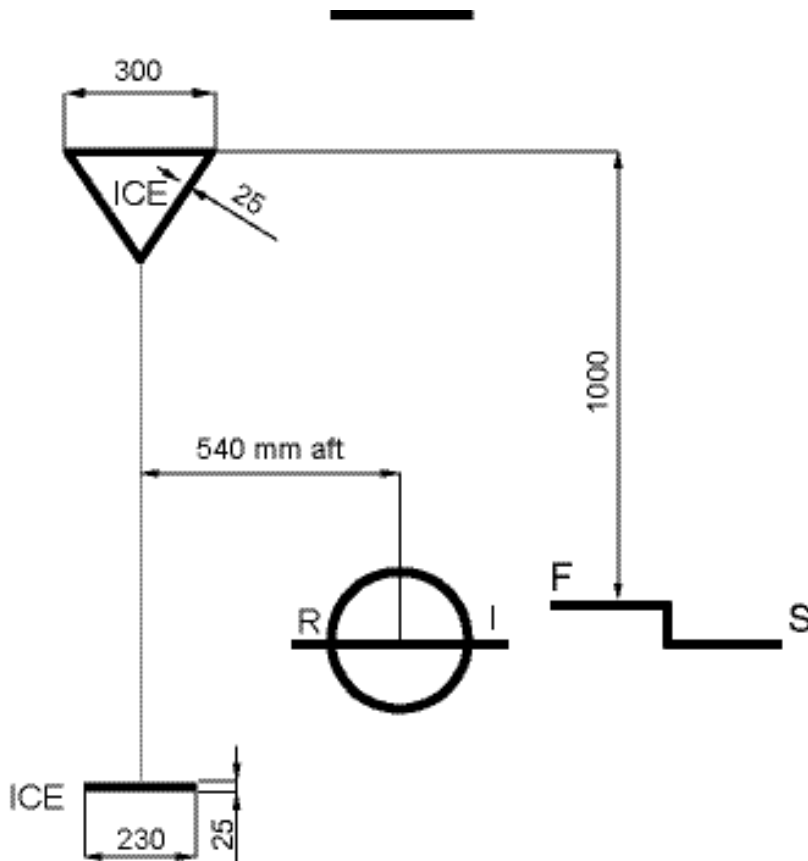
The ice class draught mark is to be located 540 mm abaft the centre of the load line ring or 540 mm abaft the vertical line of the timber load line mark, if applicable.

The marks and figures are to be cut out of 5 - 8 mm plate and then welded to the ship's side.

The marks and figures are to be painted in a red or yellow reflecting colour so that they are plainly visible even in ice conditions.

The dimensions of all figures are to be the same as those used in the load line mark.

**Figure 1 : Warning triangle (1/7/2007)**



## 2.3 Ice thickness

### 2.3.1

- An ice strengthened ship is assumed to operate in open sea conditions corresponding to a level ice with a thickness not exceeding the value  $h_G$ .
- The design height of the area actually under ice pressure at any time is, however, assumed to be only a fraction  $h$ , of the ice thickness  $h_G$ .
- The values for  $h_G$  and  $h$ , in m, are given in Tab 1.

**Table 1**

Ice class notation	$h_G$ (m)	$h$ (m)
<b>IAS</b>	1,0	0,35
<b>IA</b>	0,8	0,30
<b>IB</b>	0,6	0,25
<b>IC</b>	0,4	0,22

## 3 Output of propulsion machinery

### 3.1 Required engine output

#### 3.1.1 Definitions (1/7/2020)

The engine output  $P$  is the total maximum output that the propulsion machinery can continuously deliver to the propeller.

If the output of the machinery is restricted by technical means or by any regulation applicable to the ship,  $P$  is to be taken as the restricted output.

If additional power sources are available for propulsion power (e.g. shaft motors), in addition to the power of the main engine(s), they are also to be included in the total engine output.

The dimensions of the ship, defined below, are measured on the maximum ice class draught of the ship as defined in [2.2.1]. For the symbol definitions, see also Fig 2.

- $L$  : Length of the ship between the perpendiculars, in m
- $L_{BOW}$  : Length of the bow, in m
- $L_{PAR}$  : Length of the parallel midship body, in m
- $B$  : Maximum breadth of the ship, in m
- $T$  : Maximum ice class draught of the ship, in m, according to [2.2.1]
- $A_{wf}$  : Area of the waterline of the bow, in  $m^2$
- $\alpha$  : Angle of the waterline at  $B/4$ , in deg
- $\phi_1$  : Rake of the stem at the centreline, in deg
- $\phi_2$  : Rake of the bow at  $B/4$ , in deg
- $\psi$  : Flare angle calculated as  $\psi = \arctan(\tan\phi / \sin\alpha)$

using angles  $\alpha$  and  $\phi$  at each location, in deg.

Within this Article [3] flare angle is to be calculated using  $\phi = \phi_2$

- $D_p$  : Diameter of the propeller, in m
- $H_M$  : Thickness of the brash ice in mid-channel, in m
- $H_F$  : Thickness of the brash ice layer displaced by the bow, in m.

#### 3.1.2 Minimum required power for IAS, IA, IB, IC (1/9/2003)

The power of the propulsion machinery is to be not less than the value  $P_{MIN}$ , in kW, determined by the following formula, but in no case less than 1000 kW for **IA, IB, IC** and not less than 2800 kW for **IAS**:

$$P_{MIN} = K_C \frac{\left(\frac{R_{CH}}{1000}\right)^{3/2}}{D_p}$$

where:

$K_C$  : to be taken from Tab 2

$R_{CH}$  : Resistance of the ship in a channel with brash ice and a consolidated layer, in N, equal to:

$$R_{CH} = C_1 + C_2 + C_3 C_\mu (H_F + H_M)^2 (B + C_\psi H_F) + C_4 L_{PAR} H_F^2 + C_5 \left(\frac{LT}{B^2}\right)^3 (A_{wf}/L)$$

with:

$H_F$  :  $0,26 + (H_M B)^{0,5}$

$H_M$  : 1,0 for **IAS** and **IA**; 0,8 for **IB**; 0,6 for **IC**

$C_\mu$  :  $0,15 \cos \phi_2 + \sin \psi \sin \alpha$ , to be taken equal to or greater than 0,45

$C_\psi$  :  $0,047\psi - 2,115$ , to be taken as 0 if  $\psi \leq 45^\circ$

$C_1$  : Coefficient taking into account a consolidated upper layer of the brash ice and to be taken:

- for ice class **IA, IB** and **IC**:

$$C_1 = 0$$

- for ice class **IAS**:

$$C_1 = f_1 \frac{BL_{PAR}}{2T} + (1 + 0,021\phi_1)(f_2 B + f_3 L_{BOW} + f_4 BL_{BOW})$$

$C_2$  : Coefficient taking into account a consolidated upper layer of the brash ice and to be taken:

- for ice class **IA, IB** and **IC**:

$$C_2 = 0$$

- for ice class **IAS**:

$$C_2 = (1 + 0,063\phi_1)(g_1 + g_2 B) + g_3 \left(1 + 1,2 \frac{T}{B}\right) \frac{B^2}{L^{0,5}}$$

where:

$\phi_1$  : to be taken equal to  $90^\circ$  for ships with bulbous bow

$f_1$  : 23 N/m<sup>2</sup>

$f_2$  : 45,8 N/m<sup>2</sup>

$f_3$  : 14,7 N/m<sup>2</sup>

$f_4$  : 29 N/m<sup>2</sup>

$g_1$  : 1530 N

$g_2$  : 170 N/m

$g_3$  : 400 N/m<sup>1,5</sup>

$C_3$  : 845 kg/m<sup>2</sup>s<sup>2</sup>

$C_4$  : 42 kg/m<sup>2</sup>s<sup>2</sup>

$C_5$  : 825 kg/s<sup>2</sup>

$\psi$  :  $\arctan(\tan \phi_2 / \sin \alpha)$

$\left(\frac{LT}{B^2}\right)^3$  is not to be taken less than 5 and greater than 20.

**Table 2 : Values of  $K_C$  for conventional propulsion systems (1/7/2020)**

Number of propellers	CP propellers or electric or hydraulic propulsion machinery	FP propellers
1 propeller	2,03	2,26
2 propellers	1,44	1,60
3 propellers	1,18	1,31

**3.1.3 Other methods of determining  $K_C$  or  $R_{CH}$  (1/9/2003)**

The Society may for an individual ship, in lieu of the  $K_C$  or  $R_{CH}$  values defined above, approve the use of  $K_C$  values based on more exact calculations or  $R_{CH}$  values based on model tests. Such approval will be given on the understanding that it can be revoked if experience of the ship's performance in practice warrants this.

The design requirement for ice classes is a minimum speed of 5 knots in the following brash ice channels:

- IAS** :  $H_M = 1,0$  m and a 0,1 m thick consolidated layer of ice
- IA** :  $H_M = 1,0$  m
- IB** :  $H_M = 0,8$  m
- IC** :  $H_M = 0,6$  m

**3.1.4 Minimum required power for class ID (1/1/2001)**

The power of the propulsion machinery is to be not less than the value P, in kW, determined by the following formula:

$P = 0,72LB$

**3.1.5 Range of validity (1/9/2003)**

The range of validity of the formulae for powering requirements in [3.1.2] is presented in Tab 3.

When calculating the parameter  $D_p/T$ , T is to be measured at UIWL.

If the ship parameter values are beyond the ranges defined in Tab 3, other methods for defining  $R_{CH}$  are to be used, as defined in [3.1.3].

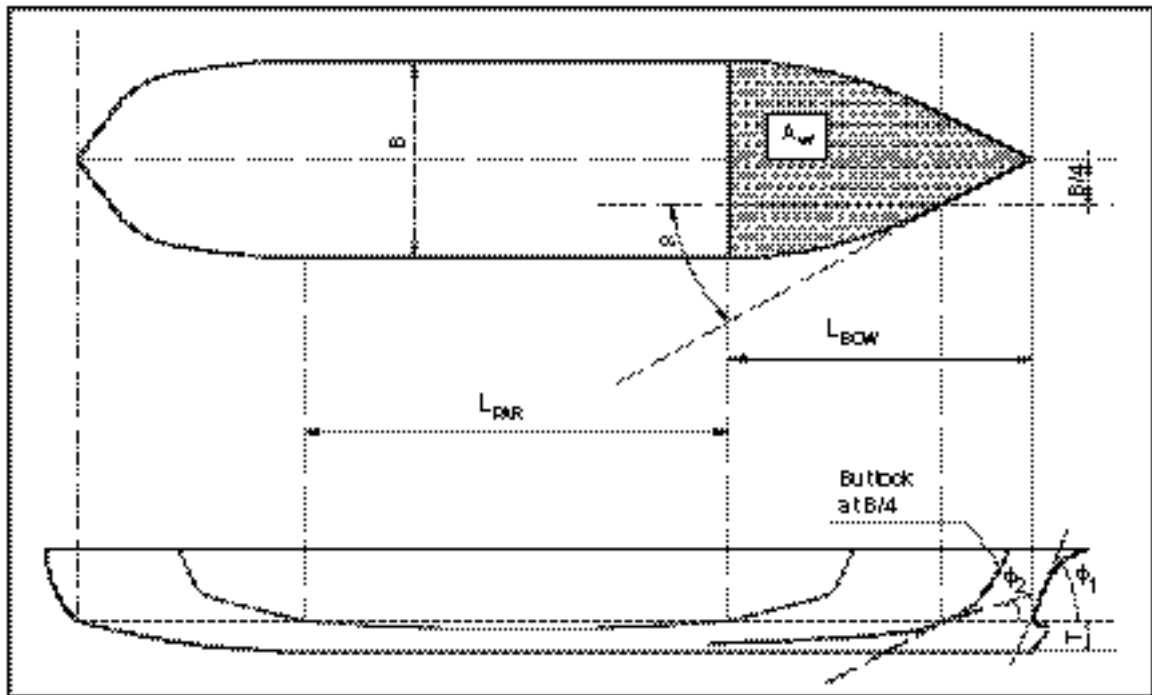
**Table 3 : Range of parameters used for validation of the powering requirements (1/9/2003)**

Parameter	Minimum	Maximum
$\alpha$ [degrees]	15	55
$\phi_1$ [degrees]	25	90
$\phi_2$ [degrees]	10	90
L [m]	65,0	250,0
B [m]	11,0	40,0
T [m]	4,0	15,0
$L_{BOW} / L$	0,15	0,40
$L_{PAR} / L$	0,25	0,75
$D_p / T$	0,45	0,75
$Awf / (L * B)$	0,09	0,27

**3.1.6 Indication of minimum required power (1/7/2004)**

The minimum required power is to be stated on the Certificate of Classification.

Figure 2



## SECTION 2

## HULL AND STABILITY

### Symbols

UIWL	: Load Waterline, defined in Sec 1, [2.1.2]
LIWL	: Ballast Waterline, defined in Sec 1, [2.1.2]
s	: Spacing, in m, of ordinary stiffeners or primary supporting members, as applicable
$\ell$	: Span, in m, of ordinary stiffeners or primary supporting members, as applicable
$R_{eH}$	: Minimum yield stress, in N/mm <sup>2</sup> , of the material as defined in Pt B, Ch 4, Sec 1, [2].

### 1 Definitions

#### 1.1 Ice strengthened area

##### 1.1.1 General

The vertical extension of the ice strengthened area (see Fig 1) is defined in:

- Tab 1 for plating
- Tab 2 for ordinary stiffeners and primary supporting members.

##### 1.1.2 Fore foot

The fore foot is the area below the ice strengthened area defined in [1.1.1] extending from the stem to a position five ordinary stiffener spaces aft of the point where the bow profile departs from the keel line (see Fig 1).

##### 1.1.3 Upper fore ice strengthened area

The upper fore is the area extending from the upper limit of the ice strengthened area defined in [1.1.1] to 2 m above and from the stem to a position at least 0,2L aft of the forward perpendicular (see Fig 1).

#### 1.2 Regions

##### 1.2.1 General (1/1/2001)

For the purpose of the assignment of the notations **ICE CLASS IA SUPER**, **ICE CLASS IA**, **ICE CLASS IB**, **ICE CLASS IC** and **ICE CLASS ID**, the ice strengthened area defined in

[1.1.1] is divided into three regions defined in [1.2.2], [1.2.3], [1.2.4] and shown in Fig 1.

##### 1.2.2 Fore region (1/1/2001)

The fore region is the region from the stem to a line parallel to and 0,04L aft of the forward borderline of the part of the hull where the waterlines run parallel to the centreline.

The overlap with the borderline need not exceed:

- 6 m for the notations **ICE CLASS IA SUPER** and **ICE CLASS IA**
- 5 m for the notations **ICE CLASS IB**, **ICE CLASS IC** and **ICE CLASS ID**.

**Table 1 : Vertical extension of ice strengthened area for plating (1/1/2012)**

Notation	Region	Vertical extension of ice strengthened area, in m	
		above UIWL	below LIWL
<b>ICE CLASS IA SUPER</b>	Fore region	0,60	1,20
	Midship region		
	Aft region		1,0
<b>ICE CLASS IA</b>	Fore region	0,50	0,90
	Midship region		0,75
	Aft region		
<b>ICE CLASS IB</b> <b>ICE CLASS IC</b>	Fore region	0,40	0,70
	Midship region		0,60
	Aft region		
<b>ICE CLASS ID</b>	Fore region	0,40	0,60



Figure 1 : Ice strengthened area and regions

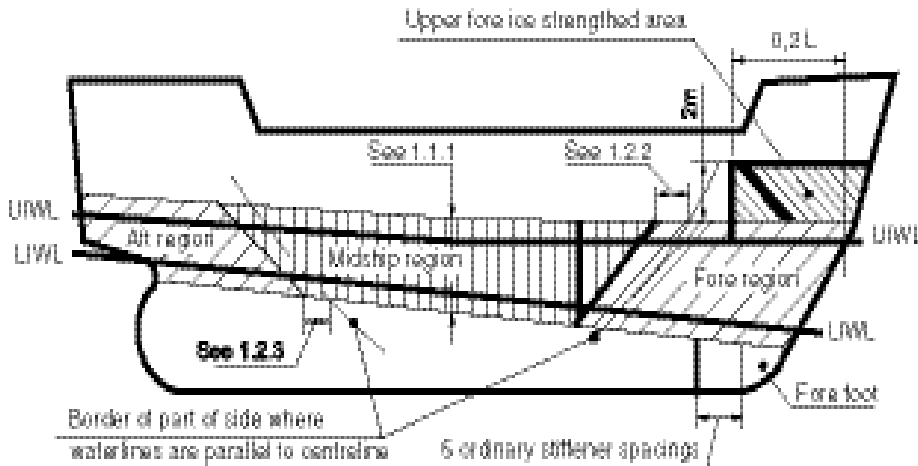


Table 2 : Vertical extension of ice strengthening for ordinary stiffeners and primary supporting members (1/7/2020)

Notation	Region	Vertical extension of ice strengthened area, in m,	
		above UIWL	below LIWL
ICE CLASS IA SUPER	Fore region	1,2	Down to double bottom or below top of floors
	Midship region		2,0
	Aft region		1,6
ICE CLASS IA ICE CLASS IB ICE CLASS IC	Fore region	1,0	1,6
	Midship region		1,3
	Aft region		1,0
ICE CLASS ID	Fore region	1,0	1,0

**Note 1:** Where an upper fore ice strengthened area is required (see [5.1.1]), the ice strengthened part of the ordinary stiffeners is to extend at least to the top of the ice strengthened area.

**Note 2:** Where the ice strengthened area extends beyond a deck or tank top by not more than 250 mm, it may be terminated at that deck or tank top.

**1.2.3 Midship region**

The midship region is the region from the aft boundary of the fore region to a line parallel to and 0,04L aft of the aft borderline of the part of the hull where the waterlines run parallel to the centreline.

The overlap with the borderline need not exceed:

- 6 m for the notations ICE CLASS IA SUPER and ICE CLASS IA
- 5 m for the notations ICE CLASS IB and ICE CLASS IC.

**1.2.4 Aft region**

The aft region is the region from the aft boundary of the midship region to the stern.

**2 Steels for hull structure**

**2.1 Grades of steel**

**2.1.1 (1/7/2014)**

In addition to the requirements specified in Pt B, Ch 4, Sec 1, [2.4], apply the material grade as specified in Tab 3 to the hull structure steels of ships with ice strengthening.

Table 3 : Minimum Material Grades for ships with ice strengthening (1/7/2014)

Structural member category	Material grade
Shell strakes in way of ice strengthening area for plates	Grade B/AH

**3 Structure design principles**

**3.1 General framing arrangement**

**3.1.1 (1/9/2003)**

Within the ice strengthened area defined in [1.1.1], all ordinary stiffeners are to be attached to the supporting structure by means of brackets having the same thickness as the frame web.

Ordinary stiffeners are to be connected to the structure of primary supporting members on both sides (i.e. a free edge of a scallop is to be connected to the ordinary stiffener by collar plates, as shown in Fig 2).

**3.1.2 (1/7/2020)**

For the following regions of ice strengthened area:

- all regions of ships with the notation **ICE CLASS IA SUPER**
- fore and midship regions of ships with the notation **ICE CLASS IA**
- fore region of ships with the notations **ICE CLASS IB, ICE CLASS IC** or **ICE CLASS ID**,

the requirements which follow are to be complied with:

- ordinary stiffeners which are not at a right angle to the shell or with unsymmetrical profile and which have span exceeding 4000 mm are to be supported to prevent tripping by means of brackets, intercostals, stringers or similar at a distance not exceeding 1300 mm

If the span is less than 4000 mm, the support against tripping is required for ordinary stiffeners which are not at a right angle to the shell and with unsymmetrical profile.

- ordinary stiffeners are to be attached to the shell by double continuous welds; no scalloping is allowed (except when crossing shell plate butts)
- the web thickness  $t_w$  of ordinary stiffeners is to be at least as much as the greatest of the values obtained from the following formulae, in mm:

$$t_w = \frac{h_w \sqrt{R_{eH}}}{C}$$

$$t_w = 25s \text{ for transverse framing}$$

$$t_w = 0,5t_p$$

$$t_w = 9$$

where:

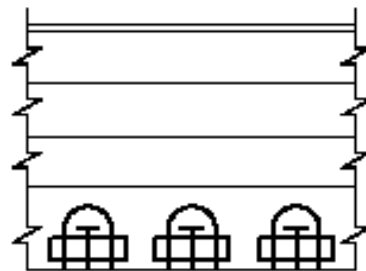
- $h_w$  : web height of the ordinary stiffener, in mm
- $C$  : coefficient depending on the type of profile, to be taken as:  
 $C = 282$  for flat bars  
 $C = 805$  in other cases
- $t_p$  : net thickness of the shell plate,  $t-t_c$ , where  $t$  is to be calculated in accordance with [5.1.2] using the  $R_{eH}$  of the ordinary stiffeners.

Where there is a deck, tank top or bulkhead in lieu of an ordinary stiffener, the plate thickness is to be complied with to a depth corresponding to the height of adjacent ordinary stiffeners.

Asymmetrical ordinary stiffeners and ordinary stiffeners which are not at right angles to the shell (web less than 90 degrees to the shell) are to be supported against tripping by

brackets, intercostals, stringers or similar, at a distance not exceeding 1,300 mm. For ordinary stiffeners with spans greater than 4 m, the extent of antitripping supports is to be applied to all regions and for all ice classes. For ordinary stiffeners with spans less than or equal to 4 m, the extent of antitripping supports is to be applied to all regions for ice class IA Super, to the fore and midship regions for ice class IA, and to the fore region for ice classes IB and IC. Direct calculation methods to demonstrate the equivalent level of support provided by alternative arrangements may be accepted by the Society on a case-by-case basis.

**Figure 2 : End connection of ordinary stiffener  
Two collar plates**



**3.2 Transverse framing arrangement**

**3.2.1 Upper end of transverse framing (1/1/2012)**

The upper end of the strengthened part of a main ordinary stiffener and intermediate ice ordinary stiffener is to be attached to a deck or an ice side girder as required in [5.3.1] and [5.3.2].

Where an intermediate ordinary stiffener terminates above a deck or an ice side girder which is situated at or above the upper limit of the ice strengthened area, the part above the deck or side girder may have the scantlings required for an unstrengthened ship and the upper end may be connected to the adjacent main ordinary stiffeners by a horizontal member of the same scantlings as the main ordinary stiffener.

**3.2.2 Lower end of transverse framing**

The lower end of the strengthened part of a main ordinary stiffener and intermediate ice ordinary stiffener is to be attached to a deck, a tank top or an ice side girder as required in [5.3.1] and [5.3.2].

Where an intermediate ordinary stiffener terminates below a deck, a tank top or an ice side girder which is situated at or below the lower limit of the ice strengthened area, the lower end may be connected to the adjacent main ordinary stiffeners by a horizontal member of the same scantlings as the ordinary stiffeners.

**3.3 Bilge keels**

**3.3.1** The connection of bilge keels to the hull is to be so designed that the risk of damage to the hull, in the event of a bilge keel being ripped off, is minimised.

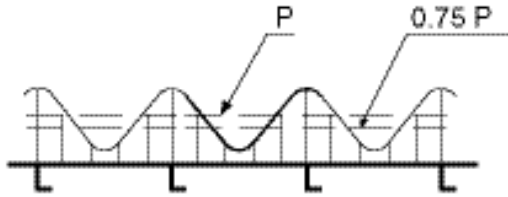
For this purpose, it is recommended that bilge keels are cut up into several shorter independent lengths.

## 4 Design loads

### 4.1 General

4.1.1 Because of the different flexural stiffness of plating, ordinary stiffeners and primary supporting members, the ice load distribution is to be assumed to be as shown in Fig 3.

Figure 3 : Ice load distribution on ship side



#### 4.1.2 Use of direct analysis (1/1/2012)

The formulae and values given in this Section may be substituted by direct analysis if they are deemed by the Society to be invalid or inapplicable for a given structural arrangement or detail, on a case-by-case basis.

Otherwise, direct analysis is not to be utilised as an alternative to the analytical procedures prescribed by explicit requirements in [5].

#### 4.1.3 Requirements for direct analysis (1/1/2012)

Direct analyses are to be carried out using the load patch defined in [4.2] ( $p$ ,  $h$  and  $l_a$ ). The pressure to be used is  $1,8p$  where  $p$  is determined according to [4.2.2]. The load patch is to be applied at locations where the capacity of the structure under the combined effects of bending and shear is minimised. In particular, the structure is to be checked with load centred at the UIWL,  $0,5h_G$  below the LIWL,  $h_G$  being defined in Sec 1, [2.3.1], and positioned at several vertical locations in between. Several horizontal locations are also to be checked, especially the locations centred at the mid-span or -spacing. Further, if the load length  $l_a$ , as defined in [4.2.2], cannot be determined directly from the arrangement of the structure, several values of  $l_a$  are to be checked using corresponding values for  $c_a$ .

The acceptance criterion for designs is that the combined stresses from bending and shear, using the Von Mises yield criterion, are lower than the yield point  $R_{eH}$ . When the direct calculation is using beam theory, the allowable shear stress is not to be larger than:

$$0,9R_{eH}/\sqrt{3}$$

If scantlings obtained from the requirements of this Section are less than those required for the unstrengthened ship, the latter are to be used.

## 4.2 Ice loads

### 4.2.1 Height of load area

The height of the area under ice pressure at any particular point of time is to be obtained, in m, from Tab 4 depending on the additional class notation assigned to the ship.

Table 4 : Height of load area for the different ice classes (1/7/2020)

Notation	$h$ , in m
ICE CLASS IA SUPER	0,35
ICE CLASS IA	0,30
ICE CLASS IB	0,25
ICE CLASS IC ICE CLASS ID	0,22

### 4.2.2 Design ice pressure (1/7/2020)

The value of the design ice pressure  $p$ , in  $N/mm^2$ , to be considered for the scantling check, is obtained from the following formula:

$$p = c_d c_p c_a p_o$$

where:

$c_d$  : Coefficient taking account of the influence of the size and engine output of the ship, to be obtained from the following formula and not to be taken greater than 1:

$$c_d = \frac{a f + b}{1000}$$

$a, b$  : Coefficients defined in Tab 5

Table 5 : Coefficients  $a, b$  for the different hull areas (1/7/2020)

Region (see [1.2])	Condition	$a$	$b$
Fore region	$f \leq 12$	30	230
	$f > 12$	6	518
Midship and aft regions	$f \leq 12$	8	214
	$f > 12$	2	286

$f$  : Coefficient to be obtained from the following formula:

$$f = \frac{\sqrt{\Delta} P}{1000}$$

$\Delta$  : Displacement, in t, at the maximum ice class draught (see Sec 1, [2.1.1])

$P$  : Actual continuous output of propulsion machinery, in kW (see Sec 1, [3]) available when sailing in ice. If additional power sources are available for propulsion power (e.g. shaft motors) in addition to the power of the main engine(s), they also are to be included in the total engine output used as the basis for hull scantling calculations. The engine output used

for the calculation of the hull scantlings is to be clearly stated on the shell expansion drawing.

$c_p$  : Coefficient that reflects the magnitude of the load expected in the hull area in question, relative to the bow area, for the additional class notation considered, defined in Tab 6

$c_a$  : Coefficient taking account of the probability that the full length of the area under consideration will be under pressure at the same time, to be obtained from the following formula:

$$c_a = \sqrt{\frac{\ell_0}{\ell_a}}$$

without being taken less than 0,35 or greater than 1,0, with  $\ell_0 = 0,6$  m

$\ell_a$  : Distance, in m, defined in Tab 7

$p_o$  : Nominal ice pressure, in N/mm<sup>2</sup>, to be taken equal to 5,6.

## 5 Hull scantlings

### 5.1 Plating

#### 5.1.1 General (1/7/2020)

The plating thickness is to be strengthened according to [5.1.2] within the strengthened area for plating defined in [1.1.1].

In addition, the plating thickness is to be strengthened in the following cases:

- For the notation **ICE CLASS IA SUPER**, the thickness within the fore foot is to be not less than that required for the ice strengthened area in the bow region
- For the notations **ICE CLASS IA SUPER** or **ICE CLASS IA**, on ships with an open water service speed equal to or exceeding 18 knots, the shell plate from the upper limit of the ice strengthened area for plating to 2 m above it and from the stem to a position at least 0,2 L abaft of the forward perpendicular shall be ice strengthened in the same way as the midship region.

A similar strengthening of the bow region is recommended also for a ship with a lower service speed, when it is evident, e.g. on the basis of model tests, that the ship will have a high bow wave.

#### 5.1.2 Plating thickness in the ice strengthened area (1/1/2012)

The thickness of the shell plating is to be not less than the value obtained, in mm, from the following formulae:

- for transverse framing:

$$t = 667s \sqrt{\frac{F_1 P_{PL}}{R_{eH}}} + t_c$$

- for longitudinal framing:

$$t = 667s \sqrt{\frac{P}{F_2 R_{eH}}} + t_c$$

**Table 6 : Coefficient  $c_p$  for the different hull areas (1/7/2020)**

Region (see [1.2])	Notation				
	ICE CLASS IA SUPER	ICE CLASS IA	ICE CLASS IB	ICE CLASS IC	ICE CLASS ID
Fore region	1,0	1,0	1,0	1,0	1,0
Midship region	1,0	0,85	0,70	0,50	not applicable
Aft region	0,75	0,65	0,45	0,25	not applicable

**Table 7 : Distance  $l_a$  for the different structural elements (1/7/2020)**

Structure	Type of framing	$l_a$
Shell plating	Transverse	Spacing of ordinary stiffeners
	Longitudinal	1,7 times the spacing of ordinary stiffeners
Ordinary stiffeners	Transverse	Spacing of ordinary stiffeners
	Longitudinal	Span of ordinary stiffeners
Vertical primary supporting members		Two spaces of vertical primary supporting members
Ice side girders		Span of side girders

where:

$p_{PL}$  : Ice pressure on the shell plating to be obtained, in N/mm<sup>2</sup>, from the following formula:

$$p_{PL} = 0,75p$$

$p$  : Design ice pressure, in N/mm<sup>2</sup>, defined in [4.2.2]

$F_1$  : Coefficient to be obtained from the following formula:

$$F_1 = 1,3 - \frac{4,2}{\left[\frac{h}{s} + 1,8\right]^2}$$

without being taken greater than 1,0

$F_2$  : Coefficient to be obtained from the following formulae:

- for  $h/s \leq 1,0$ :

$$F_2 = 0,6 + 0,4 \frac{s}{h}$$



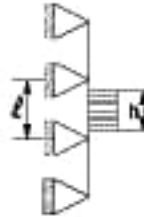
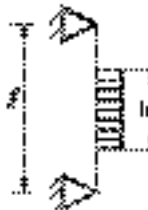
- for  $1,0 < h/s < 1,8$ :

$$F_2 = 1,4 - 0,4 \frac{h}{s}$$

$h$  : Height, in m, of load area defined in [4.2.1]

$t_c$  : Abrasion and corrosion addition, in mm, to be taken equal to 2 mm; where a special surface coating, shown by experience to be capable of withstanding the abrasion of ice, is applied, a lower value may be accepted by the Society on a case-by-case basis.

**Table 8 : Coefficient  $m_0$  (1/9/2003)**

Boundary condition	Example	$m_0$
Type 1	Frames in a bulk carrier with top wing tanks 	7,0
Type 2	Ordinary stiffeners extending from the tank top to a single deck 	6,0
Type 3	Continuous ordinary stiffeners between several decks or side girders 	5,7
Type 4	Ordinary stiffeners extending between two decks only 	5,0
<p><b>Note 1:</b>The boundary conditions are those for main and intermediate ordinary stiffeners.</p> <p><b>Note 2:</b>Load is applied at mid-span.</p>		

## 5.2 Ordinary stiffeners

### 5.2.1 General (1/9/2003)

Ordinary stiffeners are to be strengthened according to [5.2.2] within the strengthened area for ordinary stiffeners defined in [1.1.1].

Where less than 15% of the ordinary stiffener span is located within the ice strengthened area defined in [1.1.1], it is not necessary to increase the scantlings of ordinary stiffeners.

### 5.2.2 Scantlings of transverse ordinary stiffeners (1/1/2012)

The section modulus  $w$ , in  $\text{cm}^3$  and shear are  $A_{sh}$ , in  $\text{cm}^2$ , of transverse ordinary stiffeners are to be not less than the values obtained from the following formulae:

$$w = \frac{7-5(h/\ell)}{7m_0} \frac{psh\ell}{R_{eH}} 10^6$$

$$A_{sh} = \frac{0,87F_{3t}psh}{R_{eH}} 10^4$$

where:

$p$  : Design ice pressure, in  $\text{N/mm}^2$ , defined in [4.2.2]

$h$  : Height, in m, of load area defined in [4.2.1]

$m_0$  : Coefficient defined in Tab 8.

$F_{3t}$  : Coefficient taking account of the maximum shear force versus load location and the shear force distribution for transverse stiffening, to be taken equal to 1,2.

### 5.2.3 Scantlings of longitudinal ordinary stiffeners (1/7/2020)

The section modulus  $w$ , in  $\text{cm}^3$  and the shear area  $A_{sh}$ , in  $\text{cm}^2$ , of longitudinal ordinary stiffeners are to be not less than the values obtained from the following formulae:

$$w = \frac{F_3ps\ell^2}{m_1R_{eH}} 10^6$$

$$A_{sh} = \frac{0,87F_3F_4ps\ell}{R_{eH}} 10^4$$

where:

$F_3$  : Coefficient, taking account of the load distribution on adjacent ordinary stiffeners, to be obtained from the following formula:

$$F_3 = \left(1 - 0,2\frac{h}{s}\right)$$

$h$  : Height, in m, of load area defined in [4.2.1]

$F_4$  : Coefficient taking account of the maximum shear force versus load location and the shear force distribution, to be taken equal to 2,16

$p$  : Design ice pressure, in  $\text{N/mm}^2$ , defined in [4.2.2]

$m_1$  : Boundary condition coefficient for the ordinary stiffener considered, to be taken equal to 13,3 for a continuous beam with brackets.

Where boundary conditions deviate significantly from those of a continuous beam, e.g. in an end field, a smaller value is to be adopted.

## 5.3 Primary supporting members

### 5.3.1 Ice side girders within the ice strengthened area (1/1/2012)

The section modulus  $w$ , in  $\text{cm}^3$  and the section area  $A_{sh}$ , in  $\text{cm}^2$ , of a side girder located within the ice strengthened area defined in [1.1.1] are to be not less than the values obtained from the following formulae:

$$w = \frac{F_5F_7ph\ell^2}{m_sR_{eH}} 10^6$$

$$A_{sh} = \frac{0,87F_5F_7F_8ph\ell}{R_{eH}} 10^4$$

where:

$p$  : Design ice pressure, in  $\text{N/mm}^2$ , defined in [4.2.2]

$h$  : Height, in m, of load area defined in [4.2.1], without the product  $ph$  being taken less than 0,3

$m_s$  : Boundary condition coefficient for the ordinary stiffener considered, to be taken equal to 13,3 for a continuous beam

$F_5$  : Coefficient taking account of the distribution of load to the transverse ordinary stiffeners, to be taken equal to 0,9.

$F_7$  : Safety factor of ice side girders, to be taken equal to 1,8.

$F_8$  : Coefficient taking into account the maximum shear force versus load location and the shear stress distribution, to be taken equal to 1,2.

### 5.3.2 Ice side girders outside the ice strengthened area (1/1/2012)

The section modulus  $w$ , in  $\text{cm}^3$  and the section area  $A_{sh}$ , in  $\text{cm}^2$ , of a side girder located outside the ice strengthened area, defined in [1.1.1], but supporting ice strengthened ordinary stiffeners are to be not less than the values obtained from the following formulae:

$$w = \frac{F_6F_7ph\ell^2}{m_sR_{eH}} \left(1 - \frac{h_s}{\ell_s}\right) 10^6$$

$$A_{sh} = \frac{0,87F_6F_7F_8ph\ell}{R_{eH}} \left(1 - \frac{h_s}{\ell_s}\right) 10^4$$

where:

$p$  : Design ice pressure, in  $\text{N/mm}^2$ , defined in [4.2.2]

$h$  : Height, in m, of load area defined in [4.2.1], without the product  $ph$  being taken less than 0,15

$m_s$  : Coefficient defined in [5.3.1]

- $F_6$  : Coefficient taking account of the load distribution to transverse side girders, to be taken equal to 0,80
- $F_7, F_8$  : Coefficients defined in [5.3.1]
- $h_s$  : Distance to the ice strengthened area, in m
- $\ell_s$  : Distance to the adjacent ice side girder, in m.

### 5.3.3 Vertical primary supporting member checked through simplified model (1/1/2012)

For vertical primary supporting members which may be represented by the structure model represented in Fig 4, the section modulus  $w$ , in  $\text{cm}^3$ , and the shear area  $A_{sh}$ , in  $\text{cm}^2$ , are to be not less than the values obtained from the following formulae:

$$w = \frac{0,193F\ell}{R_{eH}} \left( \frac{1}{1 - (vA_{sh}/A_a)^2} \right)^{\frac{1}{2}} 10^3$$

$$A_{sh} = \frac{17,3\alpha F_9 F}{R_{eH}}$$

where:

- $F_9$  : coefficient taking into account the shear force distribution, to be taken equal to 1,1
- $F$  : Load transferred to a vertical primary supporting member from a side girder or from longitudinal ordinary stiffeners, to be obtained, in kN, from the following formula:
- $$F = F_{10} p h_s 10^3$$
- $F_{10}$  : Safety factor of vertical primary supporting members, to be taken equal to 1,8
- $p$  : Design ice pressure, in  $\text{N/mm}^2$ , defined in [4.2.2], where the value of  $c_a$  is to be calculated assuming  $\ell_a$  equal to 2s
- $h$  : Height, in m, of load area defined in [4.2.1], without the product  $ph$  being taken less than 0,15
- $v$  : Coefficient defined in Tab 9
- $A_a$  : Actual cross-sectional area of the vertical primary supporting member
- $\alpha$  : Coefficient defined in Tab 9
- $\ell_F$  : Distance, in m, as indicated in Fig 4; for the lower part of the vertical primary supporting member the smallest  $\ell_F$  within the ice strengthened area is to be used and for the upper part of the vertical primary supporting member the largest  $\ell_F$  within the ice strengthened area is to be used.

Figure 4 : Reference structure model

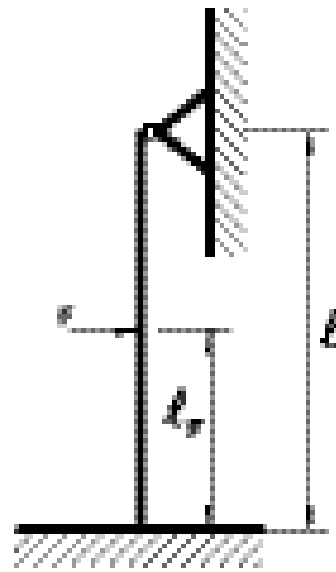


Table 9 : Coefficients  $\alpha, v$  (1/9/2003)

$A_F/A_W$	$\alpha$	$v$
0,0	1,50	0,0
0,20	1,23	0,44
0,40	1,16	0,62
0,60	1,11	0,71
0,80	1,09	0,76
1,00	1,07	0,80
1,20	1,06	0,83
1,40	1,05	0,85
1,60	1,05	0,87
1,80	1,04	0,88
2,00	1,04	0,89

**Note 1:**  
 $A_F$  : Cross-sectional area of the face plate,  
 $A_W$  : Cross-sectional area of the web.

## 6 Other structures

### 6.1 Application

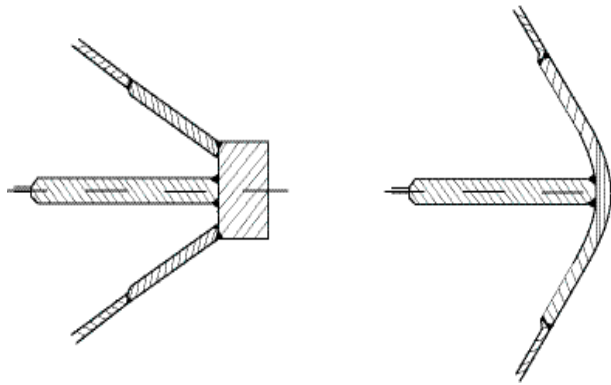
#### 6.1.1 (1/1/2001)

The requirements in [6.3] and [6.4] do not apply to the notation **ICE CLASS ID**.

### 6.2 Fore part

#### 6.2.1 Stem (1/1/2012)

The stem may be made of rolled, cast or forged steel or of shaped steel plates, as shown in Fig 5.

**Figure 5 : Example of suitable stems (1/1/2012)**

The plate thickness of a shaped plate stem and, in the case of a blunt bow, any part of the shell where  $\alpha \geq 30^\circ$  and  $\psi \geq 75^\circ$  ( $\alpha$  and  $\psi$  defined in Sec 1, [3.1.1]), is to be not less than that calculated in [5.1.2] assuming that:

- $s$  is the spacing of elements supporting the plate, in m
- $p_{PL}$ , in N/mm<sup>2</sup>, is taken equal to  $p$ , defined in [4.2.2], with  $\ell_a$  being the spacing of vertical supporting elements, in m.

The stem and the part of a blunt bow defined above are to be supported by floors or brackets spaced not more than 600 mm apart and having a thickness at least half that of the plate.

The reinforcement of the stem is to be extended from the keel to a point 0,75 m above the UIWL or, where an upper fore ice strengthened area is required (see [1.1.1]), to the upper limit of the latter.

### 6.2.2 Arrangements for towing (1/9/2003)

A mooring pipe with an opening not less than 250 mm by 300 mm, a length of at least 150 mm and an inner surface radius of at least 100 mm is to be fitted in the bow bulwark on the centreline.

A bitt or other means of securing a towline, dimensioned to withstand the breaking strength of the ship's towline, is to be fitted.

On ships with a displacement less than 30000 t, the part of the bow extending to a height of at least 5 m above the UIWL and at least 3 m back from the stem is to be strengthened to withstand the stresses caused by fork towing. For this purpose, intermediate ordinary stiffeners are to be fitted and the framing is to be supported by stringers or decks.

Note 1: It is to be noted that for ships of moderate size (displacement less than 30000 t), fork towing is, in many situations, the most efficient way of assisting in ice. Ships with a bulb protruding more than 2,5 m forward of the forward perpendicular are often difficult to tow in this way.

## 6.3 Aft part

### 6.3.1 (1/1/2012)

The minimum distance between propeller(s) and hull (including stern frame) is not to be less than  $h_c$  as defined in Sec 1, [2.3.1].

**6.3.2** On twin and triple screw ships, the ice strengthening of the shell and framing is to be extended to the double bottom for at least 1,5 m forward and aft of the side propellers.

**6.3.3** Shafting and sterntubes of side propellers are generally to be enclosed within plated bossings. If detached struts are used, their design, strength and attachment to the hull are to be examined by the Society on a case-by-case basis.

**6.3.4** A wide transom stern extending below the UIWL seriously impedes the capability of the ship to run astern in ice, which is of paramount importance.

Consequently, a transom stern is not normally to be extended below the UIWL. Where this cannot be avoided, the part of the transom below the UIWL is to be kept as narrow as possible.

The part of a transom stern situated within the ice strengthened area is to be strengthened as required for the midship region.

## 6.4 Deck strips and hatch covers

### 6.4.1 (1/1/2012)

Narrow deck strips abreast of hatches and serving as ice side girders are to comply with the section modulus and shear area calculated in [5.3.1] and [5.3.2], respectively. In the case of very long hatches, the product  $ph$  is to be taken less than 0,15 but in no case less than 0,10.

Special attention is to be paid when designing weather deck hatch covers and their fittings to the deflection of the ship sides due to ice pressure in way of very long hatch openings.

## 6.5 Sidescuttles and freeing ports

**6.5.1** Sidescuttles are not to be located in the ice strengthened area.

Special consideration is to be given to the design of freeing ports.

## 7 Hull outfitting

### 7.1 Rudders and steering arrangements

#### 7.1.1 (1/7/2020)

The scantlings of the rudder post, rudder stock, pintles, steering gear, etc. as well as the capacity of the steering gear are to be determined according to Pt B, Ch 10, Sec 1, taking the coefficient  $r_2$ , defined in Pt B, Ch 10, Sec 1, [2.1.2], equal to 1,10 irrespective of the rudder profile type.

However, the maximum ahead service speed of the ship to be used in these calculations is not to be taken less than that stated in Tab 10.

Where the actual maximum ahead service speed of the ship is higher than that stated in Tab 10, the higher speed is to be used.

The local scantlings of rudders are to be determined assuming that the whole rudder belongs to the ice strengthened area. Further, the rudder plating and frames are to be designed using the ice pressure  $p$  for the plating and frames in the midship region.



**Table 10 : Maximum ahead service speed (1/1/2001)**

Notation	Maximum ahead service speed (knots)
ICE CLASS IA SUPER	20
ICE CLASS IA	18
ICE CLASS IB	16
ICE CLASS IC ICE CLASS ID	14

**7.1.2 (1/1/2012)**

For the notations **ICE CLASS IA SUPER** or **ICE CLASS IA**, the rudder stock and the upper edge of the rudder are to be protected from direct contact with intact ice by an ice knife that extends below the LIWL, if practicable (or equivalent

means). Special consideration is to be given to the design of flap-type rudders.

**7.1.3 (1/1/2012)**

For the notations **ICE CLASS IA SUPER** or **ICE CLASS IA** suitable arrangements such as rudder stoppers are to be fitted to absorb large loads that arise when the rudder is forced out of the midship position while going astern in ice or into ice ridges.

**7.2 Bulwarks**

**7.2.1** If the weather deck in any part of the ship is situated below the upper limit of the ice strengthened area (e.g. in way of the well of a raised quarter deck), the bulwark is to be reinforced at least to the standard required for the shell in the ice strengthened area.

## SECTION 3

## MACHINERY

### 1 Propulsion

#### 1.1 Propulsion machinery performance

##### 1.1.1 (1/7/2020)

The engine output P is the total maximum output that the propulsion machinery can continuously deliver to the propeller. If the output of the machinery is restricted by technical means or by any regulations applicable to the ship, P is to be taken as the restricted output. In no case may P be less than the values calculated in accordance with Sec 1, [3.1.2] or Sec 1, [3.1.4], as applicable. If additional power sources are available for propulsion power (e.g. shaft motors), in addition to the power of the main engine(s), they are also to be included in the total engine output.

### 2 Class notations IAS, IA, IB and IC

#### 2.1 Propulsion machinery

##### 2.1.1 Scope (1/7/2020)

These requirements apply to propulsion machinery covering open- and ducted-type propellers with controllable pitch or fixed pitch design for the ice classes IAS, IA, IB and IC. The given loads are the expected ice loads throughout the ship's service life under normal operational conditions, including loads resulting from the changing rotational direction of FP propellers. However, these loads do not cover off-design operational conditions, for example when a stopped propeller is dragged through ice. The regulations also apply to azimuthing and fixed thrusters for main propulsion, considering loads resulting from propeller-ice interaction; the given azimuthing thruster body loads are the expected ice loads for the ship's service life under normal operational conditions. The local strength of the thruster body is to be sufficient to withstand local ice pressure when the thruster body is designed for extreme loads. However, the load models of the regulations do not include propeller/ice interaction loads when ice enters the propeller of a turned azimuthing thruster from the side (radially) or the load case when an ice block hits the propeller hub of a pulling propeller. Ice loads resulting from ice impacts on the body of thrusters are to be estimated, but ice load formulae are not available.

The thruster global vibrations caused by blade order excitation on the propeller may cause significant vibratory loads.

#### 2.2 Symbols

##### 2.2.1 (1/7/2020)

The symbols used in the formulae of this Section have the meaning indicated hereinafter. The loads considered are defined in Tab 1.

c : chord length of blade section, in m;

$c_{0,7}$	: chord length of blade section at 0,7R propeller radius, in m
CP	: controllable pitch
D	: propeller diameter, in m
d	: external diameter of propeller hub (at propeller plane), in m
$D_{limit}$	: limit value for propeller diameter, in m
EAR	: expanded blade area ratio;
$F_b$	: maximum backward blade force for the ship's service life, in kN;
$F_{ex}$	: ultimate blade load resulting from blade loss through plastic bending, in kN
$F_f$	: maximum forward blade force for the ship's service life, in kN
$F_{ice}$	: ice load, in kN
$(F_{ice})_{max}$	: maximum ice load for the ship's service life, in kN
FP	: fixed pitch
$h_0$	: depth of the propeller centreline from lower ice waterline, in m
$h_{ice}$	: thickness of maximum design ice block entering propeller, in m
I	: equivalent mass moment of inertia of all parts on engine side of component under consideration, in $kgm^2$
$I_t$	: equivalent mass moment of inertia of the whole propulsion system, in $kgm^2$
k	: shape parameter for Weibull distribution
LIWL	: lower ice waterline, in m
m	: slope for S-N curve in log/log scale, in kNm
$M_{BL}$	: blade bending moment
MCR	: maximum continuous rating
n	: propeller rotational speed, in rev./s
$n_n$	: nominal propeller rotational speed at MCR in free running condition, in rev./s
$N_{class}$	: reference number of impacts per propeller rotational speed per ice class
$N_{ice}$	: total number of ice loads on propeller blade for the ship's service life
$N_R$	: reference number of load for equivalent fatigue stress ( $10^8$ cycles)
$N_O$	: number of propeller revolutions during a milling sequence
$P_{0,7}$	: propeller pitch at 0,7R radius, in m
$P_{0,7n}$	: propeller pitch at 0,7R radius at MCR in free running condition, in m
$P_{0,7b}$	: propeller pitch at 0,7R radius at MCR in bollard condition, in m

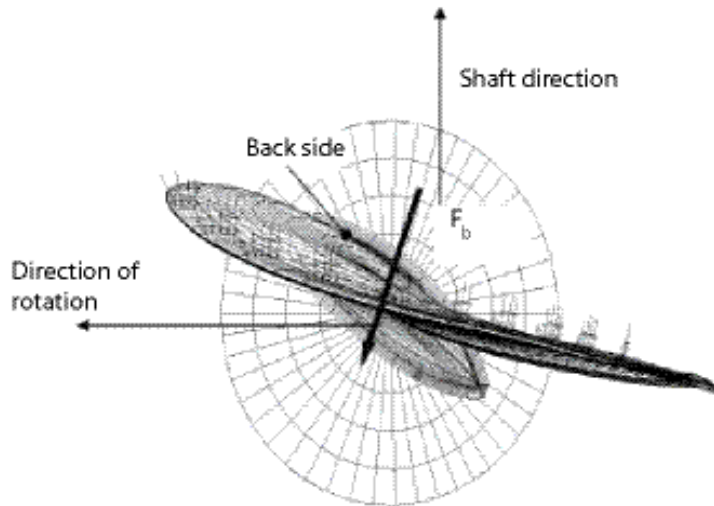
Q	: torque, in kNm	$\alpha_i$	: duration of propeller blade/ice interaction expressed in rotation angle, in [deg]
$Q_{emax}$	: maximum engine torque, in kNm	$\alpha_1$	: phase angle of propeller ice torque for blade order excitation component, in [deg]
$Q_{max}$	: maximum torque on the propeller resulting from propeller-ice interaction, in kNm	$\alpha_2$	: phase angle of propeller ice torque for twice the blade order excitation component, in [deg]
$Q_{max}^n$	: maximum torque on the propeller resulting from propeller/ice interaction reduced to the rotational speed in question, in kNm	$\gamma_e\gamma_{e1}$	: the reduction factor for fatigue; scatter effect
$Q_{motor}$	: electric motor peak torque, in kNm	$\gamma_{e2}$	: the reduction factor for fatigue; test specimen size effect
$Q_n$	: nominal torque at MCR in free running condition, in kNm	$\gamma_v$	: the reduction factor for fatigue; variable amplitude loading effect
$Q_r$	: maximum response torque along the propeller shaft line, in kNm	$\gamma_m$	: the reduction factor for fatigue; mean stress effect
$Q_{peak}$	: maximum of the response torque $Q_r$ , in kNm	$\rho$	: a reduction factor for fatigue correlating the maximum stress amplitude to the equivalent fatigue stress for $10^8$ stress cycles
$Q_{smax}$	: maximum spindle torque of the blade for the ship's service life, in kNm	$\sigma_{0,2}$	: proof yield strength of blade material, in MPa
$Q_{sex}$	: maximum spindle torque due to blade failure caused by plastic bending, in kNm	$\sigma_{exp}$	: mean fatigue strength of blade material at $10^8$ cycles to failure in sea water, in MPa
$Q_{vib}$	: vibratory torque at considered component, taken from frequency domain open water torque vibration calculation (TVC), in kNm	$\sigma_{fat}$	: equivalent fatigue ice load stress amplitude for $10^8$ stress cycles, in MPa
R	: propeller radius, in m	$\sigma_{fl}$	: characteristic fatigue strength for blade material, in MPa
r	: blade section radius, in m	$\sigma_{ref1}$	: reference stress $\sigma_{ref1} = 0,6 \cdot \sigma_{0,2} + 0,4 \cdot \sigma_u$ , in MPa
T	: propeller thrust, in kN	$\sigma_{ref2}$	: reference stress, in MPa $\sigma_{ref2} = 0,7 \cdot \sigma_u$ or $\sigma_{ref2} = 0,6 \cdot \sigma_{0,2} + 0,4 \cdot \sigma_u$ whichever is the lesser
$T_b$	: maximum backward propeller ice thrust for the ship's service life, in kN	$\sigma_{st}$	: maximum stress resulting from $F_b$ or $F_r$ , in MPa
$T_f$	: maximum forward propeller ice thrust for the ship's service life, in kN	$\sigma_u$	: ultimate tensile strength of blade material, in MPa
$T_n$	: propeller thrust at MCR in free running condition, in kN;	$(\sigma_{ice})_{bmax}$	: principal stress caused by the maximum backward propeller ice load, in MPa
$T_r$	: maximum response thrust along the shaft line, in kN	$(\sigma_{ice})_{fmax}$	: principal stress caused by the maximum forward propeller ice load, in MPa
t	: maximum blade section thickness, in m	$(\sigma_{ice})_{max}$	: maximum ice load stress amplitude, in MPa
Z	: number of propeller blades		

Table 1 : Definition of loads (1/7/2020)

	Definition	Use of the load in design process
$F_b$	The maximum lifetime backward force on a propeller blade resulting from propeller/ice interaction, including hydrodynamic loads on that blade. The direction of the force is perpendicular to 0,7R chord line. See Fig 1.	Design force for strength calculation of the propeller blade.
$F_f$	The maximum lifetime forward force on a propeller blade resulting from propeller/ice interaction, including hydrodynamic loads on that blade. The direction of the force is perpendicular to 0,7R chord line.	Design force for calculation of strength of the propeller blade.
$Q_{smax}$	The maximum lifetime spindle torque on a propeller blade resulting from propeller/ice interaction, including hydrodynamic loads on that blade.	In designing the propeller strength, the spindle torque is automatically taken into account because the propeller load is acting on the blade as distributed pressure on the leading edge or tip area.
$T_b$	The maximum lifetime thrust on propeller (all blades) resulting from propeller/ice interaction. The direction of the thrust is the propeller shaft direction and the force is opposite to the hydrodynamic thrust.	Is used for estimation of the response thrust $T_r$ . $T_b$ can be used as an estimate of excitation for axial vibration calculations. However, axial vibration calculations are not required in the Rules.

	Definition	Use of the load in design process
$T_f$	The maximum lifetime thrust on propeller (all blades) resulting from propeller/ice interaction. The direction of the thrust is the propeller shaft direction acting in the direction of hydrodynamic thrust.	Is used for estimation of the response thrust $T_r$ . $T_f$ can be used as an estimate of excitation for axial vibration calculations. However, axial vibration calculations are not required in the Rules.
$Q_{max}$	The maximum ice-induced torque resulting from propeller/ice interaction on one propeller blade, including hydrodynamic loads on that blade.	Is used for estimation of the response torque ( $Q_r$ ) along the propulsion shaft line and as excitation for torsional vibration calculations.
$F_{ex}$	Ultimate blade load resulting from blade loss through plastic bending. The force that is needed to cause total failure of the blade so that plastic hinge is caused to the root area. The force is acting on 0,8R. Spindle arm is to be taken as 2/3 of the distance between the axis of blade rotation and leading/trailing edge (whichever is the greater) at the 0,8R radius.	Blade failure load is used to dimension the blade bolts, pitch control mechanism, propeller shaft, propeller shaft bearing and thrust bearing. The objective is to guarantee that total propeller blade failure will not cause damage to other components.
$Q_r$	Maximum response torque along the propeller shaft line, taking into account the dynamic behaviour of the shaft line for ice excitation (torsional vibration) and hydrodynamic mean torque on the propeller.	Design torque for propeller shaft line components.
$T_r$	Maximum response thrust along shaft line, taking into account the dynamic behaviour of the shaft line for ice excitation (axial vibration) and hydrodynamic mean thrust on the propeller.	Design thrust for propeller shaft line components.
$F_{ti}$	Maximum response force caused by ice block impacts on the thruster body or the propeller hub.	Design load for thruster body and slewing bearings.
$F_{tr}$	Maximum response force on the thruster body caused by ice ridge/thruster body interaction.	Design load for thruster body and slewing bearings.

**Figure 1 : Direction of the backward blade force resultant taken perpendicular to chord line at radius 0,7R. Ice contact pressure at leading edge is shown with small arrows (1/1/2010)**



**2.3 Design ice conditions**

**2.3.1 (1/1/2010)**

In estimating the ice loads of the propeller for ice classes, different types of operation as given in Tab 2 are taken into account. For the estimation of design ice loads, a maximum ice block size is determined. The maximum design ice block entering the propeller is a rectangular ice block with the dimensions  $H_{ice}$   $2H_{ice}$   $3H_{ice}$ . The thickness of the ice block ( $H_{ice}$ ) is given in Tab 3.

**Table 2 (1/1/2010)**

Ice class	Operation of the ship
IA Super	Operation in ice channels and in level ice The ship may proceed by ramming
IA, IB, IC	Operation in ice channels

Table 3 (1/1/2010)

	IA Super	IA	IB	IC
Thickness of the design maximum ice block entering the propeller ( $H_{ice}$ )	1,75 m	1,5 m	1,2 m	1,0 m

## 2.4 Materials

### 2.4.1 Materials exposed to sea water (1/7/2020)

Materials of components exposed to sea water, such as propeller blades, propeller hubs, and thruster body, are to have an elongation of not less than 15% on a test specimen, the gauge length of which is five times the diameter. A Charpy V impact test is to be carried out for materials other than bronze and austenitic steel. An average impact energy value of 20 J taken from three tests is to be obtained at minus 10°C. For nodular cast iron, an average impact energy of 10 J at minus 10 °C is required accordingly.

### 2.4.2 Materials exposed to sea water temperature (1/7/2020)

Components exposed to sea water temperature are to be of ductile material. An average impact energy value of 20 J taken from three tests is to be obtained at minus 10 °C for materials other than bronze and austenitic steel. This requirement applies to the propeller shaft, blade bolts, CP mechanisms, shaft bolts, strut-pod connecting bolts etc. This does not apply to surface-hardened components, such as bearings and gear teeth. The nodular cast iron of a ferrite structure type may be used for relevant parts other than bolts. The average impact energy for nodular cast iron shall be a minimum of 10 J at minus 10 °C.

## 2.5 Design loads

### 2.5.1 (1/7/2020)

The given loads are intended for component strength calculations only and are total loads including ice-induced loads and hydrodynamic loads during propeller/ice interaction. The presented maximum loads are based on a worst case scenario that occurs once during the service life of the ship. Thus, the load level for a higher number of loads is lower.

The values of the parameters in the formulae in this section are to be given in the units shown in the symbol list.

If the propeller is not fully submerged when the ship is in ballast condition, the propulsion system is to be designed according to ice class IA for ice classes IB and IC.

### 2.5.2 Design loads on propeller blades (1/1/2010)

$F_b$  is the maximum force experienced during the lifetime of the ship that bends a propeller blade backwards when the propeller mills an ice block while rotating ahead.  $F_f$  is the maximum force experienced during the lifetime of the ship that bends a propeller blade forwards when the propeller mills an ice block while rotating ahead.  $F_b$  and  $F_f$  originate from different propeller/ice interaction phenomena, not acting simultaneously. Hence they are to be applied to one blade separately.

a) Maximum backward blade force  $F_b$  for open propellers

$$F_b = 27 \cdot [n \cdot D]^{0,7} \cdot \left[ \frac{EAR}{Z} \right]^{0,3} \cdot D^2 [\text{kN}], \text{ when } D \leq D_{limit}$$

$$F_b = 23 \cdot [n \cdot D]^{0,7} \cdot \left[ \frac{EAR}{Z} \right]^{0,3} \cdot D \cdot H_{ice}^{1,4} [\text{kN}], \text{ when } D > D_{limit}$$

where:

$$D_{limit} = 0,85 \cdot H_{ice}^{1,4} [\text{m}]$$

$n$  = is the nominal rotational speed (at MCR in free running condition) for a CP propeller and 85% of the nominal rotational speed (at MCR in free running condition) for an FP propeller.

b) Maximum forward blade force  $F_f$  for open propellers

$$F_f = 250 \cdot \left[ \frac{EAR}{Z} \right] \cdot D^2 [\text{kN}], \text{ when } D \leq D_{limit}$$

$$F_f = 500 \cdot \left[ \frac{EAR}{Z} \right] \cdot D \cdot \frac{1}{(1 - \frac{d}{D})} \cdot H_{ice} [\text{kN}], \text{ when } D > D_{limit}$$

where:

$$D_{limit} = \frac{2}{(1 - \frac{d}{D})} \cdot H_{ice} [\text{m}]$$

c) Loaded area on the blade for open propellers

Load cases 1-4 are to be covered, as given in Tab 4 below, for CP and FP propellers. In order to obtain blade ice loads for a reversing propeller, load case 5 is also to be covered for FP propellers.

d) Maximum backward blade ice force  $F_b$  for ducted propellers

$$F_b = 9,5 \cdot [n \cdot D]^{0,7} \cdot \left[ \frac{EAR}{Z} \right]^{0,3} \cdot D^2 [\text{kN}], \text{ when } D \leq D_{limit}$$

$$F_b = 66 [n \cdot D]^{0,7} \cdot \left[ \frac{EAR}{Z} \right]^{0,3} \cdot D^{0,6} \cdot H_{ice}^{1,4} [\text{kN}], \text{ when } D > D_{limit}$$

where:

$$D_{limit} = 4 \cdot H_{ice} [\text{m}]$$

$n$  = is the nominal rotational speed (at MCR in free running condition) for a CP propeller and 85% of the nominal rotational speed (at MCR in free running condition) for an FP propeller.

e) Maximum forward blade ice force  $F_f$  for ducted propellers

$$F_f = 250 \cdot \left[ \frac{EAR}{Z} \right] \cdot D^2 [\text{kN}], \text{ when } D \leq D_{limit}$$

$$F_f = 500 \cdot \left[ \frac{EAR}{Z} \right] \cdot D \cdot \frac{1}{(1 - \frac{d}{D})} \cdot H_{ice} [\text{kN}], \text{ when } D > D_{limit}$$

where:

$$D_{limit} = \frac{2}{\left(1 - \frac{d}{D}\right)} \cdot H_{ice} [m]$$

- f) Loaded area on the blade for ducted propellers  
Load cases 1 and 3 are to be covered as given in Tab 5 for all propellers, and an additional load case (load case 5) is to be considered for an FP propeller, to cover ice loads when the propeller is reversed.
- g) Maximum blade spindle torque  $Q_{smax}$  for open and ducted propellers

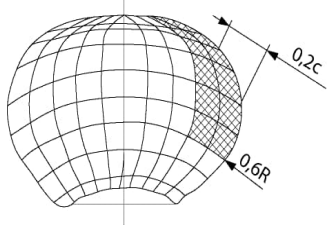
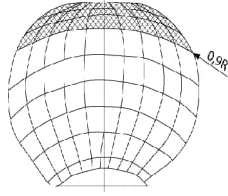
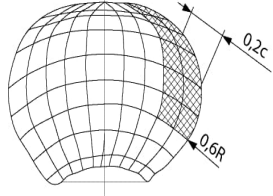
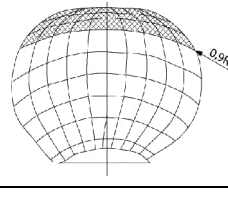
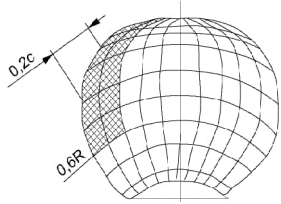
The spindle torque  $Q_{smax}$  around the axis of the blade fitting is to be determined both for the maximum backward blade force  $b_f$  and forward blade force  $f_f$ , which are applied as in Tab 4 and Tab 5.

If the above method gives a value which is less than the default value given by the formula below, the default value is to be used.

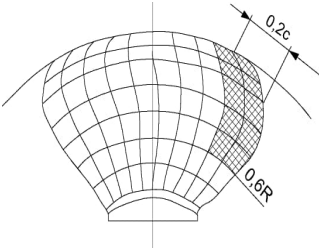
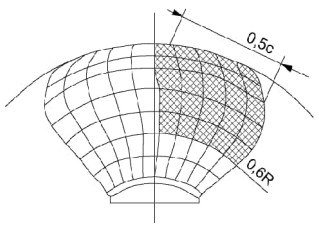
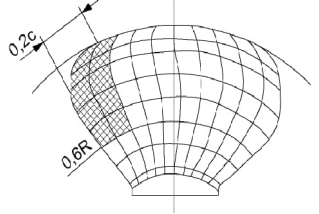
$$\text{Default value } Q_{smax} = 0,25 \cdot F \cdot c_{0,7} [kNm]$$

where  $c_{0,7}$  is the length of the blade section at 0,7R radius and F is either  $F_b$  or  $F_f$ , whichever has the greater absolute value.

**Table 4 : Load cases for open propellers (1/7/2020)**

	Force	Loaded area	Right handed propeller blade seen from behind
Load case 1	$F_b$	Uniform pressure applied on the back of the blade (suction side) to an area from 0,6R to the tip and from the leading edge to 0,2 times the chord length	
Load case 2	50% of $F_b$	Uniform pressure applied on the back of the blade (suction side) on the blade tip area outside of 0,9R radius	
Load case 3	$F_f$	Uniform pressure applied on the blade face (pressure side) to an area from 0,6R to the tip and from the leading edge to 0,2 times the chord length	
Load case 4	50% of $F_f$	Uniform pressure applied on the blade face (pressure side) of the blade tip area outside of 0,9R radius	
Load case 5	60 % of $F_f$ or $F_b$ , whichever is the greater	Uniform pressure applied on the blade face (pressure side) to an area from 0,6R to the tip and from the trailing edge to 0,2 times the chord length	

**Table 5 : Load cases for ducted propellers (1/7/2020)**

	Force	Loaded area	Right handed propeller blade seen from behind
Load case 1	$F_b$	Uniform pressure applied on the back of the blade (suction side) to an area from 0,6R to the tip and from the leading edge to 0,2 times the chord length	
Load case 3	$F_f$	Uniform pressure applied on the blade face (pressure side) to an area from 0,6R to the tip and from the leading edge to 0,5 times the chord length	
Load case 5	60 % of $F_f$ or $F_b$ , whichever is the greater	Uniform pressure applied on propeller face (pressure side) to an area from 0,6R to the tip and from blade the trailing edge to 0,2 times the chord length	

h) Load distributions for blade loads

The Weibull-type distribution (probability that  $F_{ice}$  exceeds  $(F_{ice})_{max}$ ), as given in Fig 2, is used for the fatigue design of the blade.

$$P\left(\frac{F_{ice}}{(F_{ice})_{max}} \geq \frac{F}{(F_{ice})_{max}}\right) = e^{-\left(\frac{F}{(F_{ice})_{max}}\right)^k \cdot \ln(N_{ice})}$$

where k is the shape parameter of the spectrum,  $N_{ice}$  is the number of load cycles in the spectrum, and  $F_{ice}$  is the random variable for ice loads on the blade,  $0 \leq F_{ice} \leq (F_{ice})_{max}$ . The shape parameter  $k=0,75$  is to be used for the ice force distribution of an open propeller and the shape parameter  $k=1,0$  for that of a ducted propeller blade.

i) Number of ice loads

The number of load cycles per propeller blade in the load spectrum is to be determined according to the formula:

$$N_{ice} = k_1 k_2 k_3 N_{class} n$$

where:

Reference number of loads for ice classes  $N_{class}$ , see Tab 6.

Propeller location factor  $k_1$ , see Tab 7.

Propulsion type factor  $k_3$ , see Tab 8.

**Table 6 (1/7/2020)**

Ice Class	IA Super	IA	IB	IC
impacts in life/n	$9 \cdot 10^6$	$6 \cdot 10^6$	$3,4 \cdot 10^6$	$2,1 \cdot 10^6$

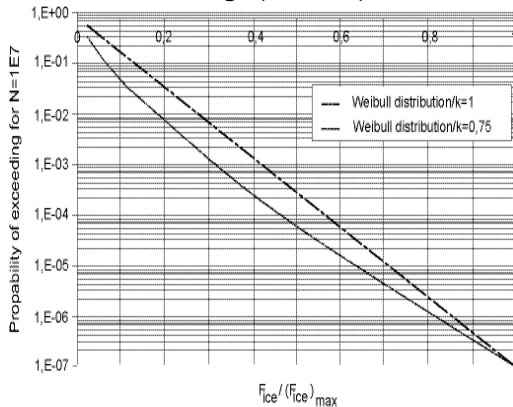
**Table 7 (1/7/2020)**

Centre propeller Bow first operation	Wing propeller Bow first operation	Pulling propeller (wing and centre) Bow propeller or Stern first operation
$k_1$	1	2
		3

**Table 8 (1/1/2010)**

type	fixed	azimuthing
$k_3$	1	1,2

**Figure 2 : The weibull-type distribution (probability that  $f_{ice}$  exceeds  $(f_{ice})_{max}$  that is used for fatigue design (1/1/2010)**



The submersion factor  $k_2$  is determined from the equation:

$$\begin{aligned}
 k_2 &= 0,8 - f && \text{when } f < 0 \\
 &= 0,8 - 0,4 \cdot f && \text{when } 0 \leq f \leq 1 \\
 &= 0,6 - 0,2 \cdot f && \text{when } 1 < f \leq 2,5 \\
 &= 0,1 && \text{when } f > 2,5
 \end{aligned}$$

where the immersion function  $f$  is:

$$f = \frac{h_0 - H_{ice}}{D/2} - 1$$

where  $h_0$  is the depth of the propeller centreline at the lower ice waterline (LIWL) of the ship.

For components that are subject to loads resulting from propeller/ice interaction with all the propeller blades, the number of load cycles ( $N_{ice}$ ) is to be multiplied by the number of propeller blades ( $Z$ ).

**2.5.3 Axial design loads for open and ducted propellers (1/1/2010)**

- a) Maximum ice thrust on propeller  $T_f$  and  $T_b$  for open and ducted propellers

The maximum forward and backward ice thrusts are:

$$\begin{aligned}
 T_f &= 1,1 \cdot F_f \text{ [kN]} \\
 T_b &= 1,1 \cdot F_b \text{ [kN]}
 \end{aligned}$$

- b) Design thrust along the propulsion shaft line for open and ducted propellers

The design thrust along the propeller shaft line is to be calculated with the formulae below. The greater value of the forward and backward direction loads is to be taken as the design load for both directions. The factors 2,2 and 1,5 take into account the dynamic magnification resulting from axial vibration.

In a forward direction:

$$T_r = T + 2,2 \cdot T_f \text{ [kN]}$$

In a backward direction:

$$T_r = 1,5 \cdot T_b \text{ [kN]}$$

If the hydrodynamic bollard thrust,  $T$ , is not known,  $T$  is to be taken as indicated in Tab 9.

**Table 9 (1/1/2010)**

Propeller type	T
CP propellers (open)	1,25 $T_n$
CP propellers (ducted)	1,1 $T_n$
FP propellers driven by turbine or electric motor	$T_n$
FP propellers driven by diesel engine (open)	0,85 $T_n$
FP propellers driven by diesel engine (ducted)	0,75 $T_n$

Here,  $T_n$  is the nominal propeller thrust at MCR in free running open water condition.

**2.5.4 Torsional design loads (1/7/2020)**

- a) Design ice torque on propeller  $Q_{max}$  for open propellers  
 $Q_{max}$  is the maximum torque on a propeller resulting from ice/propeller interaction during the service life of the ship.

$$Q_{max} = 10,9 \left[ 1 - \frac{d}{D} \right] \left[ \frac{P_{0,7}}{D} \right]^{0,16} (nD)^{0,17} D^3 \text{ [kNm]}$$

when  $D \leq D_{limit}$

$$Q_{max} = 20,7 \left[ 1 - \frac{d}{D} \right] \left[ \frac{P_{0,7}}{D} \right]^{0,16} (nD)^{0,17} D^{1,9} H_{ice}^{1,1} \text{ [kNm]}$$

when  $D > D_{limit}$

where

$$D_{limit} = 1,8 \cdot H_{ice} \text{ [m]}$$

$n$  is the rotational propeller speed at MCR in bollard condition. If not known,  $n$  is to be taken as indicated in Tab 10.

**Table 10 (1/1/2010)**

Propeller type	Rotational speed $n$
CP propellers	$n_n$
FP propellers driven by turbine or electric motor	$n_n$
FP propellers driven by diesel engine	0,85 $n_n$

Here,  $n_n$  is the nominal rotational speed at MCR in the free running open water condition.

For CP propellers, the propeller pitch  $P_{0,7}$  is to correspond to MCR in bollard condition. If not known,  $P_{0,7}$  is to be taken as  $0,7 \cdot P_{0,7n}$ , where  $P_{0,7n}$  is the propeller pitch at MCR in free running condition.

- b) Design ice torque on propeller  $Q_{max}$  for ducted propellers

$Q_{max}$  is the maximum torque on a propeller during the service life of the ship resulting from ice/propeller interaction.



$$Q_{max} = 7,7 \left[ 1 - \frac{d}{D} \right] \left[ \frac{P_{0,7}}{D} \right]^{0,16} (nD)^{0,17} D^3 [\text{kNm}]$$

when  $D \leq D_{limit}$

$$Q_{max} = 14,6 \left[ 1 - \frac{d}{D} \right] \left[ \frac{P_{0,7}}{D} \right]^{0,16} (nD)^{0,17} D^{1,9} H^{1,1} H_{ice} [\text{kNm}]$$

when  $D > D_{limit}$   
where:

$$D_{limit} = 1,8 \cdot H_{ice} [\text{m}]$$

$n$  is the rotational propeller speed at MCR in bollard condition. If not known,  $n$  is to be taken as indicated in Tab 11.

**Table 11 (1/1/2010)**

Propeller type	Rotational speed $n$
CP propellers	$n_n$
FP propellers driven by turbine or electric motor	$n_n$
FP propellers driven by diesel engine	$0,85 n_n$

Here,  $n_n$  is the nominal rotational speed at MCR in free running condition.

For CP propellers, the propeller pitch  $P_{0,7}$  is to correspond to MCR in bollard condition. If not known,  $P_{0,7}$  is to be taken as  $0,7 \cdot P_{0,7n}$ , where  $P_{0,7n}$  is the propeller pitch at MCR in free running condition.

c) Design torque for non resonant shaft lines

If there is not any relevant first blade order torsional resonance within the designed operating rotational speed range extended 20% above the maximum and 20% below the minimum operating speeds, the following estimation of the maximum torque can be used.

- For directly coupled two stroke diesel engines without flexible coupling:

$$Q_{peak} = Q_{emax} + Q_{vjb} + Q_{max} \cdot I / I_t [\text{kNm}],$$

- For other plants:

$$Q_{peak} = Q_{emax} + Q_{max} \cdot I / I_t [\text{kNm}]$$

where  $I$  is the equivalent mass moment of inertia of all parts on the engine side of the component under consideration and  $I_t$  is the equivalent mass moment of inertia of the whole propulsion system.

All the torques and the inertia moments are to be reduced to the rotation speed of the component being examined.

If the maximum torque,  $Q_{emax}$ , is not known, it is to be taken as indicated in Tab 12.

Here,  $Q_{motor}$  is the electric motor peak torque.

d) Design torque for shaft lines having resonances

If there is a first blade order torsional resonance within the designed operating rotational speed range extended 20% above the maximum and 20% below the minimum operating speeds, the design torque ( $Q_{peak}$ ) of the shaft component is to be determined by means of torsional vibration analysis of the propulsion line. The following

two alternatives ways of performing the dynamic analysis are accepted:

- 1) time domain calculation for estimated milling sequence excitation; or
- 2) frequency domain calculation for blade orders sinusoidal excitation

The frequency domain analysis is generally considered conservative compared to the time domain simulation, provided that there is a first blade order resonance in the considered speed range.

**Table 12 (1/1/2010)**

Propeller type	$Q_{emax}$
Propellers driven by electric motor	$Q_{motor}$
CP propellers not driven by electric motor	$Q_n$
FP propellers driven by turbine	$Q_n$
FP propellers driven by diesel engine	$0,75 Q_n$

e) Time domain calculation of torsional response

Time domain calculations is to be calculated for the MCR condition, MCR bollard conditions and for blade order resonant rotational speeds so that the resonant vibration responses can be obtained.

The load sequence described below, for a case where a propeller is milling an ice block, is to be used for the strength evaluation of the propulsion line. The given load sequence is not intended for propulsion system stalling analyses.

The following load cases are intended to reflect the operational loads on the propulsion system, when the propeller interacts with ice, and the respective reaction of the complete system. The ice impact and system response causes loads in the individual shaft line components. The ice torque  $Q_{max}$  may be taken as a constant value in the complete speed range. When considerations at specific shaft speeds are performed, a relevant  $Q_{max}$  may be calculated using the relevant speed according to [2.5.4].

Diesel engine plants without an elastic coupling are to be calculated at the least favourable phase angle for ice versus engine excitation, when calculated in the time domain. The engine firing pulses are to be included in the calculations and their standard steady state harmonics can be used.

If there is a blade order resonance just above the MCR speed, calculations are to cover rotational speeds up to 105% of the MCR speed.

The propeller ice torque excitation for shaft line transient dynamic analysis in the time domain is defined as a sequence of blade impacts which are of half sine shape. The excitation frequency is to follow the propeller rotational speed during the ice interaction sequence. The torque due to a single blade ice impact as a function of the propeller rotation angle is then defined using the formula:

$$Q(\varphi) = C_q \cdot Q_{max} \cdot \sin(\varphi(180/\alpha_i)), \text{ when } \varphi = 0 \dots \alpha_i$$

$$Q(\varphi) = 0, \text{ when } \varphi = \alpha_i \dots 360$$

Where

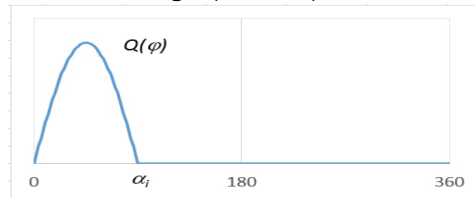
$\varphi$  is the rotation angle from when the first impact occurs and parameters  $C_q$  and  $\alpha_i$  are given in Tab 13.

$\alpha_i$  is the duration of propeller blade/ice interaction expressed in terms of the propeller rotation angle. See Fig 3.

**Table 13 (1/7/2020)**

Torque excitation	Propelled/ice interaction	$C_q$	$\alpha_i$ Z=3	$\alpha_i$ Z=4	$\alpha_i$ Z=5	$\alpha_i$ Z=6
Case 1	Single ice block	0,75	90	90	72	60
Case 2	Single ice block	1,0	135	135	135	135
Case 3	Two ice block (phase shift 360/2/Z deg.)	0,5	45	45	36	30
Case 4	Single ice block	0,5	45	45	36	30

**Figure 3 : Schematic ice torque due to a single blade ice impact as a function of the propeller rotation angle (1/7/2020)**



The total ice torque is obtained by summing the torque of single blades, while taking account of the phase shift 360 deg./Z, see Fig 4 and Fig 5. At the beginning and end of the milling sequence (within the calculated duration) linear ramp functions are to be used to increase  $C_q$  to its maximum value within one propeller revolution and vice versa to decrease it to zero (see the examples of different Z numbers in Fig 4 and Fig 5).

The number of propeller revolutions during a milling sequence are to be obtained from the formula:

$$N_Q = 2 \cdot H_{ice}$$

The number of impacts is  $Z \cdot N_Q$  for blade order excitation. An illustration of all excitation cases for different blade numbers is given in Fig 4 and Fig 5.

A dynamic simulation is to be performed for all excitation cases at the operational rotational speed range. For a fixed pitch propeller propulsion plant, a dynamic simulation is to also cover the bollard pull condition with a corresponding rotational speed assuming the maximum possible output of the engine.

If a speed drop occurs until the main engine is at a stand-still, this indicates that the engine may not be sufficiently powered for the intended service task. For the consideration of loads, the maximum occurring torque during the speed drop process is to be used.

Figure 4 : The shape of the propeller ice torque excitation sequences for propellers with 3 and 4 blades (1/7/2020)

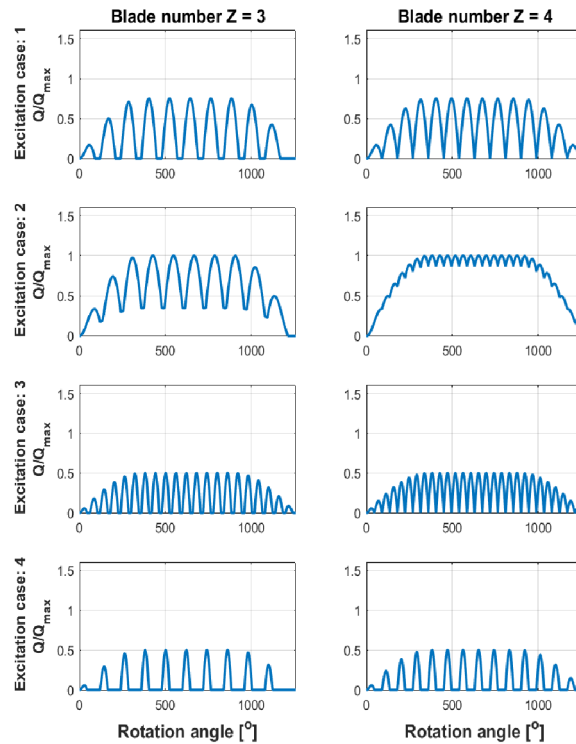
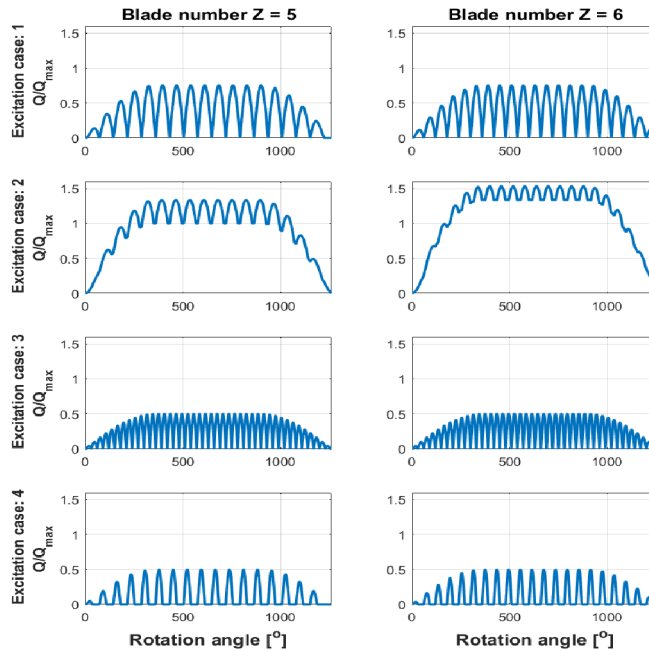


Figure 5 : The shape of the propeller ice torque excitation sequences for propellers with 5 and 6 blades (1/7/2020)



For the time domain calculation, the simulated response torque typically includes the engine mean torque and the propeller mean torque. If this is not the case, the response torques must be obtained using the formula:

$$Q_{\text{peak}} = Q_{\text{emax}} + Q_{\text{rtd}}$$

Where  $Q_{\text{rtd}}$  is the maximum simulated torque obtained from the time domain analysis.

- f) Frequency domain calculation of torsional response.  
For frequency domain calculations, blade order and twice-the-blade-order excitation may be used. The amplitudes for the blade order and twice-the-blade-order sinusoidal excitation have been derived based on the assumption that the time domain half sine impact sequences were continuous, and the Fourier series components for blade order and twice-the-blade-order com-

ponents have been derived. The propeller ice torque is then:

$$Q_F(\varphi) = Q_{\max} \cdot (C_{q0} + C_{q1} \cdot \sin(Z \cdot E_0 \cdot \varphi + \alpha_1) + C_{q2} \cdot \sin(2 \cdot Z \cdot E_0 \cdot \varphi + \alpha_2)) \text{ [kNm]}$$

Where:

$C_{q0}$  is mean torque parameter

$C_{q1}$  is the first blade order excitation parameter

$C_{q2}$  is the second blade order excitation parameter

$\alpha_1, \alpha_2$  are phase angles of the excitation component

$\varphi$  is the angle of rotation

$E_0$  is the number of ice blocks in contact

The values of the parameters are given in Tab 14

**Table 14 (1/7/2020)**

Torque excitation	$C_{q0}$	$C_{q1}$	$\alpha_1$	$C_{q2}$	$\alpha_2$	$E_0$
Torque Excitation: Z = 3						
Case 1	0,375	0,36	-90	0	0	1
Case 2	0,7	0,33	-90	0,05	-45	1
Case 3	0,25	0,25	-90	0		2
Case 4	0,2	0,25	0	0,05	-90	1
Torque Excitation: Z = 4						
Case 1	0,45	0,36	-90	0,06	-90	1
Case 2	0,9375	0	-90	0,0625	-90	1
Case 3	0,25	0,25	-90	0	0	2
Case 4	0,2	0,25	0	0,05	-90	1
Torque Excitation: Z = 5						
Case 1	0,45	0,36	-90	0,06	-90	1
Case 2	1,19	0,17	-90	0,02	-90	1
Case 3	0,3	0,25	-90	0,048	-90	2
Case 4	0,2	0,25	0	0,05	-90	1
Torque Excitation: Z = 6						
Case 1	0,45	0,36	90	0,05	-90	1
Case 2	1,435	0,1	90	0	0	1
Case 3	0,3	0,25	90	0,048	-90	2
Case 4	0,2	0,25	0	0,05	-90	1

The design torque for the frequency domain excitation case is to be obtained using the formula:

$$Q_{\text{peak}} = Q_{\text{emax}} + Q_{\text{vib}} + (Q_{\text{max}}^n \cdot C_{q0}) \cdot l_e/l_t + Q_{\text{rf1}} + Q_{\text{rf2}}$$

Where:

$Q_{\text{max}}^n$  is the maximum propeller ice torque at the operation speed in consideration

$C_{q0}$  is the mean static torque coefficient from Tab 14

$Q_{\text{rf1}}$  is the blade order torsional response from the frequency domain analysis

$Q_{\text{rf2}}$  is the second order blade torsional response from the frequency domain analysis

If the prime mover maximum torque,  $Q_{\text{emax}}$ , is not known, it is to be taken as given in Tab 12. All the torque values have to be scaled to the shaft revolutions for the component in question.

g) Guidance for torsional vibration calculation

The aim of time domain torsional vibration simulations is to estimate the extreme torsional load for the ship's lifespan. The simulation model can be taken from the normal lumped mass elastic torsional vibration model, including damping. For a time domain analysis, the model should include the ice excitation at the propeller, other relevant excitations and the mean torques provided by the prime mover and hydrodynamic mean torque in the propeller. The calculations should cover variation of phase between the ice excitation and prime mover excitation. This is extremely relevant to propulsion lines with directly driven combustion engines. Time domain calculations are to be calculated for the MCR condition, MCR bollard conditions and for resonant speed, so that the resonant vibration responses can be obtained.

For frequency domain calculations, the load should be estimated as a Fourier component analysis of the continuous sequence of half sine load sequences. First and second order blade components should be used for excitation.

The calculation should cover the entire relevant rpm range and the simulation of responses at torsional vibration resonances.

**2.5.5 Blade failure load (1/7/2020)**

The ultimate load resulting from blade failure as a result of plastic bending around the blade root is to be calculated with the formula below or alternatively by means of an appropriate stress analysis, reflecting the non-linear plastic material behaviour of the actual blade. In such a case, the blade failure area may be outside the root section. The ultimate load is assumed to be acting on the blade at the 0,8R radius in the weakest direction of the blade. A blade is regarded as having failed if the tip is bent into an offset position by more than 10% of propeller diameter D.

$$F_{\text{ex}} = \frac{300 \cdot c \cdot t^2 \cdot \sigma_{\text{ref}}}{0,8 \cdot D - 2 \cdot r} \text{ [kN]}$$

where

$$\sigma_{\text{ref}} = 0,6 \cdot \sigma_{0,2} + 0,4 \cdot \sigma_u$$

$\sigma_u$  minimum ultimate tensile strength, to be specified on the drawing; and

$\sigma_{0,2}$  minimum yield or 0.2% proof strength to be specified on the drawing

c, t, and r are, respectively, the length, thickness, and radius of the cylindrical root section of the blade at the weakest section outside the root fillet.

**2.5.6 Spindle Torque,  $Q_{sex}$  (1/7/2020)**

The maximum spindle torque due to a blade failure load acting at 0.8R is to be determined. The force that causes blade failure typically reduces when moving from the propeller centre towards the leading and trailing edges. At a certain distance from the blade centre of rotation, the maximum spindle torque will occur. This maximum spindle torque is to be defined by an appropriate stress analysis or using the equation given below.

$$Q_{sex} = \max(C_{LE0,8}; 0,8 \cdot C_{TE0,8}) \cdot C_{spex} \cdot F_{ex} \text{ [kNm]}$$

where

$$C_{spex} = C_{sp} \cdot C_{fex} = 0,7 \cdot \left(1 - \left(\frac{4 \cdot EAR}{Z}\right)^3\right)$$

$C_{sp}$  is a non-dimensional parameter taking account of the spindle arm

$C_{fex}$  is a non-dimensional parameter taking account of the reduction of the blade failure force at the location of the maximum spindle torque.

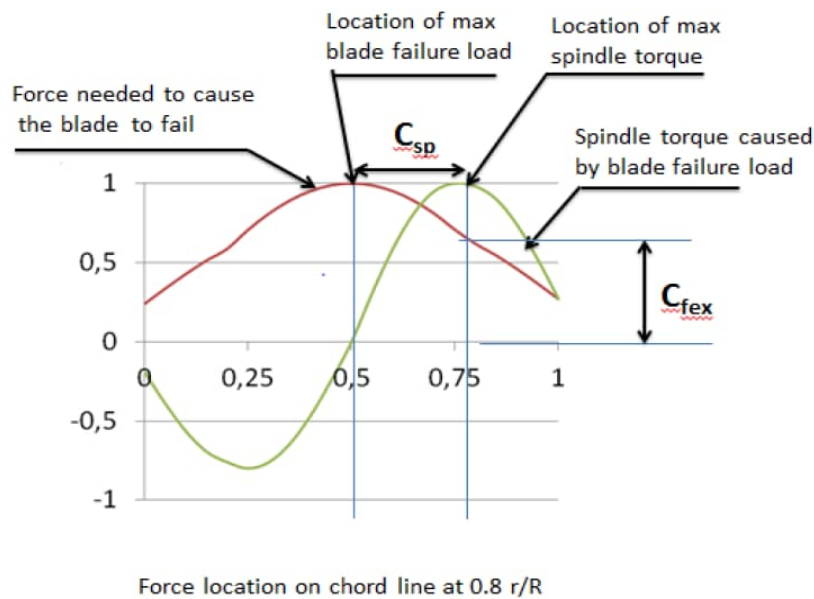
If  $C_{spex}$  is below 0,3, a value of 0,3 is to be used for  $C_{spex}$

$C_{LE0,8}$  is the leading edge portion of the chord length at 0.8R

$C_{TE0,8}$  is the trailing edge portion of the chord length at 0.8R

Fig 6 illustrates the spindle torque values due to blade failure loads across the entire chord length.

**Figure 6 : Schematic figure showing a blade failure load and the related spindle torque when the force acts at a different location on the chord line at radius 0.8R. (1/7/2020)**



**2.6 Design**

**2.6.1 Design principle (1/1/2010)**

The strength of the propulsion line is to be designed according to the pyramid strength principle.

This means that the loss of the propeller blade is not to cause any significant damage to other propeller shaft line components.

**2.6.2 Propeller blade (1/4/2021)**

a) Calculation of blade stresses

The blade stresses are to be calculated for the design loads given in [2.5.2]. Finite element analysis is to be used for stress analysis for final approval for all propellers. When this analysis is carried out by the Designer, it is to be submitted to the Society. The following simpli-

fied formulae can be used in estimating the blade stresses for all propellers at the root area ( $r/R < 0,5$ ). The root area dimensions based on the following formula can be accepted even if the FEM analysis would show greater stresses at the root area.

$$\sigma_{st} = C_1 \frac{M_{BL}}{100 \cdot ct^2} \text{ [MPa]}$$

where

constant  $C_1$  is the  $\frac{\text{actual stress}}{\text{stress obtained with beam equation}}$

If the actual value is not available,  $C_1$  is to be taken as 1,6.

$M_{BL} = (0,75 - r/R) \cdot R \cdot F$ , for relative radius  $r/R < 0,5$

$F$  is the maximum of  $F_b$  and  $F_r$ , whichever is greater.

b) Acceptability criterion

The following criterion for calculated blade stresses is to be fulfilled.

$$(\sigma_{ref2} / \sigma_{st}) \geq 1,5$$

where:

$\sigma_{st}$  is the calculated stress for the design loads. If FEM analysis is used in estimating the stresses, von Mises stresses are to be used.

$\sigma_{ref2}$  is the reference stress, defined as:

$$\sigma_{ref2} = 0,7 \cdot \sigma_u \quad \text{or}$$

$$\sigma_{ref2} = 0,6 \cdot \sigma_{0,2} + 0,4 \cdot \sigma_u, \quad \text{whichever is the lesser.}$$

c) Fatigue design of propeller blade

The fatigue design of the propeller blade is based on an estimated load distribution for the service life of the ship and the S-N curve for the blade material. An equivalent stress that produces the same fatigue damage as the expected load distribution is to be calculated and the acceptability criterion for fatigue is to be fulfilled as given in this section. The equivalent stress is normalised for 100 million cycles.

For material with a two-slope F-N curve if the following criterion is fulfilled, fatigue calculations according to this chapter are not required.

$$\sigma_{exp} \geq B_1 \cdot \sigma_{ref2}^{B_2} \cdot \log(N_{ice})^{B_3}$$

where  $B_1$ ,  $B_2$  and  $B_3$  coefficients for open and ducted propellers are given in Tab 15.

An alternative approach may be accepted by the Society on a case-by-case basis, if deemed equivalent based on the information provided by the manufacturer.

**Table 15 (1/4/2021)**

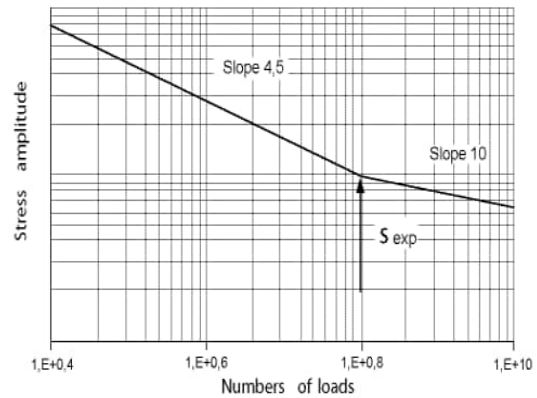
	Open propeller	Ducted propeller
$B_1$	0,00328	0,00223
$B_2$	1,0076	1,0071
$B_3$	2,101	2,471

For calculation of equivalent stress, two types of S-N curves are available.

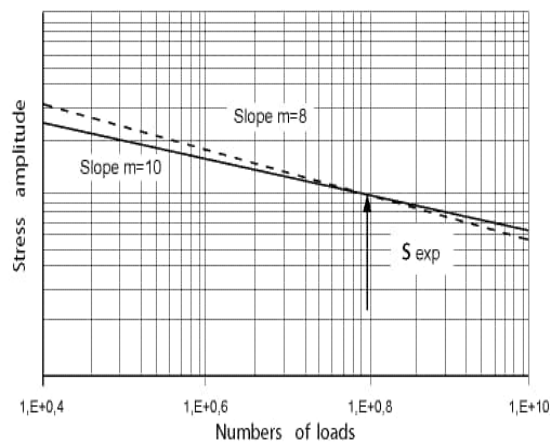
- 1) Two-slope S-N curve (slopes 4.5 and 10) (see Fig 7).
- 2) One-slope S-N curve (the slope can be chosen) (see Fig 8).

The type of the S-N curve is to be selected to correspond to the material properties of the blade. If the S-N curve is not known, the two-slope S-N curve is to be used.

**Figure 7 : Two-slope S-N curve (1/1/2010)**



**Figure 8 : Constant-slope S-N curve (1/1/2010)**



d) Equivalent fatigue stress:

the equivalent fatigue stress for 100 million stress cycles which produces the same fatigue damage as the load distribution is:

$$\sigma_{fat} = \rho \cdot (\sigma_{ice})_{max}$$

where:

$$(\sigma_{ice})_{max} = 0,5 ((\sigma_{ice})_{f max} - (\sigma_{ice})_{b max})$$

$(\sigma_{ice})_{max}$  is the mean value of the principal stress amplitudes resulting from design forward and backward blade forces at the location being studied

$(\sigma_{ice})_{f max}$  is the principal stress resulting from forward load

$(\sigma_{ice})_{b max}$  is the principal stress resulting from backward load.

In calculation of  $(\sigma_{ice})_{max}$ , case 1 and case 3 (or case 2 and case 4) are considered as a pair for  $(\sigma_{ice})_{f max}$  and  $(\sigma_{ice})_{b max}$  calculations. Case 5 is excluded from the fatigue analysis.

e) Calculation of  $\rho$  parameter for two-slope S-N curve:

The parameter  $\rho$  relates the maximum ice load to the distribution of ice loads according to the regression formulae.

$$\rho = C_1 \cdot (\sigma_{ice})_{max}^{C_2} \cdot \sigma_{fl}^{C_3} \cdot \log(N_{ice})^{C_4}$$

where:

$$\sigma_{fl} = \gamma_e \cdot \gamma_v \cdot \gamma_m \cdot \sigma_{exp}$$

$$\sigma_{fl} = \gamma_{e1} \cdot \gamma_{e2} \cdot \gamma_v \cdot \gamma_m \cdot \sigma_{exp}$$

where:

$\gamma_{e1}$  is the reduction factor for due to scatter and test specimen size effect (equal to one standard deviation)

$\gamma_{e2}$  is the reduction factor for test specimen size effect

$\gamma_v$  is the reduction factor for variable amplitude loading

$\gamma_m$  is the reduction factor for mean stress

$\sigma_{exp}$  is the mean fatigue strength of the blade material at  $10^8$  cycles to failure in sea water.

The following values are to be used for the reduction factors if actual values are not available:

$$\gamma_e = \gamma_{e1} \cdot \gamma_{e2} = 0,67, \gamma_v = 0,75, \text{ and } \gamma_m = 0,75.$$

The coefficients  $C_1, C_2, C_3$ , and  $C_4$  are given in Tab 16.

The applicable range of  $N_{ice}$  for calculating  $\rho$  is  $5 \times 10^6 \leq N_{ice} \leq 10^8$ .

**Table 16 (1/7/2020)**

	Open propeller	Ducted propeller
$C_1$	0,000747	0,000534
$C_2$	0,0645	0,0533
$C_3$	-0,0565	-0,0459
$C_4$	2,22	2,584

f) Calculation of  $\rho$  parameter for constant-slope S-N curve:

for materials with a constant-slope S-N curve - see Fig 8 Fig 8 - the  $\rho$  factor is to be calculated with the following formula:

$$\rho = \left( G \frac{N_{ice}}{N_R} \right)^{1/m} (\ln(N_{ice}))^{-1/k}$$

where:

$k$  is the shape parameter of the Weibull distribution  $k = 1,0$  for ducted propellers and  $k = 0,75$  for open propellers.  $N_R$  is the reference number of load cycles (=100 million).

The applicable range of  $N_{ice}$  for calculating  $\rho$  is  $5 \times 10^6 \leq N_{ice} \leq 10^8$ .

Values for the  $G$  parameter are given in Tab 17. Linear interpolation may be used to calculate the  $G$  value for other  $m/k$  ratios than those given in Tab 17.

**Table 17 : : Value for the G parameter for different m/k ratios (1/7/2020)**

m/k	G	m/k	G	m/k	G	m/k	G
3	6	5,5	287,9	8	40320	10,5	11,899E6
3,5	11,6	6	720	8,5	119292	11	39,917E6

m/k	G	m/k	G	m/k	G	m/k	G
4	24	6,5	1871	9	362880	11,5	136,843E6
4,5	52,3	7	5040	9,5	1,133E6	12	479,002E6
5	120	7,5	14034	10	3,623E6		

g) Acceptability criterion for fatigue

The equivalent fatigue stress at all locations on the blade is to fulfil the following acceptability criterion:

$$\frac{\sigma_{fl}}{\sigma_{fat}} \geq 1,5$$

where

$$\sigma_{fl} = \gamma_{e1} \cdot \gamma_{e2} \cdot \gamma_v \cdot \gamma_m \cdot \sigma_{exp}$$

$\gamma_{e1}$  is the reduction factor due to scatter (equal to one standard deviation)

$\gamma_{e2}$  is the reduction factor for test specimen size effect

$\gamma_v$  is the reduction factor for variable amplitude loading

$\gamma_m$  is the reduction factor for mean stress

$\sigma_{exp}$  is the mean fatigue strength of the blade material at  $10^8$  cycles to failure in sea water.

The following values are to be used for the reduction factors if actual values are not available:

$$\gamma_e = \gamma_{e1} \cdot \gamma_{e2} = 0,67, \gamma_v = 0,75, \text{ and } \gamma_m = 0,75.$$

**2.6.3 Propeller bossing and CP mechanism (1/1/2010)**

The blade bolts, the CP mechanism, the propeller boss, and the fitting of the propeller to the propeller shaft are to be designed to withstand the maximum and fatigue design loads, as defined in [2.5]. The safety factor against yielding is to be greater than 1,3 and that against fatigue greater than 1,5. In addition, the safety factor for loads resulting from loss of the propeller blade through plastic bending as defined in [2.5.5] is to be greater than 1,0 against yielding.

**2.6.4 Propulsion shaft line (1/7/2020)**

a) General

The shafts and shafting components, such as the thrust and sterntube bearings, couplings, flanges and sealings, are to be designed to withstand the propeller/ice interaction loads as given in [2.5]. The safety factor is to be at least 1,3 against yielding for extreme operational loads, 1,5 for fatigue loads and 1,0 against yielding for the blade failure load.

b) Shafts and shafting components

The ultimate load resulting from total blade failure as defined in [2.5.5] is not to cause yielding in shafts and shaft components. The loading is to consist of the combined axial, bending and torsion loads, wherever this is significant. The minimum safety factor against yielding is to be 1,0 for bending and torsional stresses.

### 2.6.5 Azimuthing main propulsors (1/7/2020)

#### a) Design principle

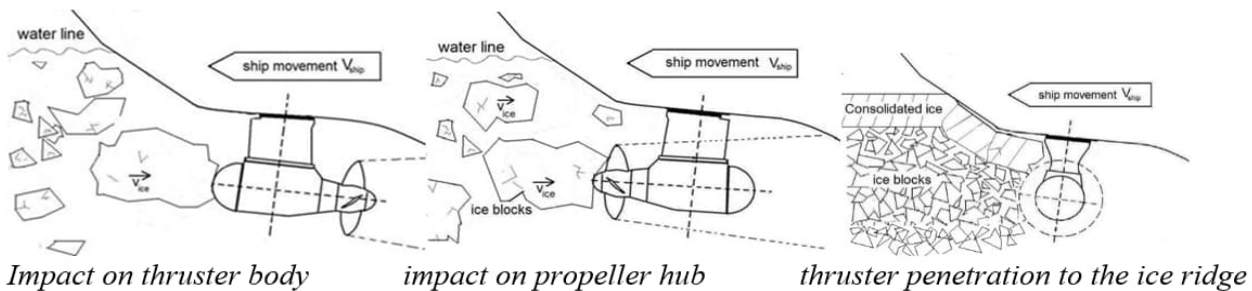
In addition to the above requirements, special consideration is to be given to those loading cases which are extraordinary for propulsion units when compared with conventional propellers. The estimation of loading cases is to reflect the way of operation of the ship and the thrusters. In this respect, for example, the loads caused by the impacts of ice blocks on the propeller hub of a pulling propeller are to be considered. Furthermore, loads resulting from the thrusters operating at an oblique angle to the flow are to be considered for propeller blade dimensioning, azimuthing thrusters are to be designed for thruster body/ice interaction loads. Load formulae are given for estimating once in a lifetime extreme loads on the thruster body, based on the estimated ice condition and ship operational parameters. Two main ice load scenarios have been selected for defining the extreme ice loads. Examples of loads are illustrated in Fig 9. In addition, blade order thruster body vibration responses are to be estimated for propeller excitation. The following load scenario types are considered: The steering mechanism, the fitting of the

unit, and the body of the thruster are to be designed to withstand the loss of a blade without damage. The loss of a blade is to be considered for the propeller blade orientation which causes the maximum load on the component being studied. Typically, top-down blade orientation places the maximum bending loads on the thruster body.

- 1) Ice block impact on the thruster body or propeller hub
- 2) Thruster penetration into an ice ridge that has a thick consolidated layer
- 3) Vibratory response of the thruster at blade order frequency

The steering mechanism, the fitting of the unit, and the body of the thruster are to be designed to withstand the loss of a blade without damage. The loss of a blade is to be considered for the propeller blade orientation which causes the maximum load on the component being studied. Typically, top-down blade orientation places the maximum bending loads on the thruster body.

**Figure 9 : Examples of load scenario types (1/7/2020)**



#### b) Extreme ice impact loads

When the ship is operated in ice conditions, ice blocks formed in channel side walls or from the ridge consolidated layer may impact on the thruster body and the propeller hub. Exposure to ice impact is very much dependent on the ship size and ship hull design, as well as the location of the thruster. The contact force will grow in terms of thruster/ice contact until the ice block reaches the ship speed.

The thruster must withstand the loads occurring when the design ice block defined in Tab 3 impacts on the thruster body when the ship is sailing at a typical ice operating speed. Load cases for impact loads are given in Tab 18. The contact geometry is estimated to be hemispherical in shape. If the actual contact geometry differs from the shape of the hemisphere, a sphere radius must be estimated so that the growth of the contact area as a function of penetration of ice corresponds as closely as possible to the actual geometrical shape penetration.



**Table 18 : Load cases for azimuthing thruster ice impact loads (1/7/2020)**

	Force	Loaded area	
Load case T1a Symmetric longitudinal ice impact on thruster	$F_{ti}$	Uniform pressure applied symmetrically on the impact area	
Load case T1b Non-symmetric longitudinal ice impact on thruster	50% of $F_{ti}$	Uniform pressure applied on the other half of the impact area.	
Load case T1c Non-symmetric longitudinal ice impact on nozzle	$F_{ti}$	Uniform pressure applied on the impact area. Contact area is equal to the nozzle thickness ( $H_{nz}$ )*the contact height ( $H_{ice}$ )	
Load case T2a Symmetric longitudinal ice impact on propeller hub	$F_{ti}$	Uniform pressure applied symmetrically on the impact area.	

	Force	Loaded area	
Load case T2b Non-symmetric longitudinal ice impact on propeller hub	50% of $F_{ti}$	Uniform pressure applied on the other half of the impact area.	
Load case T3a Symmetric lateral ice impact on thruster body	$F_{ti}$	Uniform pressure applied symmetrically on the impact area.	
Load case T3b Non-symmetric lateral ice impact on thruster body or nozzle	$F_{ti}$	Uniform pressure applied on the impact area. Nozzle contact radius R to be taken from the nozzle length ( $L_{nz}$ )	

The ice impact contact load is to be calculated using the below formula. The related parameter values are given in Tab 19. The design operation speed in ice is to be derived from Tab 20 and Tab 21, or the ship in question's actual design operation speed in ice can be used. The longitudinal impact speed in Tab 20 and Tab 21 refers to the impact in the thruster's main operational direction. For the pulling propeller configuration, the longitudinal impact speed is used for load case T2,

impact on hub; and for the pushing propeller unit, the longitudinal impact speed is used for load case T1, impact on thruster end cap. For the opposite direction, the impact speed for transversal impact is applied.

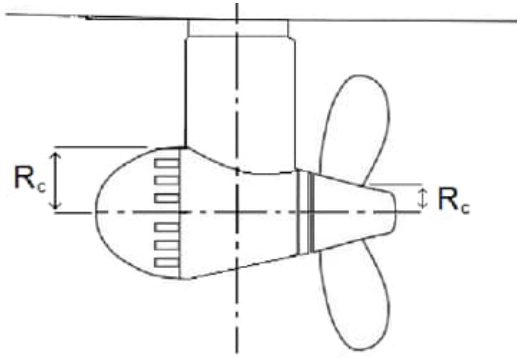
$$F_{ti} = C_{DMI} \cdot 34,5 \cdot R_c^{0,5} \cdot (m_{ice} \cdot v_s^2)^{0,333} \quad [\text{KN}]$$

Where:

- $R_c$  is the impacting part sphere radius, in m, see Fig 10

- $m_{ice}$  is the ice block mass, in Kg
- $v_s$  is the ship speed, in m/s, at the time of contact
- $C_{DMI}$  is the dynamic magnification factor for impact loads to be taken from Tab 19, if unknown.

**Figure 10 : Dimensions used for  $R_c$  (1/7/2020)**



For impacts on non-hemispherical areas, such as the impact on the nozzle, the equivalent impact sphere radius is to be estimated using the equation below.

$$R_{ceq} = \sqrt{\frac{A}{\pi}} \quad [m]$$

If the  $2 \cdot R_{ceq}$  is greater than the ice block thickness, the radius is set to half of the ice block thickness. For the impact on the thruster side, the pod body diameter can be used as a basis for determining the radius. For the impact on the propeller hub, the hub diameter can be used as a basis for the radius.

**Table 19: Parameter values for ice dimensions and dynamic magnification (1/7/2020)**

	IA Super	IA	IB	IC
Thickness of the design ice block impacting thruster (2/3 of $H_{ice}$ )	1,17 m	1,0 m	0,8 m	0,67 m
Extreme ice block mass ( $m_{ice}$ )	8670 kg	5460 kg	2800 kg	1600 kg
$C_{DMI}$ (if not known)	1,3	1,2	1,1	1

**Table 20 : Impact speeds for aft centerline thruster (1/7/2020)**

Aft centreline thruster				
Longitudinal impact in main operational direction	6 m/s	5 m/s	5 m/s	5 m/s
Longitudinal impact in reversing direction (pushing unit propeller hub or pulling unit cover end cap impact)	4 m/s	3 m/s	3 m/s	3 m/s
Transversal impact in bow first operation	3 m/s	2 m/s	2 m/s	2 m/s
Transversal impact in stern first operation (double acting ship)	4 m/s	3 m/s	3 m/s	3 m/s

**Table 21: Impact speeds for aft wing, bow centerline and bow wing thrusters (1/7/2020)**

Aft wing, bow centreline and bow wing thruster				
Longitudinal impact in main operational direction	6 m/s	5 m/s	5 m/s	5 m/s
Longitudinal impact in reversing direction (pushing unit propeller hub or pulling unit cover end cap impact)	4 m/s	3 m/s	3 m/s	3 m/s
Transversal impact	4 m/s	3 m/s	3 m/s	3 m/s

- c) Extreme ice loads on thruster hull when penetrating an ice ridge

In icy conditions, ships typically operate in ice channels. When passing other ships, ships may be subject to loads caused by their thrusters penetrating ice channel walls. There is usually a consolidated layer at the ice surface, below which the ice blocks are loose. In addition, the thruster may penetrate ice ridges when backing. Such a situation is likely in the case of IA Super ships in particular, because they may sail independently in difficult ice conditions. However, the thrusters in ships with lower ice classes may also have to withstand such a situation, but at a remarkably lower ship speed.

In this load scenario, the ship is penetrating a ridge in thruster first mode with an initial speed. This situation occurs when a ship with a thruster at the bow moves forward, or a ship with a thruster astern moves in backing mode. The maximum load during such an event is considered the extreme load. An event of this kind typically lasts several seconds, due to which the dynamic magnification is considered negligible and is not taken into account.

The load magnitude is to be estimated for the load cases shown in Tab 22, using the below equation. The parameter values for calculations are given in Tab 23 and Tab 24. The loads are to be applied as uniform pressure over the thruster surface. The design operation speed in ice can be derived from Tab 23 and Tab 24. Alternatively, the actual design operation speed in ice of the ship in question can be used.

$$F_{tr} = 32 \cdot v_s^{0,66} \cdot H_r^{0,9} \cdot A_t^{0,74} \text{ [KN]}$$

Where:

- $v_s$  is the ship speed, in m/s
- $H_r$  is design ridge thickness (the thickness of the consolidated layer is 18% of the total ridge thickness), in m.
- $A_t$  is the projected area of the thruster, in  $m^2$

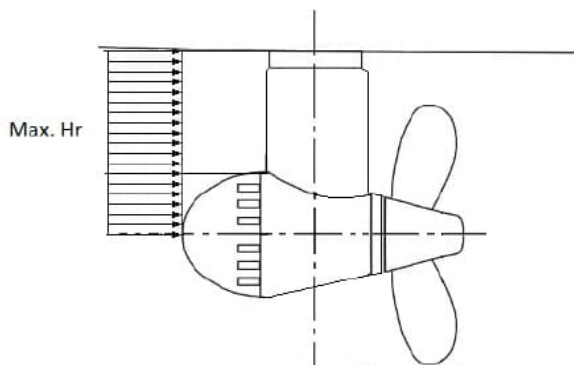
**Table 22 : Load cases for ridge ice loads (1/7/2020)**

	Force	Loaded area	
Load case T4a Symmetric longitudinal ridge penetration loads	$F_{tr}$	Uniform pressure applied symmetrically on the impact area.	
Load case T4b Non-symmetric longitudinal ridge penetration loads	50% of $F_{tr}$	Uniform pressure applied on the other half of the contact area.	

	Force	Loaded area	
Load case T4b Non-symmetric longitudinal ridge penetration loads	$F_{tr}$	Uniform pressure applied symmetrically on the contact area.	
Load case T5b Non-symmetric lateral ridge penetration loads for all azimuthing units	50% of $F_{tr}$	Uniform pressure applied on the other half of the contact area.	

When calculating the contact area for thruster-ridge interaction, the loaded area in the vertical direction is limited to the ice ridge thickness, as shown in Fig 11.

**Figure 11 : Schematic figure showing the reduction of the contact area by the maximum ridge thickness (1/7/2020)**



**Table 23 Parameters for calculating maximum loads when the thruster penetrates an ice ridge. Aft thrusters. Bow first operation (1/7/2020)**

	IA Super	IA	IB	IC
Thickness of the design ridge consolidated layer	1,5 m	1,5 m	1,2 m	1,0 m
Total thickness of the design ridge, $H_r$	8 m	8 m	6,5 m	5 m
Initial ridge penetration speed (longitudinal loads)	4 m/s	2 m/s	2 m/s	2 m/s
Initial ridge penetration speed (transversal loads)	2 m/s	1 m/s	1 m/s	1 m/s

**Table 24 Parameters for calculating maximum loads when the thruster penetrates an ice ridge. Thruster first mode such as double acting ships. (1/7/2020)**

	IA Super	IA	IB	IC
Thickness of the design ridge consolidated layer	1,5 m	1,5 m	1,2 m	1,0 m
Total thickness of the design ridge, $H_r$	8 m	8 m	6,5 m	5 m
Initial ridge penetration speed (longitudinal loads)	6 m/s	4 m/s	4 m/s	4 m/s
Initial ridge penetration speed (transversal loads)	3 m/s	2 m/s	2 m/s	2 m/s

d) Acceptability criterion for static loads

The stresses on the thruster are to be calculated for the extreme once in a lifetime loads described in [2.6.5]. The nominal von Mises stresses on the thruster body is to have a safety margin of 1,3 against the yielding strength of the material. At areas of local stress concentrations, stresses are to have a safety margin of 1,0 against yielding. The slewing bearing, bolt connections and other components are to be able to maintain operability without incurring damage that requires repair when subject to the loads given in [2.6.5] b) and c) multiplied by a safety factor of 1,3.

e) Thruster body global vibration

Evaluating the global vibratory behaviour of the thruster body is important, if the first blade order excitations are in the same frequency range with the thruster global modes of vibration, which occur when the propeller rotational speeds are in the high power range of the propulsion line. This evaluation is mandatory and it must be shown that there is either no global first blade order resonance at high operational propeller speeds (above 50% of maximum power) or that the structure is designed to withstand vibratory loads during resonance above 50% of maximum power.

When estimating thruster global natural frequencies in the longitudinal and transverse direction, the damping and added mass due to water must be taken into account. In addition to this, the effect of ship attachment stiffness is to be modelled.

### 2.6.6 Vibrations (1/1/2010)

The propulsion system is to be designed in such a way that the complete dynamic system is free from harmful torsional, axial, and bending resonances at a 1-order blade frequency within the designed running speed range, extended by 20 per cent above and below the maximum and minimum operating rotational speeds. If this condition cannot be fulfilled, a detailed vibration analysis is to be carried out in order to determine that the acceptable strength of the components can be achieved.

## 2.7 Alternative design procedure

### 2.7.1 Scope (1/1/2010)

As an alternative to [2.5] and [2.6], a comprehensive design study may be carried out to the satisfaction of the Society. The study is to be based on ice conditions given for the different ice classes in [2.3]. It is to include both fatigue and maximum load design calculations and fulfil the pyramid strength principle, as given in [2.6.1].

### 2.7.2 Loading (1/1/2010)

Loads on the propeller blade and propulsion system are to be based on an acceptable estimation of hydrodynamic and ice loads.

### 2.7.3 Design levels (1/7/2020)

The analysis is to indicate that all components transmitting random (occasional) forces, excluding the propeller blade, are not subjected to stress levels in excess of the yield stress of the component material, with a reasonable safety margin.

Cumulative fatigue damage calculations are to indicate a reasonable safety factor. Due account is to be taken of material properties, stress raisers, and fatigue enhancements.

Vibration analysis is to be carried out and is to indicate that the overall dynamic system is free from harmful torsional resonances resulting from propeller/ice interaction.

## 2.8 Starting arrangements for propulsion machinery

**2.8.1** In addition to complying with the provisions of Pt C, Ch 1, Sec 10, [17.3], ships with the ice class notation IAS are to have air starting compressors capable of charging the air receivers in half an hour, where their propulsion engines need to be reversed in order to go astern.

## 3 Class notation ID

### 3.1 Ice torque

#### 3.1.1 (1/1/2010)

For the scantlings of propellers, shafting and reverse and/or reduction gearing, the effect of the impact of the propeller blades against ice is also to be taken into account.

The ensuing torque, hereafter defined as ice torque, is to be taken equal to the value  $M_G$ , in N m, calculated by the following formula:

$$M_G = 11000 D^2$$

where:

D is the propeller diameter, in m.

### 3.2 Propellers

#### 3.2.1 Material (1/1/2010)

Materials of propellers are to have an elongation of not less than 15% on a test specimen, the gauge length of which is five times the diameter. A Charpy V impact test is to be carried out for materials other than bronze and austenitic steel. An average impact energy value of 20 J taken from three tests is to be obtained at minus 10 °C.

**3.2.2 Scantlings (1/1/2010)**

The width  $l$  and the maximum thickness  $t$  of the cylindrical sections of the propeller blades are to be such as to satisfy the conditions stated in a), b) and c) below.

- a) Cylindrical sections at the radius of  $0,125D$ ,  
for fixed pitch propellers

$$l \cdot t^2 \geq \frac{26,5}{R_m \cdot \left[0,65 + \left(\frac{0,7}{\rho}\right)\right]} \cdot \left(\frac{2,85M_T}{z} + 2,24M_G\right)$$

- b) Cylindrical sections at the radius of  $0,175D$   
for controllable pitch propellers

$$l \cdot t^2 \geq \frac{21,1}{R_m \cdot \left[0,65 + \left(\frac{0,7}{\rho}\right)\right]} \cdot \left(\frac{2,85M_T}{z} + 2,35M_G\right)$$

- c) Cylindrical sections at the radius of  $0,3D$   
both for fixed and controllable pitch propellers

$$l \cdot t^2 \geq \frac{9,3}{R_m \cdot \left[0,65 + \left(\frac{0,7}{\rho}\right)\right]} \cdot \left(\frac{2,85M_T}{z} + 2,86M_G\right)$$

where:

- $l$  : width of the expanded cylindrical section of the blade at the radius in question, in cm;  
 $t$  : corresponding maximum blade thickness, in cm;  
 $\rho$  :  $D/H$ ;  
 $D$  : propeller diameter, in m;  
 $H$  : blade pitch of propeller, in m, to be taken equal to:
  - the pitch at the radius considered, for fixed pitch propellers,
  - 70% of the nominal pitch, for controllable pitch propellers; $P$  : maximum continuous power of propulsion machinery for which the class notation has been requested, in kW;  
 $n$  : speed of rotation of propeller, in rev/min, corresponding to the power  $P$ ;  
 $t$  : value, in Nm, of torque corresponding to the above power  $P$  and speed  $n$ , calculated as follows:  
 $M_T = 9550 \cdot P/n$   
 $z$  : number of propeller blades;  
 $M_G$  : value, in Nm, of the ice torque, calculated according to the formula given in [3.1.1];  
 $R_m$  : value, in N/mm<sup>2</sup>, of the minimum tensile strength of the blade material.;

**3.2.3 Minimum thickness of blades (1/1/2010)**

When the blade thicknesses, calculated by the formulae given in Pt C, Ch 1, Sec 8, [2.2.1] and Pt C, Ch 1, Sec 8, [2.3.1], are higher than those calculated on the basis of the formulae given in [3.2.2], the higher values are to be taken as Rule blade thickness.

**3.2.4 Minimum thickness at top of blade (1/1/2010)**

The blade tip thickness at the radius  $0,5 D$  is not to be less than the value  $t_1$ , in mm, obtained by the following formula:

$$t_1 = (15 + 2D) \cdot (490 / R_m)^{0,5}$$

In the formula above,  $D$  and  $R_m$  have the same meaning as specified in [3.2.2].

**3.2.5 Blade thickness at intermediate sections (1/1/2010)**

The thickness of the other sections of the blade is to be determined by means of a smooth curve connecting the points defined by the blade thicknesses calculated by the formulae given in [3.2.2] and [3.2.4].

**3.2.6 Thickness of blade edge (1/1/2010)**

The thickness of the whole blade edge, measured at a distance from the edge itself equal to  $1,25 t_1$  ( $t_1$  being the blade thickness as calculated by the appropriate formula given in [3.2.4]), is to be not less than  $0,5 t_1$ .

For controllable pitch propellers, this requirement is applicable to the leading edge only.

**3.2.7 Controllable pitch propeller actuating mechanism (1/1/2010)**

The strength of the blade-actuating mechanism located inside the controllable pitch propeller hub is to be not less than 1,5 times that of the blade when a force is applied at the radius  $0,45 D$  in the weakest direction of the blade.

**3.3 Shafting****3.3.1 Propeller shafts (1/1/2010)**

- a) Propeller shafts are to be of steel having impact strength as specified in Pt D, Ch 2, Sec 3, [3.6.4]
- b) The diameter of the propeller shaft at its aft bearing is not to be less than the value calculated according to Pt C, Ch 1, Sec 7, [2.2.3] increased by 5%.

**3.3.2 Intermediate shafts (1/1/2010)**

No Rule diameter increase of intermediate and thrust shafts is generally required.

**4 Miscellaneous requirements****4.1 Sea inlets and cooling water systems of machinery****4.1.1 (1/9/2003)**

- a) The cooling water system is to be designed to ensure the supply of cooling water also when navigating in ice.
- b) For this purpose, for ships with the notation **IAS**, **IA**, **IB** or **IC**, at least one sea water inlet chest is to be arranged and constructed as indicated hereafter:
  - 1) The sea inlet is to be situated near the centreline of the ship and as aft as possible.
  - 2) As guidance for design, the volume of the chest is to be about one cubic metre for every 750 kW of the aggregate output of the engines installed on board, for both main propulsion and essential auxiliary services.

- 3) The chest is to be sufficiently high to allow ice to accumulate above the inlet pipe.
- 4) A pipe for discharging the cooling water, having the same diameter as the main overboard discharge line, is to be connected to the inlet chest.
- 5) The area of the strum holes is to be not less than 4 times the inlet pipe sectional area.

For ships with the notation **ID**, at least one of the largest sea water inlet chests is to be connected with the cooling water discharge by a pipe having the same diameter as the overboard discharge line. In addition, the arrangement of a bottom sea water inlet, situated as aft as possible, is recommended.

- c) Where there are difficulties in satisfying the requirements of b) 2) and b) 3) above, two smaller chests may be arranged for alternating intake and discharge of cooling water.
- d) Heating coils may be installed in the upper part of the chests.
- e) Arrangements for using ballast water for cooling purposes may be accepted as a reserve in ballast conditions but are not acceptable as a substitute for the sea inlet chests as described above.

## **4.2 Systems to prevent ballast water from freezing**

### **4.2.1 (1/7/2007)**

Any ballast tank situated above the LIWL, as defined in Sec 1, [2.1.1] b), and needed to load down the ship to this waterline is to be equipped with devices to prevent the water from freezing.

## **4.3 Steering gear**

### **4.3.1 (1/7/2020)**

- a) In the case of ships with the ice class notations **IAS** and **IA**, due regard is to be paid to the excessive loads caused by the rudder being forced out of the centreline position when backing into an ice ridge.
- b) Effective relief valves are to be provided to protect the steering gear against hydraulic overpressure.
- c) The scantlings of steering gear components are to be such as to withstand a torque causing yield of the required diameter rudder stock.
- d) Where possible, rudder stoppers working on the blade or rudder head are to be fitted.

## **4.4 Fire pumps**

### **4.4.1 (1/1/2010)**

The suction of at least one fire pump is to be connected to a sea inlet protected against icing.



Part F  
**Additional Class Notations**

Chapter 10  
**POLAR CLASS (POLAR)**

---

- SECTION 1      GENERAL**
- SECTION 2      HULL**
- SECTION 3      MACHINERY**



# SECTION 1

# GENERAL

## 1 General

### 1.1 Application

#### 1.1.1 (1/7/2017)

The following additional class notations are assigned in accordance with Pt A, Ch 1, Sec 2, [6.10] to ships constructed of steel and intended for independent navigation in ice-infested polar waters:

- POLAR CLASS PC1
- POLAR CLASS PC2
- POLAR CLASS PC3
- POLAR CLASS PC4
- POLAR CLASS PC5
- POLAR CLASS PC6
- POLAR CLASS PC7

#### 1.1.2 (1/7/2017)

For the purpose of this Chapter, the notations mentioned in [1.1.1] are indicated using the following abbreviations:

- PC1 for POLAR CLASS PC1
- PC2 for POLAR CLASS PC2
- PC3 for POLAR CLASS PC3
- PC4 for POLAR CLASS PC4
- PC5 for POLAR CLASS PC5
- PC6 for POLAR CLASS PC6
- PC7 for POLAR CLASS PC7

Ships that comply with Sec 2 and Sec 3 are assigned one of the additional class notations **POLAR CLASS** as listed in Tab 1.

The provisions of Sec 2 and Sec 3 are in addition to other applicable requirements of the Rules.

If the hull and machinery are constructed such as to comply with the requirements of different **POLAR CLASS** notations, then both the hull and machinery are to be assigned the lower of these classes on the Certificate of Classification. Compliance of the hull or machinery with the requirements of a higher **POLAR CLASS** is also to be indicated on the Certificate of Classification or equivalent.

#### 1.1.3 (1/7/2017)

Ships which are assigned a **POLAR CLASS** notation and complying with the relevant provisions of Sec 2 and Sec 3 may be given the additional notation "Icebreaker".

"Icebreaker" refers to any ship with an operational profile that includes escort or ice management functions, having

powering and dimensions that allow it to undertake aggressive operations in ice-covered waters.

#### 1.1.4 (1/7/2017)

For ships which are assigned a **POLAR CLASS** notation, the hull form and propulsion power are to be such that the ship can operate independently and at continuous speed in a representative ice condition, as defined in Tab 1 for the corresponding Polar Class. For ships and ship-shaped units which are intentionally not designed to operate independently in ice, such operational intent or limitations are to be explicitly stated in the Certificate of Classification or equivalent.

#### 1.1.5 (1/7/2017)

For ships which are assigned a **POLAR CLASS** notation **PC 1** through **PC 5**, bows with vertical sides, and bulbous bows are generally to be avoided. Bow angles should in general be within the range specified in Sec 2, [4.1.5].

#### 1.1.6 (1/7/2017)

For ships which are assigned a **POLAR CLASS** notation **PC 6** and **PC 7**, and are designed with a bow with vertical sides or bulbous bows, operational limitations (restricted from intentional ramming) in design conditions are to be stated in the Certificate of Classification or equivalent.

#### 1.1.7 (1/3/2008)

The **POLAR CLASS (PC)** notations and descriptions are given in Tab 1. It is the responsibility of the Owner to select an appropriate Polar Class.

## 2 Ice waterlines

### 2.1 Definitions

#### 2.1.1 Upper ice waterline (1/3/2008)

The upper ice waterline (UIWL) is defined by the maximum draughts fore, amidships and aft.

#### 2.1.2 Lower ice waterline (1/7/2017)

The lower ice waterline (LIWL) is defined by the minimum draughts fore, amidships and aft.

The lower ice waterline is to be determined with due regard to the ship's ice-going capability in the ballast loading conditions. The propeller is to be fully submerged at the lower ice waterline (LIWL).

**Table 1 : Polar Class descriptions (1/3/2008)**

Polar Class	Ice description (based on WMO (1) Sea Ice Nomenclature)
PC1	Year-round operation in all polar waters
PC2	Year-round operation in moderate multi-year ice conditions
PC3	Year-round operation in second-year ice which may include multi-year ice inclusions
PC4	Year-round operation in thick first-year ice which may include old ice inclusions
PC5	Year-round operation in medium first-year ice which may include old ice inclusions
PC6	Summer/autumn operation in medium first-year ice which may include old ice inclusions
PC7	Summer/autumn operation in thin first-year ice which may include old ice inclusions
(1) WMO: World Meteorological Organisation	

## 2.2 Indication of upper and lower ice waterlines

### 2.2.1 (1/3/2008)

The upper and lower ice waterlines upon which the design of the ship is based are to be specified by the Designer in the plans submitted for approval to the Society and are to be stated on the Certificate of Classification.

## SECTION 2

## HULL

### 1 General

#### 1.1 Definitions

##### 1.1.1 (1/1/2021)

The length  $L_{UI}$  is the distance, in m, measured horizontally from the fore side of the stem at the intersection with the upper ice waterline (UIWL) to the after side of the rudder post, or the centre of the rudder stock if there is no rudder post.  $L_{UI}$  is not to be less than 96%, and need not be greater than 97%, of the extreme length of the upper ice waterline (UIWL) measured horizontally from the fore side of the stem. In ships with unusual stern and bow arrangement the length  $L_{UI}$  will be specially considered.

##### 1.1.2 (1/1/2021)

The ship displacement  $\Delta_{UI}$  is the displacement, in t, of the ship corresponding to the upper ice waterline (UIWL). Where multiple waterlines are used for determining the UIWL, the displacement is to be determined from the waterline corresponding to the greatest displacement.

#### 1.2 Hull areas

##### 1.2.1 (1/3/2008)

The hull of all Polar Class ships is divided into areas reflecting the magnitude of the loads that are expected to act upon them. In the longitudinal direction, there are four regions:

- Bow,
- Bow Intermediate,
- Midbody,
- Stern.

The Bow Intermediate, Midbody and Stern regions are further divided in the vertical direction into the following regions:

- Bottom,

- Lower,
- Icebelt.

The extent of each hull area is indicated in Fig 1, where  $x$ , in m, measured at the aft end of the Bow region, in m, is to be taken as:

- 1,5 for **PC1 to PC4**
- 1,0 for **PC5 to PC7**

The upper ice waterline (UIWL) and lower ice waterline (LIWL) are as defined in Sec 1.

##### 1.2.2 (1/3/2008)

Fig 1 notwithstanding, at no time is the boundary between the Bow and Bow Intermediate regions to be forward of the intersection point of the line of the stem and the ship baseline.

##### 1.2.3 (1/1/2021)

Fig 1 notwithstanding, the aft boundary of the Bow region need not be more than 0,45  $L_{UI}$  aft of the fore side of the stem at the intersection with the upper ice waterline (UIWL).

##### 1.2.4 (1/3/2008)

The boundary between the bottom and lower regions is to be taken at the point where the shell is inclined 7 deg from horizontal.

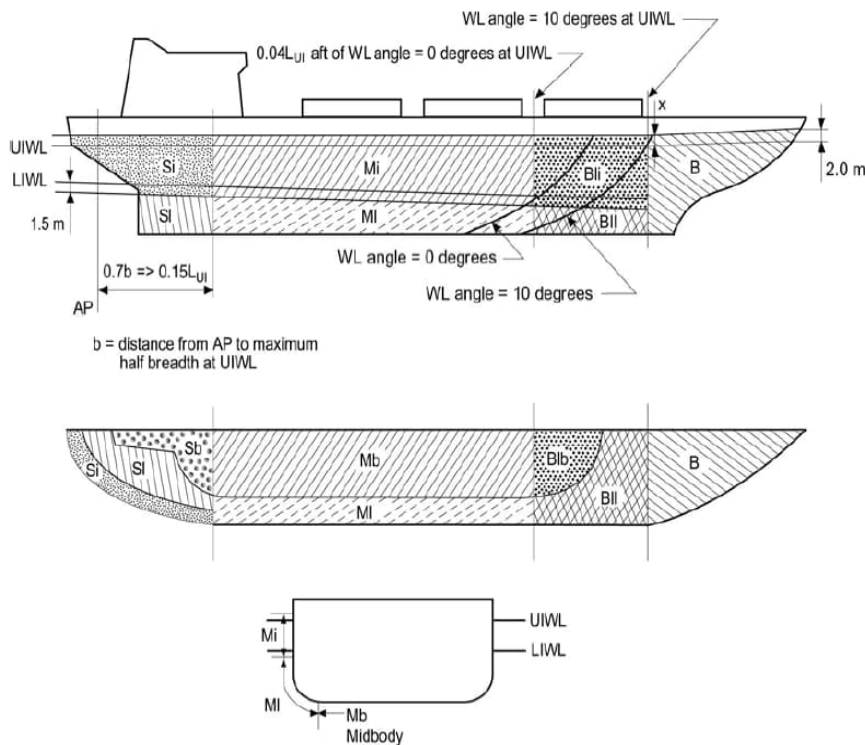
##### 1.2.5 (1/3/2008)

If a ship is intended to operate astern in ice regions, the aft section of the vessel is to be designed using the Bow and Bow Intermediate hull area requirements.

##### 1.2.6 (1/1/2021)

Fig 1 notwithstanding, if the ship is assigned the additional notation "Icebreaker", the forward boundary of the stern region is to be at least 0.04  $L_{UI}$  forward of the section where the parallel ship side at the upper ice waterline (UIWL).

Figure 1 : Extent of hull areas (1/1/2021)



### 1.3 Direct calculations

#### 1.3.1 (1/7/2017)

Direct calculations are not to be utilised as an alternative to the analytical methods prescribed for the shell plating and ordinary stiffeners requirements given in [6.2], [7.4] and [7.5].

#### 1.3.2 (1/7/2017)

Direct calculation are to be used for load carrying stringers and web frames forming part of a grillage system.

#### 1.3.3 (1/7/2017)

Where direct calculation is used to check the strength of structural systems, the load patch defined in [4] is to be applied without being combined with any other loads. The load patch is to be applied at locations where the capacity of these members under the combined effects of bending and shear is minimized. Special attention is to be paid to the shear capacity in way of lightening holes and cut-outs in way of intersecting members.

#### 1.3.4 (1/7/2017)

The strength evaluation of web frames and stringers may be performed based on linear or non-linear analysis. Recognized structural idealization and calculation method methods are to be applied. For linear analysis the requirements in Pt B, Ch 7, App 1 may be applied.

In the strength evaluation, the guidance given in [1.3.5] for linear calculations and [1.3.6] for non-linear calculations is generally to be considered.

#### 1.3.5 (1/7/2017)

If the structure is evaluated based on linear calculation methods other than those foreseen in Pt B, Ch 7, App 1, the following provisions are in any case to be considered:

- Web plates and flange elements in compression and shear are to fulfill the relevant buckling criteria as specified in Part B, Chapter 7;
- Nominal shear stresses in member web plates is to be less than  $\sigma_y$  (minimum upper yield stress of the material) divided by 3<sup>0.5</sup>;
- Nominal von Mises stresses in member flanges is to be less than  $\sigma_y$  (minimum upper yield stress of the material) multiplied by 1,15.

#### 1.3.6 (1/7/2017)

If the structure is evaluated based on non-linear calculation methods, the following provisions are in any case to be considered:

- the analysis is to reliably capture buckling and plastic deformation of the structure;
- the acceptance criteria are to ensure a suitable margin against fracture and major buckling and yielding causing significant loss of stiffness;
- permanent lateral and out-of plane deformation of the considered member are to be minor relative to the relevant structural dimensions.

Detailed acceptance criteria are to be proposed by the designer and will be evaluated by the Society on a case-by case basis.

## 2 Materials and welding

### 2.1 Material classes and grades

#### 2.1.1 (1/7/2017)

Steel grades of plating for hull structures are to be not less than those given in Tab 2 based on the as-built thickness, the **POLAR CLASS** and the material class of structural members given in Tab 1.

#### 2.1.2 (1/3/2008)

Material classes specified in Pt B, Ch 4, Sec 1, [2.4] are applicable to ships having an additional class notation **POLAR CLASS** regardless of the ship's length. In addition, material classes for weather and sea exposed structural members and for members attached to the weather and sea exposed plating are given in Tab 1. Where the material classes in Tab 1 differ from those in Pt B, Ch 4, Sec 1, Tab 3, the higher material class is to be applied.

#### 2.1.3 (1/3/2008)

Steel grades for all plating and attached framing of hull structures and appendages situated below the level of 0,3 m below the lower waterline, as shown in Fig 2, are to be obtained from Pt B, Ch 4, Sec 1, Tab 7 based on the material class for structural members in Tab 1 above, regardless of the **POLAR CLASS** assigned.

#### 2.1.4 (1/3/2008)

Steel grades for all weather exposed plating of hull structures and appendages situated above the level of 0,3 m below the lower ice waterline, as shown in Fig 2, are to be not less than given in Tab 2.

#### 2.1.5 (1/3/2008)

Castings are to have specified properties consistent with the expected service temperature for the cast component.

### 2.2 Welding

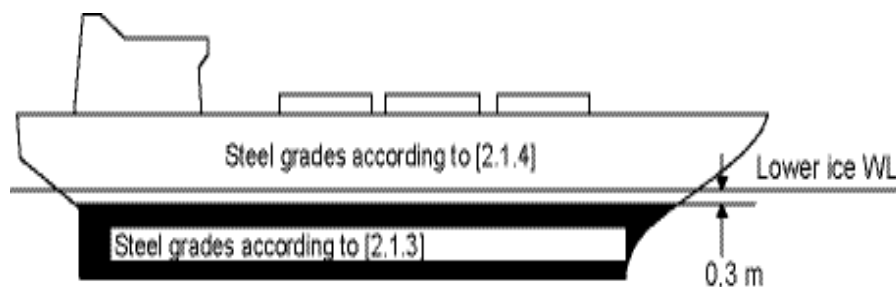
#### 2.2.1 (1/3/2008)

All weldings within ice-strengthened areas are to be of the double continuous type.

**Table 1 : Material classes for structural members of polar ships (1/1/2021)**

Structural members	Material class
Shell plating within the bow and bow intermediate icebelt hull areas (B, B <sub>ii</sub> )	II
All weather and sea exposed SECONDARY and PRIMARY structural members outside 0,4 L <sub>UJ</sub> amidships, as defined in Pt B, Ch 4, Sec 1, Tab 3	I
Plating materials for stem and stern frames, rudder horn, rudder, propeller nozzle, shaft brackets, ice skeg, ice knife and other appendages subject to ice impact loads	II
All inboard framing members attached to the weather and sea exposed plating, including any contiguous inboard member within 600 mm of the plating	I
Weather exposed plating and attached framing in cargo holds of ships which, by nature of their trade, have their cargo hold hatches open during cold weather operations	I
All weather and sea exposed SPECIAL structural members within 0,2 L <sub>UJ</sub> from FP, as defined in Pt B, Ch 4, Sec 1, Tab 3	II

**Figure 2 : Steel grade requirements for submerged and weather exposed shell plating (1/3/2008)**



**Table 2 : Steel grades for weather exposed plating (1) (3) (1/3/2008)**

As built thickness $t$ , in mm	Material class I				Material class II				Material class III					
	PC1-5		PC6 and 7		PC1-5		PC6 and 7		PC1-3		PC4 and 5		PC6 and 7	
	NSS	HSS	NSS	HSS	NSS	HSS	NSS	HSS	NSS	HSS	NSS	HSS	NSS	HSS
$t \leq 10$	B	AH	B	AH	B	AH	B	AH	E	EH	E	EH	B	AH
$10 < t \leq 15$	B	AH	B	AH	D	DH	B	AH	E	EH	E	EH	D	DH
$15 < t \leq 20$	D	DH	B	AH	D	DH	B	AH	E	EH	E	EH	D	DH
$20 < t \leq 25$	D	DH	B	AH	D	DH	B	AH	E	EH	E	EH	D	DH
$25 < t \leq 30$	D	DH	B	AH	E	EH (2)	D	DH	E	EH	E	EH	E	EH
$30 < t \leq 35$	D	DH	B	AH	E	EH	D	DH	E	EH	E	EH	E	EH
$35 < t \leq 40$	D	DH	D	DH	E	EH	D	DH	F	FH	E	EH	E	EH
$40 < t \leq 45$	E	EH	D	DH	E	EH	D	DH	F	FH	E	EH	E	EH
$45 < t \leq 50$	E	EH	D	DH	E	EH	D	DH	F	FH	F	FH	E	EH

(1) Includes weather exposed plating of hull structures and appendages, as well as their outboard framing members, situated above a level of 0,3 m below the lowest ice waterline.

(2) Grades D and DH are allowed for a single strake of side shell plating not more than 1,8 m wide from 0,3 m below the lowest ice waterline.

(3) "NSS" and "HSS" mean, respectively:  
"Normal Strength Steel" and "Higher Strength Steel".

### 3 Corrosion/abrasion additions and steel renewal

#### 3.1 Corrosion/abrasion addition

##### 3.1.1 (1/3/2008)

The value of corrosion/abrasion additions,  $t_c$ , to be applied to shell plating is to be taken equal to the greater of the following values:

- $t_c$  obtained from Pt B, Ch 4, Sec 2, [3.1]
- $t_c$  obtained from Tab 3, subject to the fitting of effective protection against corrosion and ice-induced abrasion.

##### 3.1.2 (1/3/2008)

The value of corrosion/abrasion additions,  $t_c$ , to be applied to all internal structures within the ice-strengthened hull areas, including plated members adjacent to the shell, as well as stiffeners, webs and flanges, is to be taken equal to the greater of the following values:

- $t_c$  obtained from Pt B, Ch 4, Sec 2, [3.1]
- $t_c = 1,0$  mm.

#### 3.2 Steel renewal

##### 3.2.1 (1/3/2008)

Steel renewal for ice-strengthened structures is required when the gauged thickness is less than  $t_{net} + 0,5$  mm.

### 4 Design ice loads

#### 4.1 General

##### 4.1.1 (1/7/2017)

A glancing impact on the bow is the design scenario for determining the scantlings required to resist ice loads.

##### 4.1.2 (1/3/2008)

The design ice load is characterised by an average pressure ( $P_{avg}$ ) uniformly distributed over a rectangular load patch of height ( $b$ ) and width ( $w$ ).

##### 4.1.3 (1/3/2008)

Within the bow area of all Polar Class ships, and within the bow intermediate icebelt area of Polar Class **PC6** and **PC7**, the ice load parameters are functions of the actual bow shape. To determine the ice load parameters ( $P_{avg}$ ,  $b$  and  $w$ ), it is necessary to calculate the following ice load characteristics for sub-regions of the bow area;

- shape coefficient ( $f_{ai}$ ),
- total glancing impact force ( $F_i$ ),
- line load ( $Q_i$ )
- pressure ( $P_i$ ).

##### 4.1.4 (1/3/2008)

In other ice strengthened areas, the ice load parameters ( $P_{avg}$ ,  $b_{NonBow}$  and  $w_{NonBow}$ ) are determined independently of the hull shape and based on a fixed load patch aspect ratio,  $AR = 3,6$ .

##### 4.1.5 (1/7/2017)

Design ice forces calculated according to [4.2] with the formulae from [4.3.3] to [4.3.8] are applicable for bow forms where the buttock angle  $\gamma$  at the stem is positive and less



than 80 deg, and the normal frame angle  $\beta'$  at the centre of the foremost sub-region, as defined in [4.3.1] and [4.3.2], is greater than 10 deg.

#### 4.1.6 (1/7/2017)

Design ice forces calculated according to [4.2] with the formulae from [4.3.9] to [4.3.13] are applicable for ships which are assigned the polar class **PC6** or **PC7** and have a bow form with vertical sides. This includes bows where the normal frame angles  $\beta'$  at the considered sub-regions, as defined in [4.3.1] and [4.3.2], are between 0 and 10 deg.

#### 4.1.7 (1/7/2017)

For ships which are assigned the polar class **PC6** or **PC7**, and equipped with bulbous bows, the design ice forces on the bow are to be determined according to [4.3.9] to

[4.3.13]. In addition, the design forces are not to be taken less than those given in [4.3.3] to [4.3.8], assuming  $f_a = 0.6$  and  $AR = 1.3$ .

#### 4.1.8 (1/7/2017)

For ships with bow forms other than those defined in [4.1.5] to [4.1.7], design ice forces are to be specially considered by the Society.

#### 4.1.9 (1/3/2008)

Ship structures that are not directly subjected to ice loads may still experience inertial loads of stowed cargo and equipment resulting from ship/ice interaction. These inertial loads, based on accelerations determined by the Society, are to be considered in the design of these structures.

**Table 3 : Corrosion/abrasion additions for shell plating (1/3/2008)**

Hull area	$t_c$ [mm]					
	With effective protection			Without effective protection		
	PC1 to PC3	PC4 and PC5	PC6 and PC7	PC1 to PC3	PC4 and PC5	PC6 and PC7
Bow; Bow Intermediate Icebelt	3,5	2,5	2,0	7,0	5,0	4,0
Bow Intermediate Lower; Midbody and Stern Icebelt	2,5	2,0	2,0	5,0	4,0	3,0
Midbody and Stern Lower; Bottom	2,0	2,0	2,0	4,0	3,0	2,5
Other Areas	2,0	2,0	2,0	3,5	2,5	2,0

## 4.2 Glancing impact load characteristics

#### 4.2.1 (1/7/2017)

The parameters defining the glancing impact load characteristics are reflected in the class factors listed in Tab 4 and Tab 5.

**Table 4 : Class Factors to be used in [4.3.3] to [4.3.8] (1/7/2017)**

Polar Class	Crushing Failure Class Factor ( $C_{FC}$ )	Flexural Failure Class Factor ( $C_{FF}$ )	Load Patch Dimensions Class Factor ( $C_{FD}$ )	Displacement Class Factor ( $C_{FDis}$ )	Longitudinal Strength Class Factor ( $C_{FL}$ )
<b>PC1</b>	17,69	68,60	2,01	250000	7,46
<b>PC2</b>	9,89	46,80	1,75	210000	5,46
<b>PC3</b>	6,06	21,17	1,53	180000	4,17
<b>PC4</b>	4,50	13,48	1,42	130000	3,15
<b>PC5</b>	3,10	9,00	1,31	70000	2,50
<b>PC6</b>	2,40	5,49	1,17	40000	2,37
<b>PC7</b>	1,80	4,06	1,11	22000	1,81

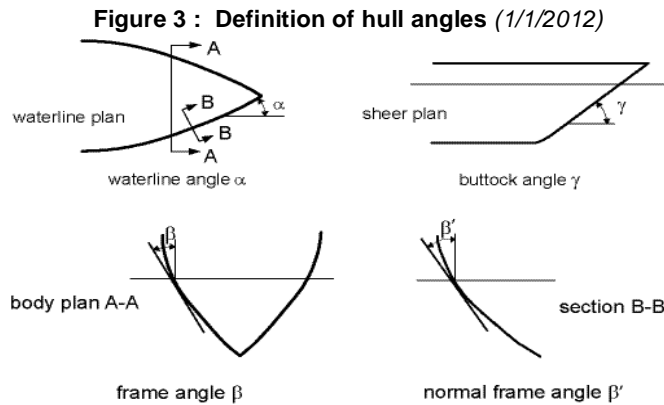
**Table 5 : Class Factors to be used in [4.3.9] to [4.3.13] (1/7/2017)**

Polar Class	Crushing Failure Class Factor ( $C_{FCV}$ )	Line load Class Factor ( $C_{FDQ}$ )	Pressure Class Factor ( $C_{FPV}$ )
PC6	3,43	2,82	0,65
PC7	2,60	2,33	0,65

### 4.3 Bow area

#### 4.3.1 General (1/3/2008)

In the bow area, the force (F), line load (Q), pressure (P) and load patch aspect ratio (AR) associated with the glancing impact load scenario are functions of the hull angles measured at the upper ice waterline (UIWL). The influence of the hull angles is captured through calculation of a bow shape coefficient (fa). The hull angles are defined in Fig 3.



- $\beta'$  : normal frame angle at upper ice waterline [deg]
- $\alpha$  : upper ice waterline angle [deg]
- $\gamma$  : buttock angle at upper ice waterline (angle of buttock line measured from horizontal) [deg]
- $\tan(\beta)$  :  $\tan(\alpha) / \tan(\gamma)$
- $\tan(\beta')$  :  $\tan(\beta) / \cos(\alpha)$

#### 4.3.3 Shape coefficient (1/1/2021)

For each sub-region, the shape coefficient,  $fa_i$ , for bow forms defined in [4.1.5], is to be obtained from the following formula:

$$fa_i = \min (fa_{i,1} ; fa_{i,2} ; fa_{i,3})$$

where:

- $fa_{i,1}$  :  $[(0,097 - 0,68 (x/L_{UI} - 0,15))^2] \alpha_i / (\beta'_i)^{0,5}$
- $fa_{i,2}$  :  $99,81 C_{FF} / [\sin(\beta'_i) C_{FC} \Delta_{UI}^{0,64}]$
- $fa_{i,3}$  : 0,60

#### 4.3.4 Force (1/1/2021)

For each sub-region and for bow forms defined in [4.1.5], the force F, in kN, is to be obtained from the following formula:

$$F_i = 12,02 fa_i C_{FC} \Delta_{UI}^{0,64}$$

#### 4.3.2 Sub-regions (1/7/2017)

The waterline length of the bow region is generally to be divided into 4 sub-regions of equal length. The force (F), line load (Q), pressure (P) and load patch aspect ratio (AR) are to be calculated with respect to the mid-length position of each sub-region (each maximum of F, Q and P is to be used in the calculation of the ice load parameters  $P_{avg}$ , b and w).

The bow area load characteristics for bow forms defined in [4.1.5] are determined as indicated in [4.3.3] to [4.3.8].

The bow area load characteristics for bow forms defined in [4.1.6] are determined as indicated in [4.3.9] to [4.3.13].

#### 4.3.5 Load patch aspect ratio (1/7/2017)

For each sub-region and for bow forms defined in [4.1.5], the load patch aspect ratio  $AR_i$  is to be obtained from the following formula:

$$AR_i = 7,46 \sin(\beta'_i) \text{ to be taken not less than } 1,3$$

#### 4.3.6 Line load (1/7/2017)

For each sub-region and for bow forms defined in [4.1.5], the line load Q, in kN/m, is to be obtained from the following formula:

$$Q_i = 14,79 F_i^{0,61} C_{FD} / AR_i^{0,35}$$

#### 4.3.7 Pressure (1/7/2017)

For each sub-region and for bow forms defined in [4.1.5], the pressure P, in kN/m<sup>2</sup>, is to be obtained from the following formula:

$$P_i = 218,78 F_i^{0,22} C_{FD}^2 AR_i^{0,3}$$

#### 4.3.8 Definitions (1/1/2021)

In the formulae from [4.3.3] to [4.3.7] the following definitions apply:

- i : sub-region considered
- $L_{UI}$  : length as defined in [1.1.1], in m

- $x$  : distance from the fore side of the stem at the intersection with the upper ice waterline (UIWL) to the station under consideration, in m
- $\alpha$  : waterline angle, in deg; see Fig 3
- $\beta'$  : normal frame angle in deg; see Fig 3
- $\Delta_{UI}$  : displacement as defined in [1.1.2], in t, to be taken not less than 5000 t
- $C_{FC}$  : crushing Failure Class Factor from Tab 4
- $C_{FF}$  : flexural Failure Class Factor from Tab 4
- $C_{FD}$  : Load Patch Dimensions Class Factor from Tab 4

#### 4.3.9 Shape coefficient (1/7/2017)

For each sub-region the shape coefficient,  $fa_i$ , for bow forms defined in [4.1.6], is to be taken as:

$$fa_i = \alpha_i / 30$$

#### 4.3.10 Force (1/1/2021)

For each sub-region and for bow forms defined in [4.1.6], the force  $F_i$ , in kN, is to be obtained from the following formula:

$$F_i = 38.9 \cdot fa_i \cdot C_{FCV} \cdot \Delta_{UI}^{0.47}$$

#### 4.3.11 Line load (1/1/2021)

For each sub-region and for bow forms defined in [4.1.6], the line load  $Q_i$ , in kN/m, is to be obtained from the following formula:

$$Q_i = 218.78 \cdot F_i^{0.22} \cdot C_{FQV}$$

#### 4.3.12 Pressure (1/1/2021)

For each sub-region and for bow forms defined in [4.1.6], the pressure  $P_i$ , in kN/m<sup>2</sup>, is to be obtained from the following formula:

$$P_i = 20.89 \cdot F_i^{0.56} \cdot C_{FPV}$$

#### 4.3.13 Definitions (1/1/2021)

In the formulae from [4.3.9] to [4.3.12] the following definitions apply:

- $i$  : sub-region considered
- $\alpha$  : waterline angle, in deg; see Fig 3
- $\Delta_{UI}$  : displacement as defined in [1.1.2], in t, to be taken not less than 5000 t
- $C_{FCV}$  : crushing Failure Class Factor from Tab 5
- $C_{FQV}$  : flexural Failure Class Factor from Tab 5
- $C_{FPV}$  : Pressure Class Factor from Tab 5

### 4.4 Hull areas other than the bow

#### 4.4.1 General (1/3/2008)

In hull areas other than the bow, the force ( $F_{NonBow}$ ) and line load ( $Q_{NonBow}$ ) used in the determination of the load patch dimensions ( $b_{NonBow}$ ,  $w_{NonBow}$ ) and design pressure ( $P_{avg}$ ) are determined as follows.

#### 4.4.2 Force (1/1/2021)

The force  $F_{NonBow}$ , in kN, is to be obtained from the following formula:

- if  $\Delta_{UI} \leq CF_{DIS}$ 

$$F_{NonBow} = 4.33 \cdot CF_C \cdot \Delta_{UI}^{0.64}$$

- if  $\Delta_{UI} > CF_{DIS}$

$$F_{NonBow} = 0.36 \cdot CF_C \cdot [12.02 \cdot CF_{DIS}^{0.64} + 0.10 (\Delta_{UI} - CF_{DIS})]$$

where:

- $CF_C$  : Crushing Force Class Factor from Tab 4
- $\Delta_{UI}$  : displacement as defined in [1.1.2], in t, to be taken not less than 10000 t
- $CF_{DIS}$  : Displacement Class Factor from Tab 4.

#### 4.4.3 Line Load (1/3/2008)

The line load  $Q_{NonBow}$ , in kN/m, is to be obtained from the following formula:

$$Q_{NonBow} = 9.452 \cdot F_{NonBow}^{0.61} \cdot CF_D$$

where:

- $CF_D$  : Load Patch Dimensions Class Factor from Tab 4.

### 4.5 Design load patch

#### 4.5.1 (1/7/2017)

In the Bow area, and the Bow Intermediate Icebelt area for ships with class notation **PC6** and **PC7**, the dimensions (width,  $w_{Bow}$ , and height,  $b_{Bow}$ ) in m, of the design load patch are to be obtained from the following formulae:

$$w_{Bow} = F_{Bow} / Q_{Bow}$$

$$b_{Bow} = Q_{Bow} / P_{Bow}$$

where:

- $F_{Bow}$  : maximum force  $F_i$  in the Bow area from the formula in [4.3.4] or [4.3.10], in kN
- $Q_{Bow}$  : maximum line load  $Q_i$  in the Bow area from the formula in [4.3.6] or [4.3.11], in kN/m
- $P_{Bow}$  : maximum pressure  $P_i$  in the Bow area from the formula in [4.3.7] or [4.3.12], in kN/m<sup>2</sup>.

#### 4.5.2 (1/7/2017)

In hull areas other than those covered by [4.5.1], the dimensions (width,  $w_{Bow}$ , and height,  $b_{Bow}$ ) in m, of the design load patch are to be obtained from the following formulae:

$$w_{NonBow} = F_{NonBow} / Q_{NonBow}$$

$$b_{NonBow} = w_{NonBow} / 3.6$$

where  $F_{NonBow}$  and  $Q_{NonBow}$  are defined in [4.4.2] and [4.4.3].

### 4.6 Pressure within the design load patch

#### 4.6.1 (1/3/2008)

The average pressure  $P_{avg}$ , in kN/m<sup>2</sup>, within the design load patch is to be obtained from the following formula:

$$P_{avg} = F / (b \cdot w)$$

where:

- $F$  :  $F_{Bow}$  or  $F_{NonBow}$ , in kN, as appropriate for the hull area under consideration
- $b$  :  $b_{Bow}$  or  $b_{NonBow}$  as appropriate for the hull area under consideration
- $w$  :  $w_{Bow}$  or  $w_{NonBow}$  as appropriate for the hull area under consideration.

Areas of higher concentrated pressure exist within the load patch. In general, smaller areas have higher local

pressures. Accordingly, the peak pressure factors listed in Tab 6 are used to account for the pressure concentration on localised structural members.

**Table 6 : Peak Pressure Factors (1/7/2017)**

Structural member		Peak pressure factor (PPF <sub>i</sub> )
Plating	Transversely framed	$PPF_p = (1,8 - s) \geq 1,2$
	Longitudinally framed	$PPF_p = (2,2 - 1,2 s) \geq 1,5$
Frames in transverse framing systems	With load distributing stringers	$PPF_t = (1,6 - s) \geq 1,0$
	With no load distributing stringers	$PPF_t = (1,8 - s) \geq 1,2$
Frames in bottom structures		$PPF_s = 1$
Load-carrying stringers, side longitudinals, web frames		if $S_w \geq 0,5 w$ $PPF_s = 1$ if $S_w < (0,5 w)$ $PPF_s = 2,0 - 2,0 S_w w$
where: s = frame or longitudinal spacing, in m. $S_w$ = web frame spacing, in m w = ice load patch width, in m		

**4.7 Hull area factors**

**4.7.1 (1/7/2017)**

Associated with each hull area is an area factor that reflects the relative magnitude of the load expected in that area. The area factor AF for each hull area is listed in Tab 7.

In the event that a structural member spans across the boundary of a hull area, the largest hull area factor is to be used in the scantling determination of the member.

Due to their increased manoeuvrability, ships having propulsion arrangements with azimuthing thruster(s) or "podded" propellers are to have specially considered Stern Icebelt (S<sub>i</sub>) and Stern Lower (S<sub>l</sub>) hull area factors.

For ships assigned the additional notation "Icebreaker", the Area Factor (AF) for each hull area is listed in Tab 8.

**Table 7 : Hull area factors (AF) (1/3/2008)**

Hull area		Area	Polar Class						
			PC1	PC2	PC3	PC4	PC5	PC6	PC7
Bow (B)	All	B	1,00	1,00	1,00	1,00	1,00	1,00	1,00
Bow Intermediate (BI)	Icebelt/Lower	BI <sub>i</sub>	0,90	0,85	0,85	0,80	0,80	1,00 (1)	1,00 (1)
	Bottom	BI <sub>b</sub>	0,70	0,65	0,65	0,60	0,55	0,55	0,50
	Bottom	BI <sub>b</sub>	0,55	0,50	0,45	0,40	0,35	0,30	0,25
Midbody (M)	Icebelt	M <sub>i</sub>	0,70	0,65	0,55	0,55	0,50	0,45	0,45
	Lower	M <sub>l</sub>	0,50	0,45	0,40	0,35	0,30	0,25	0,25
	Bottom	M <sub>b</sub>	0,30	0,30	0,25	(2)	(2)	(2)	(2)
Stern (S)	Icebelt	S <sub>i</sub>	0,75	0,70	0,65	0,60	0,50	0,40	0,35
	Lower	S <sub>l</sub>	0,45	0,40	0,35	0,30	0,25	0,25	0,25
	Bottom	S <sub>b</sub>	0,35	0,30	0,30	0,25	0,15	(2)	(2)
(1) See [4.1.3]									
(2) Indicates that strengthening for ice loads is not necessary.									

**Table 8 : Hull area factors (AF) for ships with additional notation "Icebreaker" (1/7/2017)**

Hull area		Area	Polar Class						
			PC1	PC2	PC3	PC4	PC5	PC6	PC7
Bow (B)	All	B	1,00	1,00	1,00	1,00	1,00	1,00	1,00
Bow Intermediate (BI)	Icebelt Lower Bottom	BI <sub>i</sub>	0,90	0,85	0,85	0,85	0,85	1,00	1,00
	Lower	BI <sub>l</sub>	0,70	0,65	0,65	0,65	0,65	0,65	0,65
	Bottom	BI <sub>b</sub>	0,55	0,50	0,45	0,45	0,45	0,45	0,45
Midbody (M)	Icebelt	M <sub>i</sub>	0,70	0,65	0,55	0,55	0,55	0,55	0,55
	Lower	M <sub>l</sub>	0,50	0,45	0,40	0,40	0,40	0,40	0,40
	Bottom	M <sub>b</sub>	0,30	0,30	0,25	0,25	0,25	0,25	0,25
Stern (S)	Icebelt	S <sub>i</sub>	0,95	0,90	0,80	0,80	0,80	0,80	0,80
	Lower	S <sub>l</sub>	0,55	0,50	0,45	0,45	0,45	0,45	0,45
	Bottom	S <sub>b</sub>	0,35	0,30	0,30	0,30	0,30	0,30	0,30

## 5 Longitudinal strength

### 5.1 Application

#### 5.1.1 (1/7/2017)

A ramming impact on the bow is the design scenario for the evaluation of the longitudinal strength of the hull.

Intentional ramming is not considered as a design scenario for ships which are designed with vertical or bulbous bows, see Sec 1, [1.1.6]. Hence the longitudinal strength requirements given in [5] is not to be considered for ships with stem angle  $\gamma_{\text{stem}}$  equal to or larger than 80 deg.

Ice loads are only to be combined with still water loads. The combined stresses are to be compared against permissible bending and shear stresses at different locations along the ship's length. In addition, sufficient local buckling strength is also to be verified.

### 5.2 Hull girder ice loads

#### 5.2.1 Design vertical ice force at the bow (1/1/2021)

The design vertical ice force at the bow,  $F_{IB}$ , in kN, is to be taken as:

$$F_{IB} = \min(F_{IB,1}; F_{IB,2})$$

where:

$$F_{IB,1} = 1,505 K_I^{0,15} \sin^{0,2}(\gamma_{\text{stem}}) (\Delta_{UI} K_h)^{0,5} CF_L$$

$$F_{IB,2} = 1200 CF_F$$

$K_I$  = indentation parameter =  $K_f / K_h$ , where  $K_f$  and  $K_h$ , in kN/m, are to be taken according to the following formulae:

$$K_f = [2 C B_{UI}^{1-e_b} / (1 + e_b)]^{0,9} \tan(\gamma_{\text{stem}})^{-0,9(1+e_b)}$$

$$K_h = 10 A_{wp}$$

$CF_L$  = Longitudinal Strength Class Factor from Tab 4

$e_b$  = bow shape exponent which best describes the waterplane (see Fig 5), to be taken as follows:

- $e_b = 1,0$  for a simple wedge bow form
- $e_b = 0,4$  to  $0,6$  for a spoon bow form
- $e_b = 0$  for a landing craft bow form

An approximate value of  $e_b$  determined by a simple fit is acceptable.

$\gamma_{\text{stem}}$  : stem angle, in deg, to be measured between the horizontal axis and the stem tangent at the upper ice waterline (buttock angle as per Fig 3 measured on the centreline)

$\alpha_{\text{stem}}$  : waterline angle measured in way of the stem at the upper ice waterline (UIWL) (deg) (see Fig 5)

$$C = 1 / [2 (L_B / B_{UI})^{e_b}]$$

$B_{UI}$  : moulded breadth, in m, corresponding to the upper ice waterline (UIWL)

$L_B$  : bow length, in m

$y$  :  $B_{UI} / 2 (x/L_B)^{e_b}$ , in m (see Fig 5 and Fig 7)

$\Delta_{UI}$  : displacement as defined in [1.1.2], in t, to be taken not less than 10000 t

$A_{wp}$  : waterplane area, in m<sup>2</sup>, corresponding to the upper ice waterline (UIWL)

$CF_F$  : Flexural Failure Class Factor from Tab 4.

Figure 4 : Bow Shape Definition (1/1/2021)

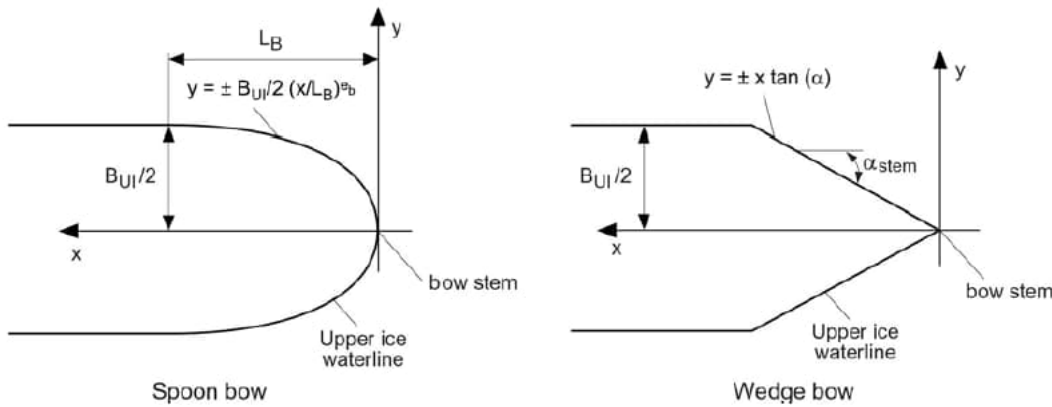
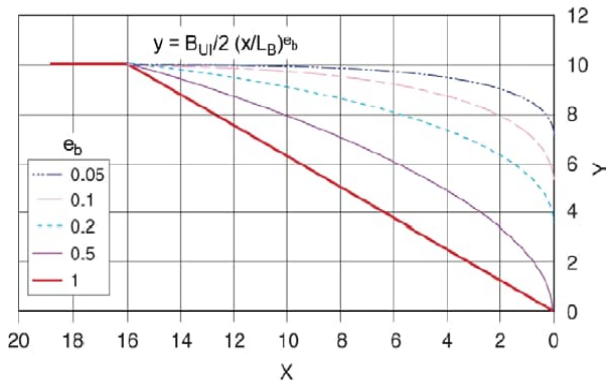


Figure 5 : Example of  $e_b$  effect on the bow shape for  $B_{UJ} = 20$  and  $L_B = 16$  (1/1/2021)



**5.2.2 Design vertical ice bending moment (1/1/2021)**

The design vertical ice bending moment  $M_I$ , in kN-m, along the hull girder is to be taken as:

$$M_I = 0,1 C_m L_{UJ} \sin^{0,2}(\gamma_{stem}) F_{IB}$$

where:

- $L_{UJ}$  : length as defined in [1.1.1], in m
- $\gamma_{stem}$  : as given in [5.2.1]
- $F_{IB}$  : design vertical ice force at the bow, in kN
- $C_m$  : longitudinal distribution factor for the design vertical ice bending moment to be taken as follows:
  - $C_m = 0,0$  at the aft end of  $L_{UJ}$
  - $C_m = 1,0$  between  $0,5 L_{UJ}$  and  $0,7 L_{UJ}$  from aft
  - $C_m = 0,3$  at  $0,95 L_{UJ}$  from aft
  - $C_m = 0,0$  at the forward end of  $L_{UJ}$

Intermediate values are to be determined by linear interpolation.

**5.2.3 Applied vertical bending stress (1/1/2021)**

The applied vertical bending stress,  $\sigma_a$ , is to be determined along the hull girder in a similar manner as in Pt B, Ch 6, Sec 2, [2], by substituting the design vertical ice bending moment for the design vertical wave bending moment. The

ship still water bending moment is to be taken as the permissible still water bending moment in sagging condition.

**5.2.4 Design vertical ice shear force (1/1/2021)**

The design vertical ice shear force  $F_I$ , in kN, along the hull girder is to be taken as:

$$F_I = C_f F_{IB}$$

where:

$C_f$  : longitudinal distribution factor to be taken as follows:

- For positive shear force:
  - $C_f$  : 0,0 between the aft end of  $L_{UJ}$  and  $0,6 L_{UJ}$  from aft
  - $C_f$  : 1,0 between  $0,9 L_{UJ}$  from aft and the forward end of  $L_{UJ}$
- For negative shear force
  - $C_f$  : 0,0 at the aft end of  $L_{UJ}$
  - $C_f$  : -0,5 between  $0,2 L_{UJ}$  and  $0,6 L_{UJ}$  from aft
  - $C_f$  : 0,0 between  $0,8 L_{UJ}$  from aft and the forward end of  $L_{UJ}$

Intermediate values are to be determined by linear interpolation.

**5.3 Longitudinal strength criteria**

**5.3.1 (1/3/2008)**

The strength criteria provided in Tab 9 are to be satisfied. The design stress is not to exceed the permissible stress.

**6 Shell plating**

**6.1 Definitions**

**6.1.1 (1/7/2017)**

- $\Omega$  : smallest angle, in deg, between the chord of the waterline and the line of the first level framing as illustrated in Fig 6
- s : transverse frame spacing, in m, in transversely framed ships or longitudinal frame spacing in longitudinally framed ships
- AF : Hull Area Factor from Tab 7 or Tab 8

- PPF<sub>p</sub> : Peak Pressure Factor from Tab 6
- P<sub>avg</sub> : average patch pressure, in kN/m<sup>2</sup>, according to [4.6]
- σ<sub>y</sub> : minimum upper yield stress of the material, in N/mm<sup>2</sup>
- b : height of design load patch, in m
- l : distance, in m, between frame supports, i.e. equal to the frame span as given in [7.1.4], but not reduced for any fitted end brackets. When a load-distributing stringer is fitted, the length l need not be taken larger than the distance from the stringer to the most distant frame support.

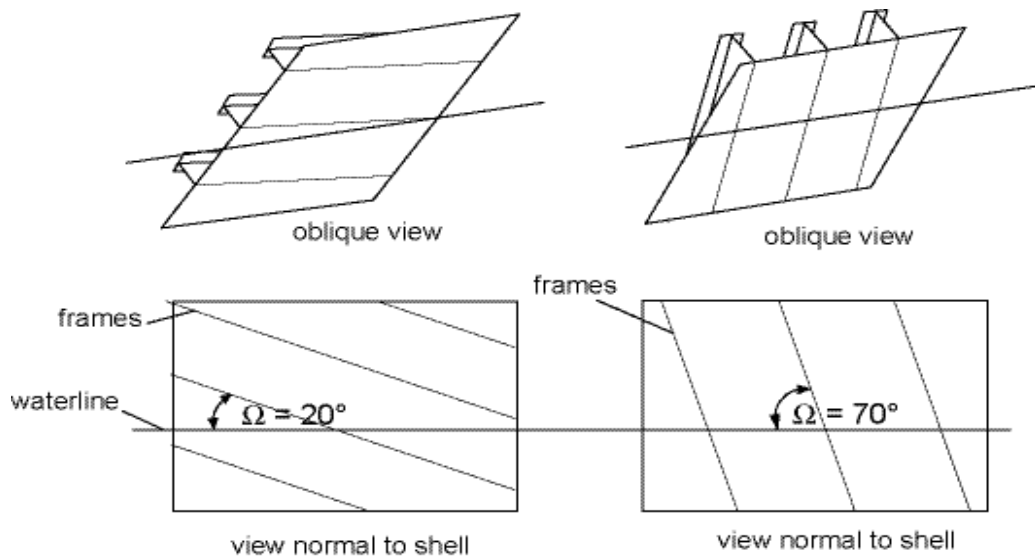
**Table 9 : Longitudinal strength criteria (1/7/2017)**

Failure Mode	Applied Stress	Permissible Stress when: σ <sub>y</sub> / σ <sub>u</sub> ≤ 0,7	Permissible Stress when: σ <sub>y</sub> / σ <sub>u</sub> > 0,7
Tension	σ <sub>a</sub>	η σ <sub>y</sub>	η 0,41 (σ <sub>u</sub> + σ <sub>y</sub> )
Shear	τ <sub>a</sub>	η σ <sub>y</sub> / (3) <sup>0.5</sup>	η 0,41 (σ <sub>u</sub> + σ <sub>y</sub> ) / (3) <sup>0.5</sup>
Buckling	σ <sub>a</sub>	σ <sub>c</sub> for plating and for web plating of stiffeners σ <sub>c</sub> / 1,1 for stiffeners	
	τ <sub>a</sub>	τ <sub>c</sub>	

**Note 1:** Meaning of symbols:

- σ<sub>a</sub> : applied vertical bending stress, in N/mm<sup>2</sup>
- τ<sub>a</sub> : applied vertical shear stress, in N/mm<sup>2</sup>
- σ<sub>y</sub> : minimum upper yield stress of the material, in N/mm<sup>2</sup>
- σ<sub>u</sub> : ultimate tensile strength of the material, in N/mm<sup>2</sup>
- σ<sub>c</sub> : critical buckling stress in compression, according to Pt B, Ch 7, Sec 1, [5.3.1] in N/mm<sup>2</sup>
- τ<sub>c</sub> : critical buckling stress in compression, according to Pt B, Ch 7, Sec 1, [5.3.1] in N/mm<sup>2</sup>
- η : 0,8 in all cases except otherwise stated.  
0,6 for ships which are assigned the additional notation "Icebreaker".

**Figure 6 : Shell Framing Angle Ω (1/3/2008)**



**6.2 Required thickness**

**6.2.1 (1/3/2008)**

The required minimum shell plating thickness t, in mm, is not to be less than the value obtained from the following formula:

$$t = t_{net} + t_c$$

where:

t<sub>net</sub> : plate thickness required to resist ice loads according to [6.3], in mm

t<sub>c</sub> : corrosion and abrasion allowance according to [3.1], in mm.

**6.2.2 (1/3/2008)**

The thickness of shell plating required to resist the design ice load, t<sub>net</sub>, depends on the orientation of the framing.





- $h$ ,  $t_{wn}$ ,  $t_c$ , and  $\phi_w$  are as given in [7.2] and  $s$  as given in [6.1]
- $A_{pn}$  : net cross-sectional area, in  $\text{cm}^2$ , of the local frame
- $t_{pn}$  : fitted net shell plate thickness, in mm (to complying with  $t_{net}$  as required by [6.1])
- $h_w$  : height, in mm, of local frame web; see Fig 7
- $A_{fn}$  : net cross-sectional area, in  $\text{cm}^2$ , of local frame flange
- $h_{fc}$  : height, in mm, of local frame measured at mid-thickness of the flange; see Fig 7
- $b_w$  : distance from mid-thickness plane of local frame web to the centre of the flange area; see Fig 7.

When the cross-sectional area of the local frame exceeds the cross-sectional area of the attached plate flange, the plastic neutral axis is located at a distance  $Z_{na}$ , in mm, above the attached shell plate, given by:

$$Z_{na} = (100A_{fn} + h_w t_{wn} - 1000 t_{pn} s) / (2 t_{wn})$$

and the net effective plastic section modulus,  $Z_p$ , in  $\text{cm}^3$ , of a transverse or longitudinal frame is given by:

$$Z_p = t_{pn} s Z_{na} \sin \phi_w + \left\{ \frac{[(h_w - Z_{na})^2 + Z_{na}^2] t_{wn} \sin \phi_w}{2000} + A_{fn} [(h_{fc} \div Z_{na}) \sin \phi_w - b_w \cos \phi_w] / 10 \right\}$$

In the case of oblique framing arrangement ( $70^\circ > \Omega > 20^\circ$ , where  $\Omega$  is defined as given in [6.1]), linear interpolation is to be used.

## 7.4 Ordinary stiffeners in bottom and in transversely stiffened side structures

### 7.4.1 Definitions (1/7/2017)

The ordinary stiffeners in bottom structures (i.e. hull areas  $B_{lb}$ ,  $M_b$  and  $S_b$ ) and in transversely stiffened side structures are to be dimensioned such that the combined effects of shear and bending do not exceed the plastic strength of the member. The plastic strength is defined by the magnitude of midspan load that causes the development of a plastic collapse mechanism. For the bottom structure the patch load shall be applied with the dimension  $b$ , (see below) parallel with the ordinary stiffener direction.

- LL : length of loaded portion of span, in m, to be taken as the lesser of  $a$  and  $b$
- $a$  : frame span, in m, as defined in [7.1.4]
- $b$  : height, in m, of design ice load patch according to [4.5.1] or [4.5.2]
- $s$  : spacing of ordinary stiffener, in m
- AF : Hull Area Factor from Tab 7
- PPF<sub>t</sub> : Peak Pressure Factor from Tab 6
- $P_{avg}$  : average pressure, in  $\text{kN/m}^2$ , within load patch according to [4.6]
- $\sigma_y$  : minimum upper yield stress of the material, in  $\text{N/mm}^2$ .

### 7.4.2 (1/3/2008)

The actual net effective shear area of transverse ordinary stiffeners,  $A_w$ , in  $\text{cm}^2$ , as defined in [7.2], is to comply with the following condition:

$$A_w \geq A_t$$

where:

$$A_t = 8,67 \text{ LL } s (\text{AF PPF}_t P_{avg}) / \sigma_y.$$

### 7.4.3 (1/7/2017)

The actual net effective plastic section modulus of the plate/stiffener combination  $Z_p$ , in  $\text{cm}^3$ , as defined in [7.3], is to comply with the following condition:

$$Z_p \geq 250 \text{ LL } (1 - 0,5 \text{ LL } / a) s (\text{AF PPF}_t P_{avg}) a A_1 / \sigma_y$$

where  $A_1$  is the greater of the following values:

- $A_{1A} = 1 / \{1 + j / 2 + k_w j / 2 [(1 - a_1^2)^{0,5} - 1]\}$
- $A_{1B} = \{1 - 1 / [2a_1 (1 - 0,5 \text{ LL} / a)]\} / (0,275 + 1,44 k_z^{0,7})$

where:

$j = 1$  for an ordinary stiffener with one simple support outside the ice strengthened areas

$j = 2$  for an ordinary stiffener without any simple supports

$$a_1 = A_t / A_w$$

$A_t$  : minimum shear area of the ordinary stiffener as given in [7.4.2]

$A_w$  : effective net shear area of the ordinary stiffener (calculated according to [7.2])

$k_w$  :  $1 / (1 + 2 A_{fn} / A_w)$  with  $A_{fn}$  as given in [7.3]

$k_z$  :  $Z_p / Z_p$  in general, to be assumed = 0 when the frame is arranged with end bracket

$Z_p$  : sum of individual plastic section moduli of flange and shell plate as fitted, in  $\text{cm}^3$ , to be obtained from the following formula:

$$Z_p = (b_f t^2 + b_{eff} t_{pn}^2) / 4000$$

$t_{fn}$  : net flange thickness, in mm, given by:  $t_f - t_c$  ( $t_c$  as given in [7.2])

$t_f$  : as-built flange thickness, in mm; see Fig 7

$t_{pn}$  : fitted net shell plate thickness, in mm (not to be less than  $t_{net}$  as given in [6])

$b_{eff}$  : effective width, in mm, of shell plate flange, to be assumed as 500 s

$Z_p$  : net effective plastic section modulus, in  $\text{cm}^3$ , of the ordinary stiffener (calculated according to [7.3]).

### 7.4.4 (1/7/2017)

The scantlings of the ordinary stiffeners are to meet the structural stability requirements of [7.7].

## 7.5 Longitudinal ordinary stiffeners in side structures

### 7.5.1 Definitions (1/7/2017)

Longitudinal ordinary stiffeners in side structures are to be dimensioned such that the combined effects of shear and bending do not exceed the plastic strength of the member. The plastic strength is defined by the magnitude of midspan load that causes the development of a plastic collapse mechanism.

- AF : Hull Area Factor from Tab 7  
 PPF<sub>s</sub> : Peak Pressure Factor from Tab 6  
 P<sub>avg</sub> : average pressure, in kN/m<sup>2</sup>, within load patch according to [7.4.1]  
 b : height, in m, of design ice load patch according to [4.5.1] and [4.5.2]  
 s : spacing of longitudinal frames, in m  
 a : effective span of longitudinal ordinary stiffener as given in [7.1.4], in m  
 σ<sub>y</sub> : minimum upper yield stress of the material, in N/mm<sup>2</sup>  
 b<sub>1</sub> : k<sub>o</sub> b<sub>2</sub>  
 k<sub>o</sub> : 1 - 0,3 / b'  
 b' : b / s  
 b<sub>2</sub> : to be taken in accordance with the following formulae:  
 • if b' < 2  
     b<sub>2</sub> = b (1 - 0,25 b')  
 • if b' ≥ 2  
     b<sub>2</sub> = s.

#### 7.5.2 Actual net effective shear area (1/7/2017)

The actual net effective shear area A<sub>w</sub>, in cm<sup>2</sup>, of longitudinal ordinary stiffeners, as defined in [7.2], is to comply with the following condition:

$$A_w \geq A_t$$

where:

$$A_t = 8,67 (AF \text{ PPF}_s \text{ P}_{avg}) 0,5 b_1 a / \sigma_y.$$

#### 7.5.3 Actual net effective plastic section modulus (1/7/2017)

The actual net effective plastic section modulus, in cm<sup>3</sup>, of the plate/stiffener combination, Z<sub>p</sub>, as defined in [7.3], is to comply with the following condition:

$$Z_p \geq Z_{pl}$$

where:

$$Z_{pl} = 125 (AF \text{ PPF}_s \text{ P}_{avg}) b_1 a^2 A_4 / \sigma_y$$

$$A_4 : 1 / \{2 + k_{wl} [(1 - a_4^2)^{0,5} - 1]\}$$

$$a_4 : A_L / A_w$$

A<sub>L</sub> : minimum shear area for longitudinal as given in [7.5.2], in cm<sup>2</sup>

A<sub>w</sub> : net effective shear area of longitudinal (calculated according to [7.2.1]), in cm<sup>2</sup>

$$k_{wl} : 1 / (1 + 2 A_{fn} / A_w) \text{ with } A_{fn} \text{ as given in [7.3].}$$

AF : Hull Area Factor from Tab 7 or Tab 8

PPF<sub>s</sub> : Peak Pressure Factor from Tab 6

P<sub>avg</sub> : average pressure, in kN/m<sup>2</sup>, within load patch according to [7.4.1]

b : height, in m, of design ice load patch according to [4.5.1] and [4.5.2].

#### 7.5.4 Actual net effective plastic section modulus (1/3/2008)

The scantlings of longitudinal stiffeners are to meet the structural stability requirements of [7.7].

## 7.6 Web frames and load-carrying stringers

### 7.6.1 (1/3/2008)

Web frames and load-carrying stringers are to be designed to withstand the ice load patch as defined in [4]. The load patch is to be applied at locations where the capacity of these members under the combined effects of bending and shear is minimised.

### 7.6.2 (1/7/2017)

Web frames and load-carrying stringers are to be dimensioned such that the combined effects of shear and bending do not exceed the limit state(s) defined Pt B, Ch 7, Sec 3.

Where the structural configuration is such that members do not form part of a grillage system, the appropriate peak pressure factor (PPF) from Tab 6 is to be used. Special attention is to be paid to the shear capacity in way of lightening holes and cut-outs in way of intersecting members.

### 7.6.3 (1/7/2017)

For determination of scantlings of load carrying stringers, web frames supporting ordinary stiffeners, or web frames supporting load carrying stringers forming part of a structural grillage system, appropriate methods as outlined in [1.2] are normally to be used.

### 7.6.4 (1/3/2008)

The scantlings of web frames and load-carrying stringers are to meet the structural stability requirements of [7.7].

## 7.7 Framing - Structural stability

### 7.7.1 (1/3/2008)

To prevent local buckling in the web, the ratio of web height (h<sub>w</sub>) to net web thickness (t<sub>wn</sub>) of any framing member is not to exceed:

• For flat bar sections:

$$h_w / t_{wn} \leq 282 / (\sigma_y)^{0,5}$$

• For bulb, tee and angle sections:

$$h_w / t_{wn} \leq 805 / (\sigma_y)^{0,5}$$

where:

h<sub>w</sub> : web height, in mm

t<sub>wn</sub> : net web thickness, in mm

σ<sub>y</sub> : minimum upper yield stress of the material, in N/mm<sup>2</sup>.

### 7.7.2 (1/1/2012)

Framing members for which it is not practicable to meet the requirements of [7.7.1] (e.g. load-carrying stringers or deep web frames) are required to have their webs effectively stiffened. The scantlings of the web stiffeners are to ensure the structural stability of the framing member. The minimum net web thickness, in mm, for these framing members is given by the following formula:

$$t_{wn} = 2,63 \times 10^{-3} \times c_1 \sqrt{\sigma_y / [5,34 + 4(c_1/c_2)^2]}$$

where:

c<sub>1</sub> : h<sub>w</sub> - 0,8 h<sub>i</sub>, in mm

h<sub>w</sub> : web height, in mm, of stringer / web frame (see Fig 8)

- $h$  : height, in mm, of framing member penetrating the member under consideration (equal to 0 if no such framing member) (see Fig 8)
- $c_2$  : spacing, in mm, between supporting structure oriented perpendicular to the member under consideration (see Fig 8)
- $\sigma_y$  : minimum upper yield stress of the material, in N/mm<sup>2</sup>.

### 7.7.3 (1/1/2012)

In addition to [7.7.1] and [7.7.2], the following is to be satisfied:

$$t_{wn} \geq 0,35 t_{pn} (\sigma_y / 235)^{0,5}$$

where:

- $\sigma_y$  : minimum upper yield stress of the shell plate in way of the framing member, in N/mm<sup>2</sup>
- $t_{wn}$  : net thickness of the web, in mm
- $t_{pn}$  : net thickness of the shell plate in way of the framing member, in mm.

### 7.7.4 (1/3/2008)

To prevent local flange buckling of welded profiles, the following conditions are to be satisfied:

$$b'_f / t_{wn} \geq 5$$

$$b_{out} / t_{fn} = 155 / (\sigma_y)^{0,5}$$

where:

- $b_{out}$  : width of the flange outstand, in mm
- $t_{fn}$  : net thickness of flange, in mm
- $\sigma_y$  : minimum upper yield stress of the material, in N/mm<sup>2</sup>.

## 8 Plated structures

### 8.1

#### 8.1.1 (1/3/2008)

Plated structures are those stiffened plate elements in contact with the hull and subject to ice loads. These requirements are applicable to an inboard extent which is the lesser of:

- the web height of the adjacent parallel web frame or stringer; or
- 2,5 times the depth of framing that intersects the plated structure.

### 8.2

#### 8.2.1 (1/3/2008)

The thickness of the plating and the scantlings of attached stiffeners are to be such that the degree of end fixity necessary for the shell framing is ensured.

### 8.3

#### 8.3.1 (1/3/2008)

The stability of the plated structure is to adequately withstand the ice loads defined in [4].

## 9 Stem and stern arrangement

### 9.1 Fore part

#### 9.1.1 Stem (1/3/2008)

The stem may be made of rolled, cast or forged steel or of shaped steel plates.

A sharp edged stem (see Fig 9) improves the manoeuvrability of the ship in ice and is particularly recommended for smaller ships under 150 m in length.

Figure 8: Parameter definition for web stiffening (1/3/2008)

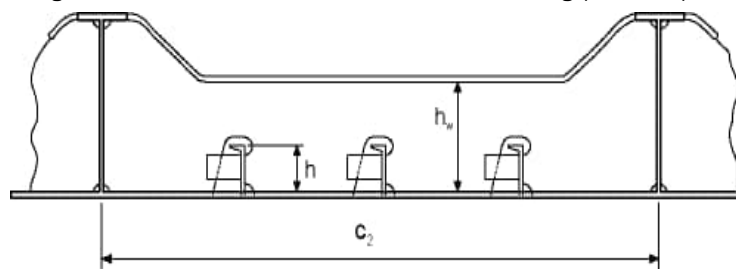
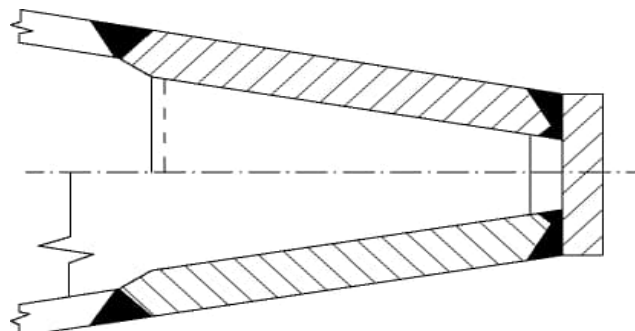


Figure 9 (1/3/2008)



The plate thickness of a shaped plate stem and, in the case of a blunt bow, any part of the shell which forms an angle of 30° or more to the centreline in a horizontal plane, is to be not less than 1,3 times the thickness of the adjacent shell plating calculated according to [6].

The stem and the part of a blunt bow defined above are to be supported by floors or brackets spaced not more than 600 mm apart and having a thickness at least half that of the plate.

The reinforcement of the stem is to be extended from the keel to the upper level of the bow region.

## 9.2 Aft part

### 9.2.1 (1/3/2008)

An extremely narrow clearance between the propeller blade tip and the sternframe is to be avoided so as not to generate very high loads on the blade tip.

### 9.2.2 (1/3/2008)

On twin and triple screw ships, the ice strengthening of the shell and framing is to be extended to the double bottom for at least 1,5 m forward and aft of the side propellers.

### 9.2.3 (1/3/2008)

Shafting and sterntubes of side propellers are generally to be enclosed within plated bossings. If detached struts are used, their design, strength and attachment to the hull are to be examined by the Society on a case-by-case basis.

### 9.2.4 (1/3/2008)

A wide transom stern extending below the UIWL seriously impedes the capability of the ship to run astern in ice, which is of paramount importance.

Consequently, a transom stern is not normally to be extended below the UIWL. Where this cannot be avoided, the part of the transom below the UIWL is to be kept as narrow as possible.

The part of a transom stern situated within the ice-strengthened area is to be strengthened as required for the midship region.

## 10 Hull outfitting

### 10.1 Appendages

#### 10.1.1 (1/3/2008)

All appendages are to be designed to withstand forces appropriate for the location of their attachment to the hull structure or their position within a hull area.

### 10.2 Rudders and steering arrangements

#### 10.2.1 (1/3/2008)

The scantlings of the rudder post, rudder stock, pintles, steering gear, etc as well as the capacity of the steering gear

are to be determined according to Pt B, Ch 10, Sec 1, taking the coefficient  $r_2$ , defined in Pt B, Ch 10, Sec 1, [2.1.2], equal to 1,10 irrespective of the rudder profile type.

However, the maximum ahead service speed of the ship to be used in these calculations is not to be taken less than that stated in Tab 10.

Where the actual maximum ahead service speed of the ship is greater than that stated in Tab 10, the higher speed is to be used.

Within the ice-strengthened zone, the thickness of rudder plating and diaphragms is to be not less than that required for the shell plating of the aft region.

#### 10.2.2 (1/3/2008)

The rudder stock and the upper edge of the rudder are to be protected against ice pressure by an ice knife or equivalent means.

## 10.3 Arrangements for towing

### 10.3.1 (1/3/2008)

A mooring pipe with an opening not less than 250 mm by 300 mm, a length of at least 150 mm and an inner surface radius of at least 100 mm is to be fitted in the bow bulwark on the centreline.

### 10.3.2 (1/3/2008)

A bitt or other means of securing a towline is to be fitted, dimensioned to withstand the breaking strength of the ship's towline.

### 10.3.3 (1/3/2008)

On ships with a displacement less than 30000 t, the part of the bow extending to a height of at least 5 m above the UIWL and at least 3 m back from the stem is to be strengthened to withstand the stresses caused by fork towing. For this purpose, intermediate ordinary stiffeners are to be fitted and the framing is to be supported by stringers or decks.

**Table 10 : Maximum ahead service speed (1/3/2008)**

Notation	Maximum ahead service speed (knots)
POLAR CLASS 1	26
POLAR CLASS 2	24
POLAR CLASS 3	23
POLAR CLASS 4	22
POLAR CLASS 5	21
POLAR CLASS 6	20
POLAR CLASS 7	18

## SECTION 3

## MACHINERY

### 1 General

#### 1.1 Application

##### 1.1.1 (1/3/2008)

This Section applies to main propulsion, steering gear, emergency and essential auxiliary systems required for the safety of the ship and the survivability of the crew.

#### 1.2 Drawings and particulars to be submitted

##### 1.2.1 (1/3/2008)

Details of the environmental conditions and the required polar class for the machinery, if different from the ship's polar class.

##### 1.2.2 (1/3/2008)

Detailed drawings of the main propulsion machinery. Description of the main propulsion, steering, and emergency and essential auxiliaries is to include operational limitations. Information on essential main propulsion load control functions.

##### 1.2.3 (1/3/2008)

Description detailing how main, emergency and auxiliary systems are located and protected to prevent problems from freezing, ice and snow, and evidence of their capability to operate in the intended environmental conditions.

##### 1.2.4 (1/3/2008)

Calculations and documentation indicating compliance with the requirements of this Section.

#### 1.3 System Design

##### 1.3.1 (1/3/2008)

Machinery and supporting auxiliary systems are to be designed, constructed and maintained to comply with the requirements of "periodically unmanned machinery spaces" with respect to fire safety. Any automation plant (i.e. control, alarm, safety and indication systems) for essential systems installed is to be maintained to the same standard.

##### 1.3.2 (1/3/2008)

Systems subject to damage by freezing are to be drainable.

##### 1.3.3 (1/3/2008)

Single screw ships classed PC1 to PC5 inclusive are to have means provided to ensure sufficient vessel operation in the case of propeller damage including CP-mechanism.

### 2 Materials

#### 2.1 Materials exposed to sea water

##### 2.1.1 (1/3/2008)

Materials exposed to sea water, such as propeller blades, propeller hub and blade bolts, are to have an elongation not

less than 15% on a test piece the length of which is five times the diameter.

Charpy V impact tests are to be carried out for other than bronze and austenitic steel materials. Test pieces taken from the propeller castings are to be representative of the thickest section of the blade. An average impact energy value of 20 J taken from three Charpy V tests is to be obtained at minus 10 °C.

#### 2.2 Materials exposed to sea water temperature

##### 2.2.1 (1/3/2008)

Materials exposed to sea water temperature are to be of steel or other approved ductile material.

An average impact energy value of 20 J taken from three tests is to be obtained at minus 10 °C.

#### 2.3 Material exposed to low air temperature

##### 2.3.1 (1/3/2008)

Materials of essential components exposed to low air temperature are to be of steel or other approved ductile material.

An average impact energy value of 20 J taken from three Charpy V tests is to be obtained at 10 °C below the lowest design temperature.

### 3 Ice interaction load

#### 3.1 Propeller ice interaction

##### 3.1.1 (1/3/2008)

This Section covers open and ducted type propellers situated at the stern of a ship having controllable pitch or fixed pitch blades. Ice loads on bow propellers and pulling type propellers are to receive special consideration. The given loads are expected, single occurrence, maximum values for the whole ship's service life for normal operational conditions. These loads do not cover off-design operational conditions, for example when a stopped propeller is dragged through ice. This Section also applies to azimuthing (geared and podded) thrusters, considering loads due to propeller ice interaction. However, ice loads due to ice impacts on the body of azimuthing thrusters are not covered by this Section.

The loads given in this item [3] are total loads (unless otherwise stated) during ice interaction, are to be applied separately (unless otherwise stated) and are intended for

component strength calculations only. The different loads given here are to be applied separately.

- $F_b$  is a force bending a propeller blade backwards when the propeller mills an ice block while rotating ahead.
- $F_f$  is a force bending a propeller blade forwards when the propeller interacts with an ice block while rotating ahead.

### 3.2 Ice Class factors

#### 3.2.1 (1/3/2008)

Tab 1 lists the design ice thickness and ice strength index to be used for estimation of the propeller ice loads.

Table 1 (1/3/2008)

Polar Class	$H_{ice}$ [m]	$S_{ice}$ [-]	$S_{gice}$ [-]
PC1	4,0	1,2	1,15
PC2	3,5	1,1	1,15
PC3	3,0	1,1	1,15
PC4	2,5	1,1	1,15
PC5	2,0	1,1	1,15
PC6	1,75	1	1
PC7	1,5	1	1

- $H_{ice}$  : Ice thickness for machinery strength design
- $S_{ice}$  : Ice strength index for blade ice force
- $S_{gice}$  : Ice strength index for blade ice torque.

from the blade trailing edge to a value of 0,2 chord length.

See load cases 1, 2 and 5 in Tab 3.

### 3.3 Design ice loads for open propeller

#### 3.3.1 Maximum backward blade force, $F_b$ (1/3/2008)

The maximum backward blade force  $F_b$ , in KN, is equal to:

- when  $D < D_{limit}$

$$F_b = -27S_{ice}(nD)^{0,7} \left(\frac{EAR}{Z}\right)^{0,3} (D)^2$$

- when  $D \geq D_{limit}$

$$F_b = -23S_{ice}(nD)^{0,7} \left(\frac{EAR}{Z}\right)^{0,3} (H_{ice})^{1,4} (D)$$

where:

- $D_{limit} = 0,85 (H_{ice})^{1,4}$ , in m
- $n$  is the nominal rotational speed (at MCR free running condition) for a CP propeller and 85% of the nominal rotational speed (at MCR free running condition) for a FP propeller (regardless of driving engine type)

$F_b$  is to be applied as a uniform pressure distribution to an area on the back (suction) side of the blade for the following load cases:

- Load case 1: from 0,6R to the tip and from the blade leading edge to a value of 0,2 chord length,
- Load case 2: a load equal to 50 % of the  $F_b$  is to be applied on the propeller tip area outside of 0,9R
- Load case 5: for reversible propellers a load equal to 60% of the  $F_b$ , is to be applied from 0,6R to the tip and

#### 3.3.2 Maximum forward blade force, $F_f$ (1/3/2008)

The maximum forward blade force,  $F_f$ , in KN, is equal to:

- when  $D < D_{limit}$

$$F_f = 250 \left(\frac{EAR}{Z}\right) (D)^2$$

- when  $D \geq D_{limit}$

$$F_f = 500 \left(\frac{1}{1 - \frac{d}{D}}\right) H_{ice} \left(\frac{EAR}{Z}\right) (D)$$

where:

$$D_{limit} = \left(\frac{2}{1 - \frac{d}{D}}\right) H_{ice}$$

- $d$  = propeller hub diameter, in m
- $D$  = propeller diameter, in m
- $EAR$  = expanded blade area ratio
- $Z$  = number of propeller blades.

$F_f$  is to be applied as a uniform pressure distribution to an area on the face (pressure) side of the blade for the following load cases:

- Load case 3: from 0,6R to the tip and from the blade leading edge to a value of 0,2 chord length
- Load case 4: a load equal to 50 % of the  $F_f$  is to be applied on the propeller tip area outside of 0,9R
- Load case 5: for reversible propellers a load equal to 60%  $F_f$  is to be applied from 0,6R to the tip and from the blade trailing edge to a value of 0,2 chord length,

See load cases 3, 4, and 5 in Tab 4.

### 3.3.3 Maximum blade spindle torque, $Q_{smax}$ (1/3/2008)

Spindle torque  $Q_{smax}$  around the spindle axis of the blade fitting is to be calculated for the load cases described both in [3.3.1] for  $F_b$  and in [3.3.2] for  $F_f$ . If these spindle torque values are less than the default value, in kNm, given below, the default minimum value is to be used.

Default value  $Q_{smax} = 0,25 F_{C_{0,7}}$

where:

$c_{0,7}$  = length, in m, of the blade chord at 0,7R radius

$F$  is either  $F_b$  or  $F_f$ , whichever has the greater absolute value.

### 3.3.4 Maximum propeller ice torque applied to the propeller (1/3/2008)

The maximum propeller ice torque  $Q_{max}$ , in kNm, is equal to:

- when  $D < D_{limit}$

$$Q_{max} = 105(1 - d/D)S_{qice}(P_{0,7}/D)^{0,16}(t_{0,7}/D)^{0,6}(nD)^{0,17}D^3$$

- when  $D \geq D_{limit}$

$$Q_{max} = 202(1 - d/D)S_{qice}H_{ice}^{1,1}(P_{0,7}/D)^{0,16}(t_{0,7}/D)^{0,6}(nD)^{0,17}D^{1,9}$$

where:

$D_{limit} = 1,81 H_{ice}$ , in m

$S_{qice}$  = Ice strength index for blade ice torque

$P_{0,7}$  = propeller pitch at 0,7R

$t_{0,7}$  = max thickness at 0,7 radius

$n$  is the rotational propeller speed, in rpm, at bollard condition. If not known,  $n$  is to be taken as follows:

- $n_n$ , for CP propellers
- $n_n$ , for FP propellers driven by turbine or electric motor
- $0,85 n_n$ , for FP propellers driven by diesel engine,

where  $n_n$  is the nominal rotational speed at MCR free running condition. For CP propellers, propeller pitch  $P_{0,7}$  is to correspond to MCR in bollard condition. If not known,  $P_{0,7}$

is to be taken as  $0,7P_{0,7n}$ , where  $P_{0,7n}$  is propeller pitch at MCR free running condition.

### 3.3.5 Maximum propeller ice thrust applied to the shaft (1/3/2008)

The maximum propeller ice thrust  $T_f$  and  $T_b$ , in kN, are equal to:

Forward:

$$T_f = 1,1 F_f$$

Backwards:

$$T_b = 1,1 F_b$$

## 3.4 Design ice loads for ducted propeller

### 3.4.1 Maximum backward blade force, $F_b$ (1/3/2008)

The maximum backward blade force  $F_b$ , in kN, is equal to:

- when  $D < D_{limit}$

$$F_b = -9,5 S_{ice} \left( \frac{EAR}{Z} \right)^{0,3} [nD]^{0,7} D^2$$

- when  $D \geq D_{limit}$

$$F_b = -66 S_{ice} \left( \frac{EAR}{Z} \right)^{0,3} (nD)^{0,7} D^{0,6} (H_{ice})^{1,4}$$

where:

$D_{limit} = 4 H_{ice}$ , in m

$n$  is to be taken as in [3.3.1].

$F_b$  is to be applied as a uniform pressure distribution to an area on the back side for the following load cases (see Tab 2):

- Load case 1: on the back of the blade from 0,6R to the tip and from the blade leading edge to a value of 0,2 chord length
- Load case 5: for reversible rotation propellers a load equal to 60% of  $F_b$  is applied on the blade face from 0,6R to the tip and from the blade trailing edge to a value of 0,2 chord length.

### 3.4.2 Maximum forward blade force, $F_f$ (1/3/2008)

The maximum forward blade force  $F_f$ , in kN, is equal to:

- when  $D \leq D_{limit}$

$$F_f = 250 \left( \frac{EAR}{Z} \right) D^2$$

- when  $D > D_{limit}$

$$F_f = 500 \left( \frac{EAR}{Z} \right) D \frac{1}{\left(1 - \frac{d}{D}\right)} H_{ice}$$

where:

$$D_{limit} = \frac{2}{\left(1 - \frac{d}{D}\right)} \cdot H_{ice} \quad , \text{ in m}$$

$F_f$  is to be applied as a uniform pressure distribution to an area on the face (pressure) side for the following load cases (see Tab 3):

- a) Load case 3: on the blade face from 0,6R to the tip and from the blade leading edge to a value of 0,5 chord length
- b) Load case 5: a load equal to 60%  $F_f$  is to be applied from 0,6R to the tip and from the blade leading edge to a value of 0,2 chord length.

**3.4.3 Maximum propeller ice torque applied to the propeller (1/3/2008)**

$Q_{max}$  is the maximum torque, in kNm, on a propeller due to ice propeller interaction:

- when  $D \leq D_{limit}$

$$Q_{max} = 74 \left(1 - \frac{d}{D}\right) \left(\frac{P_{0,7}}{D}\right)^{0,16} \left(\frac{t_{0,7}}{D}\right)^{0,6} (nD)^{0,17} S_{qice} D^3$$

- when  $D > D_{limit}$

$$Q_{max} = 141 \left(1 - \frac{d}{D}\right) \left(\frac{P_{0,7}}{D}\right)^{0,16} \left(\frac{t_{0,7}}{D}\right)^{0,6} (nD)^{0,17} S_{qice} D^{1,9} H^{1,1}_{ice}$$

where  $D_{limit} = 1,8 H_{ice}$ , in m

$n$  is the rotational propeller speed, in rps, at bollard condition. If not known,  $n$  is to be taken as follows:

- $n_n$ , for CP propellers
- $n_n$ , for FP propellers driven by turbine or electric motor
- $0,85 n_n$ , for FP propellers driven by diesel engine,

where  $n_n$  is the nominal rotational speed at MCR free running condition.

For CP propellers, propeller pitch  $P_{0,7}$  is to correspond to MCR in bollard condition. If not known,  $P_{0,7}$  is to be taken

as  $0,7P_{0,7n}$ , where  $P_{0,7n}$  is propeller pitch at MCR free running condition.

**3.4.4 Maximum blade spindle torque for CP-mechanism design,  $Q_{smax}$  (1/3/2008)**

Spindle torque  $Q_{smax}$ , in kNm, around the spindle axis of the blade fitting is to be calculated for the load case described in [3.1.1]. If these spindle torque values are less than the default value given below, the latter value, in kNm, is to be used:

Default value  $Q_{smax} = 0,25 F c_{0,7}$

where:

- $c_{0,7}$  is the length of the blade section at 0,7R radius
- $F$  is either  $F_b$  or  $F_f$ , whichever has the greater absolute value.

**3.4.5 Maximum propeller ice thrust (applied to the shaft at the location of the propeller) (1/3/2008)**

The maximum propeller ice thrust  $T_f$  and  $T_b$ , in kN, are equal to:

$T_f = 1,1 F_f$

$T_b = 1,1 F_b$

**3.5 Design loads on propulsion line**

**3.5.1 Torque (1/3/2008)**

The propeller ice torque excitation for shaft line dynamic analysis is to be described by a sequence of blade impacts which are of half sine shape and occur at the blade frequency or at twice to blade frequency (see Fig 1). The torque due to a single blade ice impact as a function of the propeller rotation angle is then:

- when  $\varphi = 0 \dots \alpha_i$   
 $Q(\varphi) = C_q Q_{max} \sin [\varphi (180 / \alpha_i)]$
  - when  $\varphi = \alpha_i \dots 360$   
 $Q(\varphi) = 0$
- where  $C_q$  and  $\alpha_i$  parameters are given in Tab 2.

**Table 2 : Parameters  $C_q$  and  $\alpha_i$**

Torque excitation	Propeller ice interaction	$C_q$	$\alpha_i$
Case 1	Single ice block	0,5	45
Case 2	Single ice block	0,75	90
Case 3	Single ice block	1,0	135
Case 4	Two ice blocks with 45 degree phase in rotation angle	0,5	45

The total ice torque is obtained by summing the torque of single blades taking into account the phase shift  $360^\circ/Z$ . The number of propeller revolutions during a milling sequence is to be obtained with the formula:

$N_Q = 2 H_{ice}$

The number of impacts is  $Z N_Q$ .

See Fig 1.

Milling torque sequence duration is not valid for pulling bow propellers, which are subject to special consideration.

The response torque at any shaft component is to be analysed considering excitation torque  $Q_{(\varphi)}$  at the propeller, actual engine torque  $Q_e$  and mass elastic system.



$Q_e$  = actual maximum engine torque at considered speed

The design torque ( $Q_d$ ) of the shaft component is to be determined by means of torsional vibration analysis of the propulsion line. Calculations are to be carried out for all excitation cases given above and the response is to be applied on top of the mean hydrodynamic torque in bollard condition at the considered propeller rotational speed.

### 3.5.2 Maximum response thrust (1/3/2008)

Maximum thrust along the propeller shaft line is to be calculated with the formulae below. The factors 2,2 and 1,5 take into account the dynamic magnification due to axial vibration. Alternatively, the propeller thrust magnification factor may be calculated by dynamic analysis.

- Maximum shaft thrust forwards  $T_r = T_n + 2,2T_f$
- Maximum shaft thrust backwards  $T_r = 1,5 T_b$

where:

$T_n$  = propeller bollard thrust, in kN

$T_f$  and  $T_b$  = maximum forward and backward propeller ice thrust, in kN

If hydrodynamic bollard thrust,  $T_n$ , is not known,  $T_n$  is to be taken as follows:

- 1,25 T, for CP propellers (open)
- 1,1 T, for CP propellers (ducted)
- T for FP propellers driven by turbine or electric motor
- 0,85 T, for FP propellers driven by diesel engine (open)
- 0,75 T, for FP propellers driven by diesel engine (ducted)

T = nominal propeller thrust at MCR at free running open water condition.

### 3.5.3 Blade failure load for both open and ducted propeller (1/3/2008)

The force is acting at 0,8R in the weakest direction of the blade and at a spindle arm of 2/3 of the distance of the axis of blade rotation of leading and trailing edge, whichever is the greater.

The blade failure load, in kN, is equal to:

$$F_{ex} = \frac{0,3 \cdot c \cdot t^2 \cdot \sigma_{ref}}{0,8 \cdot D - 2 \cdot r} \cdot 10^3$$

where  $\sigma_{ref} = 0,6 \sigma_{0,2} + 0,4 \sigma_u$

and where  $\sigma_u$  and  $\sigma_{0,2}$  are representative values for the blade material, in N/mm<sup>2</sup>.

c, t and r are, in mm, respectively the actual chord length, thickness and radius of the cylindrical root section of the blade at the weakest section outside the root fillet and will typically be at the termination of the fillet into the blade profile.

## 4 Design

### 4.1 Design principle

#### 4.1.1 (1/3/2008)

The strength of the propulsion line is to be designed:

- a) for maximum loads in [3]
- b) such that the plastic bending of a propeller blade will not cause damage to other propulsion line components
- c) with sufficient fatigue strength.

### 4.2 Azimuthing main propulsors

#### 4.2.1 (1/3/2008)

In addition to the above requirements, special consideration is to be given to the loading cases which are extraordinary for propulsion units when compared with conventional propellers. Estimation of the load cases is to reflect the operational realities of the ship and the thrusters. In this respect, for example, the loads caused by impacts of ice blocks on the propeller hub of a pulling propeller are to be considered. Also, loads due to thrusters operating in an oblique angle to the flow are to be considered. The steering mechanism, the fitting of the unit and the body of the thruster are to be designed to withstand the loss of a blade without damage. The plastic bending of a blade is to be considered in the propeller blade position which causes the maximum load on the studied component.

Azimuth thrusters are also to be designed for estimated loads due to thruster body / ice interaction.

### 4.3 Blade design

#### 4.3.1 Maximum blade stresses (1/3/2008)

Blade stresses are to be calculated using the backward and forward loads given in [3.3] and [3.4]. The stresses are to be calculated with recognised and well documented FE-analysis or another acceptable alternative method. The stresses on the blade are not to exceed the allowable stresses  $\sigma_{all}$  for the blade material given below.

Calculated blade stress for maximum ice load is to comply with the following:

$$\sigma_{calc} < \sigma_{all}$$

where  $\sigma_{all} = \sigma_{ref} / S$

$$S = 1,5$$

$\sigma_{ref}$  = reference stress, equal to the minimum of:

$$\sigma_{ref} = 0,7 \sigma_u$$

$$\sigma_{ref} = 0,6 \sigma_{0,2} + 0,4 \sigma_u$$

where  $\sigma_u$  and  $\sigma_{0,2}$  are representative values for the blade material.

#### 4.3.2 Blade edge thickness (1/3/2008)

The blade edge thickness  $t_{ed}$  and tip thickness  $t_{tip}$  are to be greater than  $t_{edge}$ , in mm, given by the following formula:

$$t_{edge} \geq xS \cdot S_{ice} \sqrt{\frac{3p_{ice}}{\sigma_{ref}}}$$

- x : distance from the blade edge, in mm, measured along the cylindrical sections from the edge; this is to be 2,5% of chord length, though need not be taken greater than 45 mm. In the tip area (above 0,975R radius) x is to be taken as 2,5% of 0,975R section length and is to be measured perpendicularly to the edge; however, it is not to be taken greater than 45 mm.
- S : safety factor, to be taken equal to:
- trailing edges:  
S = 2,5
  - leading edges:  
S = 3,5
  - for tip:  
S = 5
- S<sub>ice</sub> : according to [3.2]
- p<sub>ice</sub> : ice pressure, to be taken equal to 16 Mpa for leading edge and tip thickness
- σ<sub>ref</sub> : according to [4.3.1].

The requirement for edge thickness is to be applied for the leading edge and in the case of reversible rotation open propellers also for the trailing edge. Tip thickness refers to the maximum measured thickness in the tip area above 0,975R radius. The edge thickness in the area between position of maximum tip thickness and edge thickness at 0,975 radius is to be interpolated between edge and tip thickness value and smoothly distributed.

#### 4.4 Prime movers

##### 4.4.1 (1/3/2008)

The main engine is to be capable of being started and running the propeller with the CP in full pitch.

##### 4.4.2 (1/3/2008)

Provision is to be made for heating arrangements to ensure ready starting of the cold emergency power units at an ambient temperature applicable to the Polar Class of the ship.

##### 4.4.3 (1/3/2008)

Emergency power units are to be equipped with starting devices with a stored energy capability of at least three consecutive starts at the design temperature in [4.4.2]. The source of stored energy is to be protected to preclude critical depletion by the automatic starting system, unless a second independent means of starting is provided. A second source of energy is to be provided for an additional three starts within 30 min, unless manual starting can be demonstrated to be effective.

### 5 Machinery fastening loading accelerations

#### 5.1 General

##### 5.1.1 (1/3/2008)

Essential equipment and main propulsion machinery supports are to be suitable for the accelerations as indicated below. Accelerations are to be considered acting independently.

### 5.2 Accelerations

#### 5.2.1 Longitudinal Impact Accelerations, a<sub>l</sub> (1/3/2008)

Maximum longitudinal impact acceleration a<sub>l</sub> at any point along the hull girder, in m/s<sup>2</sup>, is equal to:

$$a_l = (F_{IB} / \Delta) \{ [ 1,1 \tan (\gamma + \phi) ] + (7H/L) \}$$

where:

- φ : maximum friction angle between steel and ice, in degrees, normally taken as 10°
- γ : bow stem angle at waterline, in degrees
- Δ : displacement, in t
- L : length between perpendiculars, in m
- H : distance in metres from the waterline to the point being considered, in m
- F<sub>IB</sub> : vertical impact force, defined in Sec 2, [5.2.1], in kN.

#### 5.2.2 Vertical acceleration a<sub>v</sub> (1/3/2008)

Combined vertical impact acceleration at any point along the hull girder, in [m/s<sup>2</sup>]

$$a_v = 2,5 (F_{IB} / \Delta) F_x$$

where:

- F<sub>x</sub> = 1,3 at FP
- F<sub>x</sub> = 0,2 amidships
- F<sub>x</sub> = 0,4 at AP
- F<sub>x</sub> = 1,3 at AP for ships conducting ice breaking astern.
- Intermediate values of F<sub>x</sub> are to be interpolated linearly.

#### 5.2.3 Transverse impact acceleration a<sub>t</sub> (1/3/2008)

Combined transverse impact acceleration at any point along the hull girder, in [m/s<sup>2</sup>]

$$a_t = 3 F_t (F_x / \Delta)$$

where:

- F<sub>x</sub> = 1,5 at FP
- F<sub>x</sub> = 0,25 amidships
- F<sub>x</sub> = 0,5 at AP
- F<sub>x</sub> = 1,5 at AP for ships conducting ice breaking astern.
- Intermediate values of F<sub>x</sub> are to be interpolated linearly.
- F<sub>t</sub> = total force normal to shell plating in the bow area due to oblique ice impact, defined in Sec 2, [4.3.4], in kN.

## 6 Auxiliary systems

### 6.1 General

#### 6.1.1 (1/3/2008)

Machinery is to be protected from the harmful effects of ingestion or accumulation of ice or snow. Where continuous operation is necessary, means are to be provided to purge the system of accumulated ice or snow.

#### 6.1.2 (1/3/2008)

Means are to be provided to prevent damage due to freezing, for tanks containing liquids.

**6.1.3** (1/3/2008)

Vent pipes, intake and discharge pipes and associated systems are to be designed to prevent blockage due to freezing or ice and snow accumulation.

## 7 Sea inlets and cooling water systems

### 7.1 General

**7.1.1** (1/3/2008)

Cooling water systems for machinery that is essential for the propulsion and safety of the ship, including sea chest inlets, are to be designed for the environmental conditions applicable for the additional class notation **POLAR CLASS**.

**7.1.2** (1/3/2008)

At least two sea chests are to be arranged as ice boxes for classes **PC1** to **PC5** inclusive. The calculated volume for each of the ice boxes is to be at least 1m<sup>3</sup> for every 750 kW of the total installed power. For **PC6** and **PC7** there is to be at least one ice box located preferably near the centreline.

**7.1.3** (1/3/2008)

Ice boxes are to be designed for the effective separation of ice and venting of air.

**7.1.4** (1/3/2008)

Sea inlet valves are to be secured directly to the ice boxes. The valve is to be a full bore type.

**7.1.5** (1/3/2008)

Ice boxes and sea bays are to have vent pipes and are to have shut-off valves connected directly to the shell.

**7.1.6** (1/3/2008)

Means are to be provided to prevent freezing of sea bays, ice boxes, ship side valves and fittings above the load waterline.

**7.1.7** (1/3/2008)

Efficient means are to be provided to recirculate cooling seawater to the ice box. The total sectional area of the circulating pipes is not to be less than the area of the cooling water discharge pipe.

**7.1.8** (1/3/2008)

Detachable gratings or manholes are to be provided for ice boxes. Manholes are to be located above the deepest load line. Access is to be provided to the ice box from above.

**7.1.9** (1/3/2008)

Openings in ship sides for ice boxes are to be fitted with gratings, or holes or slots in shell plates. The net area through these openings is to be not less than 5 times the area of the inlet pipe. The diameter of holes or the width of slots in shell plating is to be not less than 20 mm. Gratings of ice boxes are to be provided with a means of clearing. Clearing pipes are to be provided with screw-down type non-return valves.

## 8 Ballast tanks

### 8.1 General

**8.1.1** (1/3/2008)

Efficient means are to be provided to prevent freezing in fore and after peak tanks and wing tanks located above the waterline and where otherwise found necessary.

## 9 Ventilation system

### 9.1 General

**9.1.1** (1/3/2008)

Air intakes for machinery and accommodation ventilation are to be located on both sides of the ship.

**9.1.2** (1/3/2008)

Accommodation ventilation air intakes are to be provided with means of heating.

**9.1.3** (1/3/2008)

The temperature of inlet air provided to machinery from air intakes is to be suitable for safe operation of the machinery.

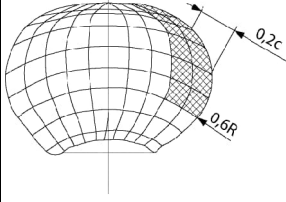
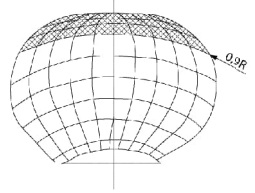
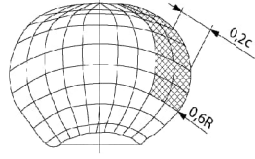
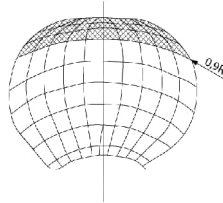
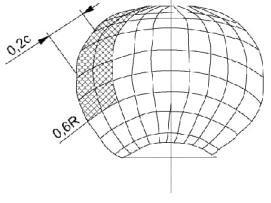
## 10 Alternative design

### 10.1 General

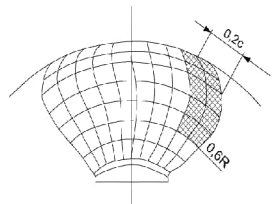
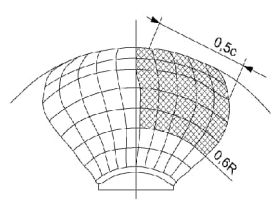
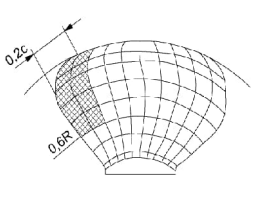
**10.1.1** (1/3/2008)

As an alternative, a comprehensive design study may be submitted with a request for validation by an agreed test program.

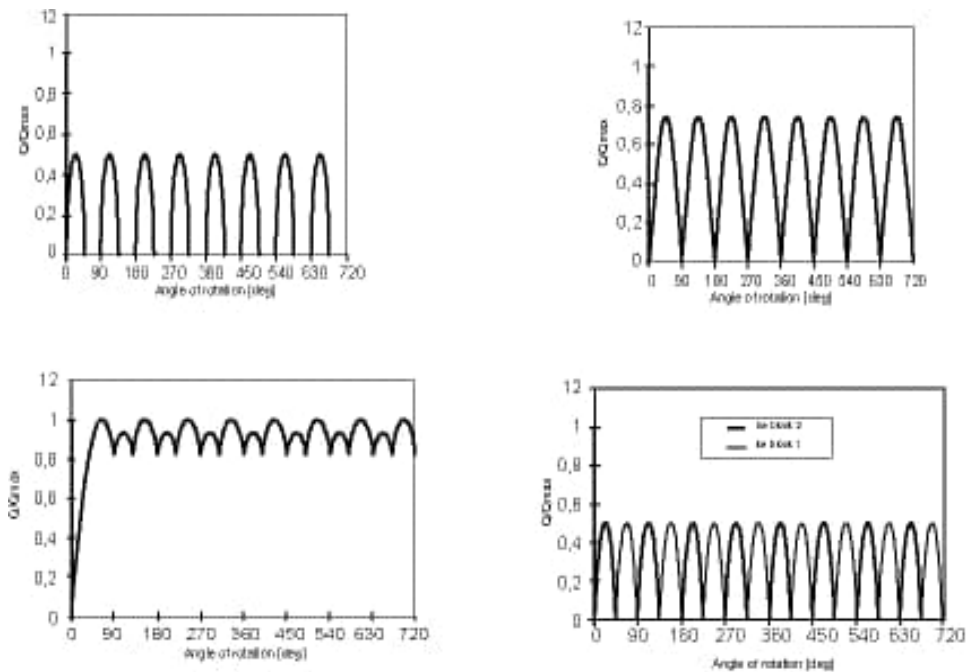
**Table 3 : Load cases for open propeller (1/3/2008)**

	Force	Loaded area	Right handed propeller blade seen from back
Load case 1	$F_b$	Uniform pressure applied on the back of the blade (suction side) to an area from 0,6R to the tip and from the leading edge to 0,2 times the chord length	
Load case 2	50% of $F_b$	Uniform pressure applied on the back of the blade (suction side) on the propeller tip area outside of 0,9R radius	
Load case 3	$F_f$	Uniform pressure applied on the blade face (pressure side) to an area from 0,6R to the tip and from the leading edge to 0,2 times the chord length	
Load case 4	50% of $F_f$	Uniform pressure applied on propeller face (pressure side) on the propeller tip area outside of 0,9R radius	
Load case 5	60 % of $F_f$ or $F_b$ , whichever is the greater	Uniform pressure applied on propeller face (pressure side) to an area from 0,6R to the tip and from the trailing edge to 0,2 times the chord length	

**Table 4 : Load cases for ducted propeller (1/3/2008)**

	Force	Loaded area	Right handed propeller blade seen from back
Load case 1	$F_b$	Uniform pressure applied on the back of the blade (suction side) to an area from 0,6R to the tip and from the leading edge to 0,2 times the chord length	
Load case 3	$F_f$	Uniform pressure applied on the blade face (pressure side) to an area from 0,6R to the tip and from the leading edge to 0,5 times the chord length	
Load case 5	60 % of $F_f$ or $F_b$ , whichever is the greater	Uniform pressure applied on propeller face (pressure side) to an area from 0,6R to the tip and from the trailing edge to 0,2 times the chord length	

**Figure 1 : Shape of the propeller ice torque excitation for 45, 90, 135 degrees single blade impact sequences and 45 degrees double blade impact sequence (two ice pieces) on a four-bladed propeller (1/3/2008)**





Part F  
**Additional Class Notations**

Chapter 11  
**WINTERIZATION**

---

- SECTION 1      GENERAL**
- SECTION 2      HULL AND STABILITY**
- SECTION 3      MACHINERY AND SYSTEMS**
- SECTION 4      ANTI-ICING, DE-ICING, ANTI-FREEZING**





## SECTION 1

## GENERAL

### 1 General

#### 1.1 Purpose and application

##### 1.1.1 (15/11/2007)

The additional class notation **WINTERIZATION (temp)** is assigned, in accordance with Pt A, Ch 1, Sec 2, [6.12.1], to ships intended to be operated in cold climate over long periods.

The value **temp**, in brackets, is the design temperature in °C and is to be taken as the lowest mean daily average air temperature in the area where the ship is intended to operate (see [2]).

### 2 Design temperature

#### 2.1 Definitions

##### 2.1.1 (15/11/2007)

The design temperature (**temp**) is to be taken as the lowest mean daily average air temperature in the area of operation, where:

- Mean: Statistical mean over observation period (at least 20 years)
- Average: Average during one day and night
- Lowest: Lowest during one year.

Fig 1 illustrates the temperature definition.

### 3 Required notations

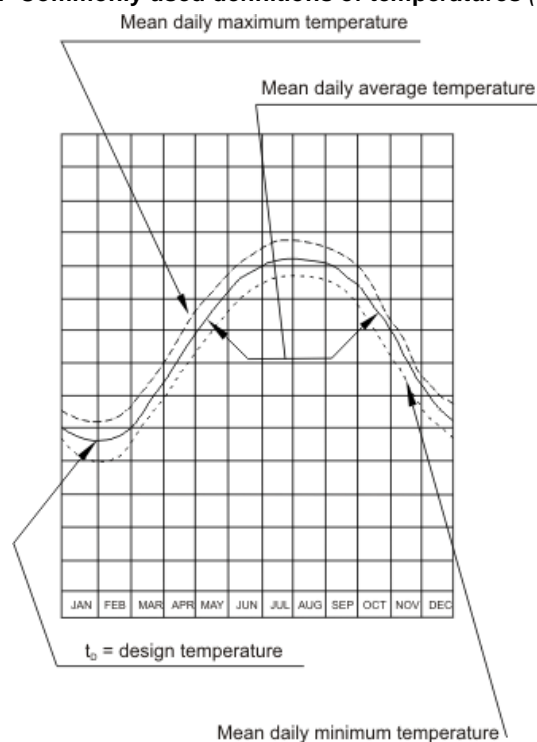
#### 3.1

##### 3.1.1 (15/11/2007)

In order for the **WINTERIZATION (temp)** notation to be granted, the ship is to be assigned the additional class notation **GREEN PLUS** or **GREEN STAR 3 DESIGN** or equivalent and one of the following class notations:

- **POLAR CLASS**
- **ICE CLASS IA SUPER**
- **ICE CLASS IA**
- **ICE CLASS IB**
- **ICE CLASS IC**

**Figure 1 : Commonly used definitions of temperatures (15/11/2007)**



## 4 Documentation to be submitted

### 4.1

#### 4.1.1 (15/11/2007)

Tab 1 lists the documents to be submitted for information or approval.

**Table 1**

No.	I/A (1)	Document
1	I	Manual for anti-icing precautions and de-icing procedures (including arrangement of anti-icing and de-icing equipment for the various areas (heating capacities are to be specified)
2	A	Distribution of steel qualities in structures exposed to low air temperatures
3	A	Trim and stability booklet with ice accretion effects
4	A	Damage stability calculations, when applicable, with ice accretion effects
5	A	Arrangement of the heat tracing systems based on: <ul style="list-style-type: none"> <li>• fluid heating</li> <li>• electrical heating</li> </ul>
6	A	De-icing arrangements of ballast tanks, sea chests
7	A	De-icing arrangements and protection for air intakes
8	A	Deck machinery arrangement (windlasses, winches and deck cranes)
9	A	Diagram of compressed air supply to important consumers outside machinery space
10	A	Diagrams of the steam, hot water, thermal oil piping or other systems used for de-icing purposes
11	A	De-icing devices distribution board
12	A	Arrangement of the equipment located in the machinery spaces, refer to Sec 3, [1.1]
13	A	Test program for anti-icing and de-icing systems
<p>(1) A : to be submitted for approval I : to be submitted for information.</p>		

## SECTION 2

## HULL AND STABILITY

### 1 Structure Design Principles

#### 1.1 Extention of inner hull

##### 1.1.1 (15/11/2007)

In addition to the requirements of the **GREEN STAR 3 DESIGN** notation or equivalent, the inner hull in the cargo area, where fitted, is to be extended within the machinery space as much as possible.

#### 1.2 Materials

##### 1.2.1 (15/11/2007)

The steel grades for structures exposed to low temperatures are to be suitable for the design temperature defined in Sec 1, [2].

#### 1.3 Anchors

##### 1.3.1 (15/11/2007)

The housing arrangement for anchors is to be designed so that icing would not impede the anchor lowering.

The anchor windlass is to be located inside a covered space (deckhouse, or forecastle).

### 2 Stability

#### 2.1 General

##### 2.1.1 (15/11/2007)

Ice accretion effects are to be taken into account in the evaluation of ship stability.

#### 2.2 Intact stability

##### 2.2.1 (1/7/2020)

The stability check is to be carried out in accordance with Pt B, Ch 3, Sec 2, [6] where the values of ice allowances (refer to Pt B, Ch 3, Sec 2, [6.5.1]) are to be taken equal to:

- for decks, gangways, deckhouse tops and other external horizontal surfaces, the values are to be selected from Tab 1;
- for projected lateral (vertical) area of each side of the vessel above the water line: 7.5 kg/m<sup>2</sup>;
- for projected lateral (vertical) area of derrick and other structures located above the water plane: 7.5 kg/m<sup>2</sup>.

The projected lateral area of discontinuous surface of rail, sundry booms, spars (except masts), rigging and other small objects shall be computed by increasing the total projected area of continuous surfaces by 5% and the static moments of this area by 10%.

#### 2.3 Ships with DMS notation

##### 2.3.1 (15/11/2007)

For ships with the notation **DMS** the damage stability calculations are to be carried out in accordance with the applicable requirements of Ch 13, Sec 11 taking into account the ice allowances mentioned in [2.2].

#### 2.4 Subdivision and arrangement

##### 2.4.1 (15/11/2007)

Heating system is to be provided to keep the scuppers free from ice.

**Table 1** (1/7/2020)

Icing load (kg/m <sup>2</sup> ) to be applied to decks, gangways, deckhouse tops and other horizontal surfaces (1)			
	From forward extremity to 50 m aft of F.P.	50 to 100 m aft of F.P.	> 100 m aft of F.P.
> 24 m from W.L.	10	10	10
> 18m to 24 m from W.L.	30	30	30
> 12 to 18 m from W.L. (2)	40	30	30
> 6 to 12 m from W.L. (2)	80	40	30
> 0 to 6 m from W.L. (2)	120	60	30

(1) For the purpose of this Rule, the waterline (WL) shall be taken as the Summer Load Line.  
 (2) For surfaces with active anti-icing systems, the icing weight load in that area may be set to 30 kg/m<sup>2</sup>

## SECTION 3

## MACHINERY AND SYSTEMS

### 1 Propellers

#### 1.1

##### 1.1.1 (15/11/2007)

Controllable pitch propellers are to be adopted, when driven by diesel engines. If the propellers are electrically driven they can be of fixed type, at the condition that the electrical systems can provide 100% of the nominal torque from 100% to 20% of the rpm.

To avoid ice accretion and possible blockage of the propeller rotation, suitable devices (bubble system or periodical propeller rotation by means of a turning gear) or procedures (e.g. changing the blade pitch from time to time) are to be provided.

Highly skewed propellers are to be of controllable pitch type.

### 1.2 Equipment located in the machinery space

#### 1.2.1 (15/11/2007)

The combustion air is to be brought directly to the main and auxiliary engines by means of dedicated ducts in order not to lower machinery spaces temperature.

A pre-heating system for combustion air (by means of electric, steam, water system) is requested unless the internal combustion engine Manufacturer states that the provision above is unnecessary. Additional heating of lube oil is requested for machinery located in the machinery space.

Additional volume of air receivers is to be provided unless the internal combustion engine Manufacturer states that the provision above is unnecessary.

### 2 Heating of spaces

#### 2.1

##### 2.1.1 (15/11/2007)

Heating of machinery spaces is to be provided if thermal balance may lead to low temperatures inside the room.

##### 2.1.2 (15/11/2007)

Special provisions are to be provided for heating and insulation of crew accommodation.

### 3 Windows

#### 3.1

##### 3.1.1 (15/11/2007)

Heated windows to prevent moisture formation and icing are to be provided on the bridge.

### 4 Sea inlets

#### 4.1

##### 4.1.1 (15/11/2007)

Cooling water systems for machinery that are essential for the propulsion and safety of the ship, including sea chests inlets, are to be designed for the environmental conditions applicable to the ice class.

Except if differently provided by the requirements of the notation **POLAR CLASS** (when applicable), one ice box located preferably near centre line is to be arranged, with a calculated volume at least 1m<sup>3</sup> for every 750 kW of the total installed power.

Ice boxes are to be designed for an effective separation of ice and venting of air.

Sea inlet valves are to be secured directly to the ice boxes. The valve is to be of a full bore type.

Ice boxes and sea bays are to have vent pipes and are to have shut off valves connected direct to the shell.

Means are to be provided to prevent freezing of sea bays, ice boxes, ship side valves and fittings above the load water line.

Efficient means are to be provided to re-circulate cooling seawater to the ice box. Total sectional area of the circulating pipes is not to be less than the area of the cooling water discharge pipe.

Detachable gratings or manholes are to be provided for ice boxes. Manholes are to be located above the deepest load line. Access is to be provided to the ice box from above.

Openings in ship sides for ice boxes are to be fitted with gratings, or holes or slots in shell plates. The net area through these openings is to be not less than 5 times the area of the inlet pipe. The diameter of holes and width of slot in shell plating is to be not less than 20 mm. Gratings of the ice boxes are to be provided with a means of clearing. Clearing pipes are to be provided with screw-down type non-return valves.

### 5 Ventilation inlets

#### 5.1

##### 5.1.1 (15/11/2007)

Closing apparatus for ventilation inlets and outlets are to be designed and located to protect them from ice or snow accumulation that could interfere with the effective closure of such systems.

## SECTION 4

## ANTI-ICING, DE-ICING, ANTI-FREEZING

### 1 Anti-icing

#### 1.1 General

##### 1.1.1 (15/11/2007)

Anti-icing arrangement is an arrangement suitable to keep areas free from ice under the ice conditions specified, by means of heating or covering.

Anti-icing arrangement is to be provided with sufficient capacity to keep the equipment or areas free from ice at all times in the service areas and under icing conditions for components that are essential for the ship safety and operation such as:

- navigation
- communication
- watchman location
- steering
- propulsion
- air pipe vent heads for tanks
- scuppers and drains
- anchoring
- emergency towing
- cargo systems and ancillary systems
- fire fighting system
- crew thermal protection
- life saving appliances (including launching devices, heating system of lifeboat engine, storage facilities for life-saving outfit)
- ship whistle
- access way to the bow
- escape exits.

### 2 De-icing

#### 2.1 General

##### 2.1.1 (15/11/2007)

De-icing arrangements are means suitable to remove ice from areas or equipment under the ice conditions specified.

De-icing arrangements are to be provided with sufficient capacity for removal of accreted ice under the icing conditions specified for equipment /areas such as:

- open deck
- gangways/stairways
- superstructures
- railings
- mooring
- outdoor piping
- winches not listed in item [1]
- deck lighting
- helicopter decks.

De-icing arrangements are to be achievable in a limited time (normally 4 to 6 hours), in safe condition for the crew.

The heating power capacity for anti-icing and de-icing arrangements are to be not less than:

- for open deck areas, helicopter decks, gangways, stairways, etc.: 300 W/m<sup>2</sup>
- for superstructures: 200 W/m<sup>2</sup>
- for railings with inside heating: 50 W/m
- for other areas the heating capacity will be considered on a case-by-case basis.

An alarm is to be given when the temperature is below -10°C for 5 hours to inform the crew that the de-icing system is to be put into operation.

### 3 Anti-freezing

#### 3.1 General

##### 3.1.1 (15/11/2007)

Anti-freezing arrangements are arrangements suitable to avoid freezing of liquids under the ice conditions specified.

Anti-freezing arrangements are to be provided for:

- fresh water
- ballast
- fuel oil tanks
- piping systems
- fire extinguishing systems
- water pipes on decks or non-heated spaces
- hydraulic oil systems on decks or non-heated spaces
- life-boat equipment.

## 4 Electric equipment for anti-icing, de-icing, anti-freezing

### 4.1

#### 4.1.1 (15/11/2007)

In the evaluation of the electric load analysis, the power required by the heating arrangements is to be considered as follows:

- 100% of electric power needed for anti-icing and anti-freezing purposes
- 50% of electric power needed for de-icing purposes.

These consumers are to be regarded as essential services.

#### 4.1.2 (15/11/2007)

Distribution switchboards for de-icing equipment are to be provided with indication of the device in service.

#### 4.1.3 Arrangement of electric heating cables (15/11/2007)

In case of electric heating cables, special attention is to be paid to the heat transfer from the cables to the parts to be heated. The cables are to be adequately spaced in order to provide sufficient heating. The fastening of the cables is to be adequate in order to efficiently transmit the heat.

Heating cables are to be short circuit and overload protected. However, self-regulated cables do not require overload protection.

Motors on open deck are to be naturally cooled, i.e. without external fan.

## 5 Arrangements based on heating by fluids

### 5.1

#### 5.1.1 (15/11/2007)

In case of heating by fluids, when calculating the required steam capacity of steam plants or thermal oil heaters, additional capacity is to be considered for anti-icing and

de-icing arrangements applying heating by fluids in pipes, as follows taking:

- 100% of the power consumption for anti-icing and anti-freezing equipment and areas, and
- 50% of the power consumption for de-icing equipment and areas.

When heating is based on fluid heat transfer by means of pipes, special attention is to be paid to the heat transfer from the pipes to the parts to be heated. The pipes are to be adequately spaced in order to provide sufficient heating. The connection of the pipes is to be adequate in order to efficiently transmit the heat to the parts to be heated.

Valves relevant to specific areas or equipment are to be clearly marked with reference to the equipment or area to be heated, and open-closed position of the valves is to be indicated.

Pumps applied for anti-icing purposes are to be arranged with redundancy.

The piping systems for anti-icing and de-icing purposes are also to comply with the requirements in Pt C, Ch 1, Sec 10.

Due regard is to be paid to the piping arrangements to avoid that the heating fluid freezes.

## 6 Testing

### 6.1

#### 6.1.1 (15/11/2007)

Anti-icing, de-icing and anti-freezing systems are to be adequately tested.

## 7 Special equipment

### 7.1

#### 7.1.1 (15/11/2007)

Protective clothing, safety lines, hand tools, crampons for shoes and similar equipment for de-icing purposes are to be kept onboard. The quantity of the equipment is to be sufficient for the assumed extent of manual de-icing.

The equipment for manual de-icing is to be kept in storage facilities and at locations protected from accretion of ice by covers or other anti-icing arrangements.

## **PLANNED MAINTENANCE SYSTEM AND CONDITION BASED MAINTENANCE (PMS/CBM)**

---

- SECTION 1      PLANNED MAINTENANCE SYSTEM**
- SECTION 2      CONDITION BASED MAINTENANCE OF THE PROPULSION  
SYSTEM (PMS-CM(PROP))**
- SECTION 3      CONDITION BASED MAINTENANCE OF THE HEATING  
VENTILATION AND AIR CONDITIONING (PMS-CM(HVAC))**
- SECTION 4      CONDITION BASED MAINTENANCE OF THE CARGO SYSTEM  
(PMS-CM(CARGO))**
- SECTION 5      CONDITION BASED MAINTENANCE OF THE ELECTRICAL  
SWITCHBOARDS (PMS-CM(ELE))**
- SECTION 6      CONDITION BASED MAINTENANCE OF THE FIRE DETECTION  
SYSTEM (PMS-CM(FDS))**
- SECTION 7      CONDITION BASED MAINTENANCE OF MACHINERY ITEMS  
(PMS-CM)**





# SECTION 1

# PLANNED MAINTENANCE SYSTEM

## 1 General

### 1.1 Application

#### 1.1.1 (1/1/2017)

The additional class notation **PMS** is assigned in accordance with Pt A, Ch 1, Sec 2, [6.13.2] to ships with a Planned Maintenance System complying with the requirements of this Section.

#### 1.1.2 (1/1/2017)

A Planned Maintenance System (hereafter referred to as PMS) is a maintenance scheduling and recording system for machinery items which may be considered by the Society as a basis to introduce a Survey scheme which is alternative to the Continuous Machinery Survey system (hereafter referred to as CMS), as described in Pt A, Ch 2, Sec 2, [4.3].

#### 1.1.3 (1/1/2017)

Surveys according to the PMS Survey scheme are to be carried out on the basis of intervals between overhauls recommended by Manufacturers, documented operator's experience and a condition monitoring system, where fitted.

#### 1.1.4 (1/1/2017)

The PMS survey scheme is limited to components and systems covered by CMS.

#### 1.1.5 (1/1/2017)

Any items not covered by the PMS Survey scheme are to be surveyed and credited in the usual way.

#### 1.1.6 (1/1/2017)

The PMS description (see [2.3.1]) may be approved by the Society before the Planned Maintenance Scheme being implemented, at Owner's request.

#### 1.1.7 (1/1/2017)

When the PMS Survey scheme is applied, the scope and periodicity of the class renewal survey are tailored for each individual item of machinery and determined on the basis of recommended overhauls stipulated by the manufacturers, documented experience of the operators and, where applicable and fitted, condition based maintenance (CBM). For instance, within the scope of a PMS the following cases may occur:

- switchboard A is surveyed based on the regular expiry date of the class renewal survey
- lubricating oil pump B is surveyed based on CMS
- diesel engine C is surveyed based on running hours
- turbo pump D is surveyed based on CBM results.

### 1.2 Maintenance intervals

#### 1.2.1 (1/1/2017)

In general, the Survey intervals for items under the PMS Survey scheme are not to exceed those specified for CMS.

However, for components where the maintenance is based on running hours, longer Survey intervals may be accepted as long as the intervals are based on the Manufacturer's recommendations or documented Owners' experience. For items of machinery which are not normally operated (like emergency equipment) the Survey interval may not exceed the one specified for CMS, even if the maintenance is based on running hours.

#### 1.2.2 (1/1/2017)

When the CBM of machinery and components included in the approved PMS Survey scheme shows that their condition and performance are within the allowable limits, no overhaul or Survey is necessary,

### 1.3 Shipboard responsibility

#### 1.3.1 (1/1/2017)

On board the ship there is to be a person responsible for the management of the PMS for the purpose of which he is to possess the appropriate professional qualifications. This person is usually the Chief Engineer; however, another person may be designated by the Owner provided that his qualifications are considered equivalent to those of the Chief Engineer.

The surveys of machinery items and components covered by the PMS may be carried out under the responsibility of the Chief Engineer, by other duly qualified personnel on board, under the conditions and limits given in Pt A, Ch 2, App 1.

#### 1.3.2 (1/1/2017)

Surveys of items overhauls of items covered by the PMS are to be recorded by the person responsible for the management of the PMS.

#### 1.3.3 (1/1/2017)

Access to computerised systems for updating of the maintenance documentation and maintenance program is only to be permitted to the responsible person.

## 2 Conditions and procedures for the approval of the system

### 2.1 General

#### 2.1.1 (1/1/2017)

The Owner is to make a formal request to the Society and provide the PMS description specified in [2.3], in physical or electronic form.

The Society will keep this description for information, unless the Owner requests the Society to approve it.

**2.1.2 (1/1/2017)**

As an alternative to sending the information indicated in [2.3.1], the Owner may grant the Society remote access to its CMMS (see [2.2.1]), which is to include the information requested in [2.3.1].

Information on subsequent amendments to the Scheme, if any, are also to be provided to the Society.

**2.2 System requirements**

**2.2.1 (1/2/2016)**

The PMS is to be programmed and maintained by a Computerised Maintenance Management system (hereafter designated as CMMS) which can be approved by the Society at Owner's request.

**2.2.2 (1/7/2019)**

When a CBM scheme is applied within the PMS, the CMMS is to be able of:

- producing condition reports and maintenance recommendations for the components and systems covered by the CBM scheme;
- identifying where limiting parameters (alarms and warnings) are modified during operation of the CBM scheme;
- assuring continued onboard operation in the event of loss of the communication function, for CBM schemes using remote monitoring and diagnosis (i.e. monitoring data are transferred from the vessel and analyzed remotely).

Software systems can use complex algorithms, machine learning and knowledge of global equipment populations/defect data in order to identify acceptability for continued service or the requirement for maintenance. These systems may be independent of the original equipment manufacturer (OEM) recommended maintenance and condition monitoring suggested limits. Approval of this type of software is to be based on OEM recommendations, industry standards and Society experience.

Where condition monitoring and CBM schemes use remote monitoring and diagnosis (i.e. data is transferred from the vessel and analyzed remotely), the system is to take into account the issues related to cyber safety and security.

**2.2.3 (1/7/2009)**

Computerised systems are to include back-up devices, which are to be updated at regular intervals.

**2.3 PMS Description**

**2.3.1 (1/7/2019)**

The PMS description to be provided to the Society is to include:

- a) a description of the scheme and its application on board, including documentation completion procedures, as well as the proposed organisation chart identifying the areas of responsibility and the people responsible for the PMS on board and ashore, including their qualification
- b) the list of items of machinery and components subject to Machinery Surveys to be considered for classification

in the PMS Survey Scheme, distinguishing for each the principle of survey periodicity used as indicated in [1.1.7]

- c) the procedure for the identification of the items listed in b)
- d) the scope and time schedule of the maintenance procedures for each item listed in b), including acceptable limit conditions of the parameters to be monitored based on the manufacturers' recommendations or recognised standards and laid down in appropriate preventive maintenance sheets
- e) the original baseline data, obtained on board, for machinery undergoing maintenance based on CBM
- f) the list and specifications of the CBM equipment, including the maintenance and CBM methods to be used, the time intervals for maintenance and monitoring of each item and acceptable limit conditions
- g) the baseline data of the machinery checked through CBM
- h) the information flow and pertinent filing procedure
- i) the procedures for carrying out modification to the CMMS and the parameters to be monitored, for the CBM schemes.

**2.3.2 (1/7/2019)**

The following information is to be available on board:

- a) all the information listed in [2.3.1], duly updated
- b) the maintenance instructions for each item of machinery, as applicable (supplied by the manufacturer or by the shipyard)
- c) the CBM data of the machinery, including all data since the last dismantling and the original reference data
- d) reference documentation (trend investigation procedures etc.)
- e) the records of maintenance performed, including conditions found, repairs carried out, spare parts fitted
- f) the list of personnel on board in charge of the PMS management
- g) the records of modification to the CMMS and the parameters to be monitored, for the CBM schemes
- h) the sensors calibration records, for CBM schemes.

**3 Implementation of the system and approval validity**

**3.1**

**3.1.1 (1/2/2016)**

When the information indicated in [2.3.1] is available to the Society, the additional class notation is issued.

**3.1.2 (1/1/2020)**

An implementation survey is to be carried out to confirm the implementation of the Planned Maintenance System (see [4.2]).

At satisfactory outcome of the Implementation Survey, the PMS is intended as approved and the Machinery survey scheme is updated to the PMS Survey scheme.

Subsequently, an annual audit survey is to be carried out to maintain the applicability of the PMS Survey Scheme (see [4.3]).

### 3.1.3 (1/1/2017)

The survey arrangement for machinery under the PMS can be cancelled by the Society if it is apparent that the PMS is not being satisfactorily applied either from the maintenance records or the general condition of the machinery, or when the agreed intervals between overhauls are exceeded.

### 3.1.4 (1/1/2017)

The case of sale or change of management of the ship or transfer of class is to cause the Survey scheme to be reconsidered.

### 3.1.5 (1/1/2017)

The ship Owner may, at any time, cancel the survey arrangement for machinery under the PMS by informing the Society in writing and in this case the items which have been inspected under the PMS Survey scheme since the last annual survey can be credited for class at the next annual survey, at discretion of the attending Surveyor.

## 4 Surveys

### 4.1 Installation Survey

#### 4.1.1 (1/7/2019)

When a CBM scheme is applied within the PMS, condition monitoring equipment are to be installed and surveyed in accordance with the Society's rules, and a set of base line readings is to be taken for the monitoring parameters.

### 4.2 Implementation Survey

#### 4.2.1 (1/7/2019)

The Implementation Survey is to be carried out by the Society's Surveyor within one year from the date of issuance of the PMS notation.

When a CBM scheme is applied within the PMS, the Implementation Survey is to be carried out by the Society's surveyor not earlier than 6 months after the installation survey and not later than the first annual class survey.

#### 4.2.2 (1/7/2019)

The scope of this survey is to verify that:

- the PMS is implemented in accordance with the documentation, including a comparison with the baseline data for CBM schemes, and is suitable for the type and complexity of the components and systems on board
- the information required for the annual audit is produced by the PMS
- the requirements of surveys and testing for retention of class are complied with
- the shipboard personnel are familiar with the PMS procedures and the CBM, if applied
- the CBM data, including baseline data and all data since the last dismantling of the machinery checked through CBM, are stored and managed correctly

- the information and documentation relevant to the hardware and software used, the implementation verifications carried and the results are stored in the ship files
- the records of the limiting parameters (alarms and warnings) modified during the operation of the scheme are available, when a CBM scheme is applied
- the failures' records relevant to components and systems covered by the CBM scheme ensure that the CBM scheme is effective.

#### 4.2.3 (1/1/2020)

When this survey is carried out and the implementation is found in order, the PMS is intended as approved and the survey scheme is updated to the PMS Survey scheme.

### 4.3 Annual Audit of the PMS

#### 4.3.1 (1/7/2019)

An annual audit of the PMS is to be carried out by a Surveyor of the Society and preferably concurrently with the annual survey of machinery.

When a CBM scheme is applied within the PMS, the annual audit of the PMS is to be carried out concurrently with the annual class survey of machinery.

#### 4.3.2 (1/1/2017)

The Surveyor is to check that the personnel on board in charge of the PMS have the appropriate qualifications (see Pt A, Ch 2, App 1).

#### 4.3.3 (1/1/2020)

The purpose of this survey is to verify that the PMS is being correctly operated, in particular that the all items (to be surveyed in the relevant period) have actually been surveyed in due time, and that the machinery has been functioning satisfactorily since the previous survey. A general examination of the items concerned is to be carried out. The availability of the information as per [2.3.2] will be checked.

The missing execution of a Survey or the postponement of a maintenance interval not supported by the relevant manufacturer or by documented Owner's experience is ground for the suspension of the equipment concerned from the PMS Survey scheme; in this case the item concerned is to be made subject to the relevant Renewal Survey, with an interval starting from the last time it was Surveyed under the PMS Survey Scheme.

If the relevant interval has already expired, the Society is to be informed and the item is to be surveyed at the first opportunity, subject to agreement with the Society.

#### 4.3.4 (1/7/2019)

At the discretion of the Surveyor, function tests, confirmatory surveys and random check readings, where condition monitoring equipment is in use shall be carried out as far as practicable and reasonable.

#### 4.3.5 (1/1/2017)

Upon the satisfactory outcome of this survey, the Surveyor confirms the validity of the PMS Survey scheme and decides which items can be credited for class.

## 5 Damage and repairs

### 5.1

#### 5.1.1 (1/7/2019)

Damage to components or items of machinery is to be reported to the Society. The repairs of such damaged components or items of machinery are to be carried out to the satisfaction of the Surveyor.

Where a CBM scheme is applied within the PMS, any machinery part, which has been replaced by a spare one due to damage, is to be retained on board where possible until examined by the Surveyor.

#### 5.1.2 (1/1/2017)

Any repair and corrective action regarding machinery under the PMS Survey scheme is to be recorded in the CMMS and repair verified by the Surveyor at the annual survey.

## 6 Machinery survey in accordance with a Condition Based Maintenance program

### 6.1 Definitions

#### 6.1.1 Condition monitoring (1/7/2019)

Acquisition and processing of information and data that indicate the state of a machine over time. The machine state deteriorates if faults or failures occur.

#### 6.1.2 Diagnostic (1/7/2019)

Examination of symptoms and syndromes to determine the nature of faults or failures.

#### 6.1.3 Condition Based Maintenance (1/7/2019)

Maintenance performed as governed by condition monitoring programmes.

### 6.2 General on Condition Based Maintenance

#### 6.2.1 (1/7/2019)

Condition Based Maintenance (CBM) is the process of extracting prognostic information from machines to indicate their actual wear and degradation and the relevant rate of change (i.e. trend), on the basis of which the maintenance tasks can be adjusted flexibly in accordance to their actual status. The cost effectiveness of the CBM approach is related to the criticality of the monitored items, the reliability of the CBM techniques in providing valuable information and the ease of the interpretation of the results and their trends. In any case, especially for complex machine types, it cannot be expected that CBM can predict the failure mechanism of every component, and opening up will remain the only possible solution to check certain items.

The CBM scheme may be applied to components and systems covered by Continuous Machinery Survey (CMS) system, and other components and systems as requested by the Owner: the choice of the items to be included in the CBM scheme is up to the Owner.

The CBM strategy and its extent are to be approved by the Manufacturer. Parameters acceptability limits are to be based on the Manufacturers' recommendations or recognized standards.

When it is not possible to obtain the Manufacturer's approval on the proposed CBM strategy and extent, the Owner as alternative, is to document the technical background relevant to the proposed CBM strategy and extent (including parameters acceptability limits) and the Society will evaluate the acceptance on a case by case basis, taking into account:

- the criticality of the specific component (for ship and personnel safety) and of the machinery it is part of;
- the expected modes of failure;
- the extent that the proposed strategy addresses the expected modes of failure;
- the evidences used to fix parameters acceptability limits;
- the Owner experience with the specific type of machinery.

Guidance on CBM can be found in the Society "Guide for the Application of Condition Based Maintenance in the Planned Maintenance Scheme".

When intended to cover a whole item of machinery, the minimum parameters to be checked in order to monitor the conditions of the machinery for which this type of maintenance is accepted are indicated in [6.4] and [6.5] for guidance.

The frequency of the measurements can be increased according to the criticality of the equipment.

Other CBM techniques may be accepted if they are proposed or established by the Manufacturer of the equipment to be subjected to monitoring.

Defect and failure data relevant to components and systems covered by the CBM scheme are to be reviewed in order to ensure the proper operation of the CBM scheme or, where necessary, carry out modification to the CBM scheme.

CBM schemes are to identify defects and unexpected failures that were not prevented by the condition monitoring system.

### 6.3 Roles and Responsibilities

#### 6.3.1 Operator (1/7/2017)

At the time of the request for approval of the machinery Planned Maintenance Scheme, the Operator is to submit the CBM details as specified in [6.4] and [6.5] or the alternative proposed strategies, the techniques and the tools that will be employed; for onboard instrumentation, the operating manual and user's guide supplied by the Manufacturer are to be part of the ship's maintenance documentation.

The strategy for the items subjected to CBM is to be computer based and a minimum number of readings is to be taken during the period between annual surveys. CBM does not absolve the machinery personnel of the responsibility to perform visual inspections of the items.

The reading points are to be clearly marked and identified by Memory Identification Card.

The documentation is also to include the responsibility chart of the dedicated human resources for CBM, which may be internal (i.e. shipboard or shoreside staff) or external (professional engineering companies), and the relevant qualifications.

The CBM strategy, inclusive of the description of the tools to be used, dedicated personnel, measurements to be taken etc, is to be an integral part of the PMS survey and is to be included in a dedicated section of the PMS manual.

### 6.3.2 Society (1/1/2008)

The Planned Maintenance Scheme will be reviewed for approval with particular reference to the CBM proposals. The Society reserves the right to require the baseline measurements for a period of at least six months, according to the age and condition of the ship's machinery.

The Society's Surveyors retain the right to test or open up the machinery, irrespective of the presence of CBM, if deemed necessary.

### 6.3.3 Chief Engineer (1/1/2008)

The presence of a CBM does not absolve the Chief Engineer from his duties, including the responsibility for interventions on machines according to his experience and judgment. The Chief Engineer is to ensure that the CBM parameters are recorded at the agreed intervals. This is to include an initial or "baseline" set of readings, against which further data can be compared.

### 6.3.4 Annual survey (1/7/2019)

The requirements for an annual survey of the machinery maintenance and monitoring records are the same as those given in [4.3]. At the annual survey the Chief Engineer is to make available the following maintenance and monitoring records, in addition to those specified in [4.3]:

- CBM records for each item to be credited for class. The records are to indicate where acceptable limits have been exceeded and what actions were taken.
- Calibration certificates for instrumentation used to take measurements, if applicable.

The responsibilities of the Society's Surveyors at the annual survey, additional to those described in [4.3], are:

- a) to examine the machinery and the relevant condition monitoring, performance and maintenance records, including those relevant to the limiting parameters (alarms and warnings) modified since the last survey and to break-down or malfunction, in sufficient depth to ensure that the scheme has been operated correctly and that the machinery has functioned satisfactorily since the previous survey or appropriate action has been taken in response to machinery operating parameters exceeding allowable limits;
- b) to examine the CBM records to verify that the parameters lie within the specified limits (or, in the case of a malfunction in a machine, to check the readings taken just before the malfunction for information to be used in the preparation of the relevant Damage Report). Baseline condition data are to be compared with subsequent readings to ascertain the trend characteristics. The Society's Surveyors may require confirmatory readings on available running machinery to be taken for comparison with the ship's records.
- c) to check the calibration status for CBM instrumentation (sensor, equipment, etc.);
- d) verify the crew's familiarity with the CBM scheme, the relevant tools and records;
- e) to verify that the suitability of the CBM scheme has been reviewed following defects and failures of the components and systems covered by CBM.

## 6.4 CBM criteria for main machinery

### 6.4.1 (1/1/2020)

This section indicates the principles to apply when a whole piece of equipment has to be fully monitored by CBM. Individual items have to be approached on a case-by-case basis, according to the criteria of [6.2.1].

### 6.4.2 Diesel engines for propulsion and main electrical generation (1/1/2008)

Tab 1 lists the minimum checks to be carried out according to the engine service.

Table 1 (1/7/2008)

Parameters to be monitored	Diesel engine (single or dual fuel) for direct main propulsion		Diesel engine for electric power generation	
	Request	Minimum periodicity	Request	Minimum periodicity
Power output (1)	Yes	Weekly	Yes	Weekly
Running hours	Yes	Weekly	Yes	Weekly
Rotational speed	Yes	Weekly	Yes	Weekly
Indicated pressure diagram (where possible) or pressure-time curves	Yes	Weekly	Yes	Weekly
Fuel oil temperature and/or viscosity	Yes	Weekly	Yes	Weekly
Charge air pressure and temperature at receiver	Yes	Weekly	Yes	Weekly
Exhaust gas temperature for each cylinder	Yes	Weekly	No	-
Exhaust gas temperature before and after the turbochargers	Yes	Weekly	Yes	Weekly
Temperatures and pressure of engine cooling system	Yes	Weekly	Yes	Weekly
Temperatures and pressure of engine lube oil system	Yes	Weekly	Yes	Weekly
Rotational speed of turbochargers (2)	Yes	Weekly	Yes	Weekly
Bearing vibrations of turbochargers (2)	Yes	Monthly	Yes	Monthly
Results of lube oil analysis	Yes	3 months	Yes	6 months
Crankshaft deflection readings	Yes	6 months	Yes	6 months
Analysis of the fluid of crankshaft torsional vibration damper (if viscous type) according to maker's instructions	Yes	6 months or as per maker's instruction	Yes	6 months or as per maker's instruction
Temperature of main bearings and crankcase pressure	Yes	Weekly Where available	Yes	Weekly Where available
Fuel oil analysis (ISO 8217:2005)	Yes	At every bunkering	Yes	At every bunkering
Engine load (%)	No	-	Yes	Weekly
Alternator load (kW)	No	-	Yes	Weekly
<p>(1) To be read by a torquemeter or other equivalent instrument, or through the governor output, or by taking the position of the rack</p> <p>(2) Reading points of turbocharger's rotational speed and bearing vibrations are to be identified according to the Manufacturer's instructions</p> <p><b>Note 1:</b> If the Owner opts to monitor the turbocharger(s) independently of the diesel engine, the following measures are to be taken on a weekly basis as a minimum:</p> <ul style="list-style-type: none"> <li>• Exhaust gas temperature before/after turbocharger</li> <li>• Charge air pressure at receiver</li> <li>• Turbocharger rotational speed and vibration.</li> </ul> <p>Reading points are to be identified according to the Manufacturer's instructions.</p>				

Parameters to be monitored	Diesel engine (single or dual fuel) for direct main propulsion		Diesel engine for electric power generation	
	Request	Minimum periodicity	Request	Minimum periodicity
Inspection of bedplate structure/ chocks / down bolts	Yes	6 months	Yes	6 months
Vibration of bearings of diesel generator and alternator	No	-	Yes	4 months
<p>(1) To be read by a torquemeter or other equivalent instrument, or through the governor output, or by taking the position of the rack</p> <p>(2) Reading points of turbocharger's rotational speed and bearing vibrations are to be identified according to the Manufacturer's instructions</p> <p><b>Note 1:</b> If the Owner opts to monitor the turbocharger(s) independently of the diesel engine, the following measures are to be taken on a weekly basis as a minimum:</p> <ul style="list-style-type: none"> <li>Exhaust gas temperature before/after turbocharger</li> <li>Charge air pressure at receiver</li> <li>Turbocharger rotational speed and vibration.</li> </ul> <p>Reading points are to be identified according to the Manufacturer's instructions.</p>				

#### 6.4.3 Emergency diesel generator (1/1/2008)

The parameters to be checked are the following:

- calibration and test of fuel nozzles
- measurement of compression of cylinders
- fuel oil filter cleaning
- lube oil analysis.

The measures are to be taken at five-year intervals as a minimum.

#### 6.4.4 Electric propulsion motor with associated frequency converter (1/1/2008)

Tab 2 lists the minimum checks to be carried out.

**Table 2 (1/1/2008)**

Method	Requirement
Performance Monitoring	Propulsion Motor: Continuous or periodical monthly monitoring of: <ul style="list-style-type: none"> <li>• Supplying current on main switchboard (phases and windings)</li> <li>• Converter current (phases and windings)</li> <li>• Feeding transformer highest winding temperature</li> <li>• Motor highest winding temperature</li> <li>• Rotational speed</li> <li>• Encoder for rotor position check</li> <li>• Bearing temperature at drive end (D.E.)</li> <li>• Bearing temperature at non-drive end (N.D.E.)</li> <li>• Cooling air in temperature</li> <li>• Cooling air out temperature</li> <li>• Highest cubicle temperature</li> <li>• Converter heat exchanger temperatures</li> <li>• Motor D.E. and N.D.E. oil leakage detection</li> </ul> Propulsion system insulation resistance: every 12 months
Vibration Monitoring	Periodical monitoring of motor bearings. No less than one per month
Lubricant Analysis	Regular sampling, laboratory testing. No less than one sampling every 6 months
Oil Transformer analysis	Regular sampling, laboratory testing. No less than one sampling every 6 months

**6.4.5 Pods with associated frequency converter**  
(1/1/2008)

Tab 3 lists the minimum checks to be carried out.

**Table 3 (1/1/2008)**

Method	Requirement
Performance Monitoring	Propulsion Motor: Continuous or periodical monthly monitoring of: <ul style="list-style-type: none"> <li>• Supplying current on main switchboard (phases &amp; windings)</li> <li>• Converter current (phases &amp; windings)</li> <li>• Feeding transformer highest winding temperature</li> <li>• Motor highest winding temperature</li> <li>• Rotational speed</li> <li>• Encoder for rotor position checking, including gears, if any</li> <li>• Pod propeller bearing temperature</li> <li>• Pod thrust bearing temperature</li> <li>• Cooling air in temperature</li> <li>• Cooling air out temperature</li> <li>• Highest cubicle temperature</li> <li>• Converter heat exchanger temperatures</li> <li>• Pod propeller end - thrust end bearings, oil/water contamination recorded value</li> <li>• Pod slewing sealing oil/grease leaking recorded value</li> <li>• Pod steering check of pump working pressure/current</li> <li>• Propulsion system insulation resistance (every 12 months)</li> </ul>
Vibration Monitoring	Periodical or continuous monitoring of motor bearings. No less than one per month
Lubricant Analysis	Regular sampling, laboratory testing. No less than one sampling every 6 months. Alternatively, a fixed analyser allowing continuous oil debris monitoring can be fitted in the section from the oil return line to the filter, provided that it does not affect the oil flow in any way
Oil Transformer analysis	Regular sampling, laboratory testing. No less than one sampling every 6 months



**6.4.6 Gas turbines (1/1/2008)**

Tab 4 lists the minimum checks to be carried out. The periodicity of the measures is to be defined by the Manufacturer. In addition, shut-down systems and safety devices are to be checked at Annual Survey.

**6.4.7 Tailshaft (1/1/2008)**

The requirements as per the additional class notation **MON-SHAFT** ( Ch 5, Sec 2) apply. In addition, a visual inspection

of flexible joints is to be carried out regularly, at the same periodicity set forth in Ch 5, Sec 2, [2.2.2], to check the following items:

- Static deformation
- Oxidation/ageing of the elastic rubber element
- Detachment of rubber/metal joining
- Surface cracks in the elastic rubber element.

**Table 4 (1/1/2008)**

Method	Requirement
Visual Inspection	Periodical inspection of : <ul style="list-style-type: none"> <li>• intakes and exhaust ducts</li> <li>• inlet guide vanes</li> <li>• compressor (first stage)</li> <li>• casings</li> <li>• auxiliaries</li> <li>• running clearances (as far as practicable)</li> </ul>
Borescope	Periodical inspection of : <ul style="list-style-type: none"> <li>• compressor stators</li> <li>• guide vanes and blades</li> <li>• combustion chambers</li> <li>• turbine nozzles and blades</li> </ul>
Vibration Monitoring	Continuous monitoring and trend analysis of gas turbine rotor bearing vibration
Lubricant Analysis	Periodical inspection of : <ul style="list-style-type: none"> <li>• magnetic particle detectors</li> <li>• oil filters</li> </ul> Regular sampling of lube oil, laboratory testing Alternatively, a fixed analyser allowing continuous oil debris monitoring can be fitted in the section from the oil return line to the filter, provided that it does not affect the oil flow in any way
Fuel analysis	Regular sampling according to ISO 8217: 2005
Performance monitoring (usually provided by the automation system associated with the package)	Continuous monitoring and trend analysis of : <ul style="list-style-type: none"> <li>• compressor (inlet/exit temperature, discharge pressure, speed)</li> <li>• turbine (inlet temperature, speed)</li> <li>• engine breather temperature</li> <li>• fatigue counter</li> </ul>

**6.4.8 Gearing (1/1/2008)**

Tab 5 lists the minimum checks to be carried out.

**Table 5 (1/1/2008)**

Method	Requirement
Condition Monitoring	Gear wheels, pinions, shafts, bearings, couplings, power clutch and driven pumps are to be inspected at every dismantling. The following checks are required: <ul style="list-style-type: none"> <li>• gear backlash and pinion/shaft diametric clearance</li> <li>• shaft seal tightness.</li> </ul> It may be accepted that gears and roller bearings are inspected without dismantling, as far as practicable, by means of non-invasive diagnostic techniques. Moreover, the following parameters are to be checked weekly: <ul style="list-style-type: none"> <li>• bearing lubricating oil pressure</li> <li>• rotational speed.</li> </ul>
Vibration Monitoring	Periodical or continuous monitoring of bearings. No less than once every 4 months
Lubricant Analysis	Regular sampling, laboratory testing. No less than one sampling every 6 months

**6.4.9 Shaft generator (1/1/2008)**

Periodical or continuous monitoring of bearings is requested, no less than once per month.

**6.4.10 Steam turbines (1/1/2008)**

For the main and auxiliary steam turbines the parameters to be checked are the following:

- turbine bearing vibrations (continuous or monthly readings)
- power output (by torquemeter or other equivalent device; otherwise the number of nozzles, the inlet steam pressure and the pressure in the nozzle chamber are to be available for the power appraisal) (continuous or weekly readings)
- Rotational speed (continuous or weekly readings)
- Periodical measurement of rotor axial position using external indicators (monthly)
- Continuous or periodical monthly vibration monitoring of turbine bearing housing
- Plant performance data, i.e. steam conditions at the inlet and outlet of each turbine, saturated, superheated and desuperheated steam conditions at the outlet of boilers, condenser vacuum, sea temperature.

Lube oil analysis is requested at least once every six months.

The following additional visual inspections or checks are required:

- boiler water analysis records every six months
- inspection of rotor bearings, thrust bearings, coupling and casing axial expansion arrangements at every dismantling
- inspection of final low pressure and astern blading at every dismantling.

**6.5 Miscellaneous systems and equipment**

**6.5.1 General (1/1/2008)**

This item [6.5] summarises the minimum requirements for the most common machinery types that can be fitted on ships. In addition to the listed parameters to be checked, periodical visual inspections are to be scheduled.

**6.5.2 Cooling system equipment: centrifugal pumps, electric motor driven (1/1/2008)**

Periodical check of:

- rotational speed
- vibration monitoring with associated readings
- pressure at suction/delivery
- electric motor current.

Note 1: for engine driven pumps, vibration readings are always to be taken at the same engine speed (rpm).

Minimum frequency of checks:

- monthly: sea water cooling pumps, high and low temperature fresh water cooling pumps, general service low temperature pumps
- every four months: preheating high temperature cooling system pumps.

**6.5.3 Lubrication oil system: worm/gear pumps, electric motor driven (1/1/2008)**

Periodical check of:

- rotational speed
- vibration monitoring with associated readings
- pressure at suction/delivery
- electric motor current.

Note 1: for engine driven pumps, vibration readings are always to be taken at the same engine speed (rpm).

Minimum frequency of checks: monthly.

**6.5.4 Fuel oil system: booster/supply gear pumps, electric motor driven (1/1/2008)**

Periodical check of:

- rotational speed
- vibration monitoring with associated readings
- pressure at suction/delivery
- electric motor current.

Note 1: for engine driven pumps, vibration readings are always to be taken at the same engine speed (rpm).

Minimum frequency of checks: monthly.

**6.5.5 Compressed air system (1/1/2008)**

For the following machine types:

- starting air compressor, reciprocating, electric motor driven
- general service air compressor, piston/screw type, electric motor driven
- auxiliary blower electric motor driven,

periodical check of:

- rotational speed
- vibration monitoring with associated readings
- delivery pressure
- electric motor current,

are required.

Minimum frequency of checks: every three months.

**6.5.6 Steering gear system: hydraulic pumps, electric motor driven (1/1/2008)**

The following checks are required, on a monthly basis as a minimum:

- rotational speed
- vibration monitoring, (continuous or periodical readings)
- zero positioning check
- flexible hose check.

**6.5.7 Purifying system : fuel oil and lube oil purifiers (1/1/2008)**

The following checks are required:

- on a monthly basis as a minimum:
  - vibration monitoring at reading point indicated by maker (vibration limits suggested by Manufacturer, because of high speed)
  - bowl rotational speed reading
- every three months as a minimum:
  - vibration monitoring periodical readings and visual inspection of fuel oil or lube oil supply gear pumps.

**6.5.8 Miscellaneous liquid transfer pumps (1/1/2008)**

For the following equipment types, electric motor driven:

- fuel oil transfer pumps (worm, gears)
- fresh water transfer pumps (centrifugal)
- lube oil transfer pumps (worm, gears),

the following checks are required, at least every three months:

- vibration monitoring with associated readings
- suction/delivery pressure
- electric motor current
- rotational speed.

**6.5.9 Ballast, fire and general service pumps (1/1/2008)**

For the following equipment types, electric motor driven:

- ballast pumps (centrifugal)
- fire pumps (centrifugal)
- general service pumps (centrifugal),

the following checks are required, at least every three months and as far as possible in the same working conditions:

- vibration monitoring with associated readings
- suction/delivery pressure
- electric motor current
- rotational speed.

**6.5.10 Bilge system (1/1/2008)**

For the following equipment types, electric motor driven:

- centrifugal pumps
- reciprocating pumps,

the following checks are required, at least on a monthly basis and as far as possible in the same working conditions:

- vibration monitoring with associated readings
- suction/delivery pressure
- electric motor current
- rotational speed.

**6.5.11 Potable water system of passenger ships: centrifugal pumps, electric motor driven (1/1/2008)**

The following checks are required, at least every three months and as far as possible in the same working conditions:

- vibration monitoring with associated readings
- suction/delivery pressure
- electric motor current
- rotational speed.

**6.5.12 Manoeuvring equipment: bow and stern thrusters, electric motor driven (1/1/2008)**

The following checks are required, at least every three months:

- vibration monitor readings of electric motor
- electric motor current to be recorded
- rotational speed
- vibration monitor readings and visual inspection of servo unit pumps of thrusters.

### 6.5.13 Steam system (1/1/2008)

For the following equipment type:

- main boiler feed water multistage centrifugal pumps, steam turbine driven,

the following checks are required, at least every three months:

- rotational speed,
- steam pressure/temperature at turbine inlet/outlet
- pump suction/delivery pressure
- lubricating oil analysis
- pump and turbine bearing vibration monitoring.

For the following equipment types, electric motor driven:

- auxiliary boiler feed water, single stage or multistage centrifugal pumps
- exhaust boiler circulating centrifugal pumps
- fuel oil pumps of main and auxiliary boilers
- boiler forced draught ventilators, electric motor driven,

the following checks are required, at least every three months, as far as possible in the same working conditions:

- vibration monitoring with associated readings
- suction/delivery pressure
- electric motor current
- rotational speed.

For the following equipment type, electric motor driven:

- boiler forced draught ventilators, electric motor driven,

the following checks are required, at least every three months, as far as possible in the same working conditions:

- vibration monitoring with associated readings
- electric motor current.

### 6.5.14 Fresh water generator (1/1/2008)

For the following equipment type, electric motor driven:

- feed, cooling, injector sea water centrifugal pumps

the following checks are required, at least on a monthly basis:

- vibration monitoring with associated readings
- rotational speed
- electric motor current
- suction/delivery pressure.

The above checks also apply for distillate and condensate centrifugal pumps, at least every three months.

### 6.5.15 Air conditioning and refrigeration system (1/1/2008)

For the following equipment type, electric motor driven:

- screw, piston or centrifugal compressor for HVAC, electric motor driven, direct or belt transmission,

the following checks are required, at least every three months:

- vibration monitoring with associated readings
- rotational speed
- electric motor current
- suction/delivery pressure.

### 6.5.16 Oil tanker systems (1/1/2008)

For centrifugal large size cargo pumps, electric motor or steam turbine driven, the following checks are required, at least every three months:

- vibration monitoring with associated readings
- rotational speed
- electric motor current
- suction/delivery pressure.

The ship loading conditions and draught are to be recorded.

Note 1: the instruments employed are to be intrinsically safe.

For inert gas blowers (radial, centrifugal or rotary), electric motor driven, the following checks are required, at least on a monthly basis:

- vibration monitoring with associated readings
- rotational speed
- electric motor current.

### 6.5.17 Ventilation system (1/1/2008)

For ventilators, the following checks are required, at least every three months:

- vibration monitoring with associated readings
- rotational speed
- electric motor current.

Note 1: the following equipment may be difficult to reach and may require remote installations with cables placed outside:

- HVAC units of accommodation systems
- ventilators of various type for engine rooms, pump room, stores, purifier room with ventilator on shaft
- ventilators for evacuating exhaust from ro-ro car spaces.

### 6.5.18 Chemical tanker systems (1/1/2008)

For the following components of hydraulic power packs:

- supply pumps for hydraulic power packs
- hydraulic cargo pumps
- hydraulic pump for servo units,

the following checks are required, at least every three months:

- vibration monitoring with associated readings
- electric motor current
- suction/delivery pressure.

The ship loading conditions and draught are to be recorded.

Note 1: the instruments are to be intrinsically safe; moreover, if the cargo pumps are submerged, a fixed installation is to be provided to allow vibration readings from a remote position.

### 6.5.19 Liquefied gas carrier systems (1/1/2008)

For compressors of the refrigerating cycle, electric motor driven, the following checks are required, at least every three months:

- vibration monitoring with associated readings
- electric motor current
- suction/delivery pressure.

**6.5.20 Refrigerated cargo ship systems (1/1/2008)**

For compressors screw or piston type, electric motor driven, the following checks are required, at least every three months:

- vibration monitoring with associated readings
- electric motor current
- suction/delivery pressure.

**6.5.21 Electrical switchboard (1/1/2008)**

For low voltage panels and medium voltage panels (if practicable), a thermographic inspection is required at least yearly, in the conditions of maximum expected load. The same techniques may also be applied to cables, piping or even to machinery parts to extract information additional to the other CBM techniques.

## SECTION 2

# CONDITION BASED MAINTENANCE OF THE PROPULSION SYSTEM (PMS-CM(PROP))

### 1 General

#### 1.1 Application

##### 1.1.1 (1/7/2009)

The additional class notation **PMS-CM(PROP)** is assigned to ships classed by the Society, eligible for the PMS additional class notation as per Sec 1 and complying with the requirements of this Section.

In the event that the ship undergoes modifications, refitting or repairs that may affect the machinery previously subject to Condition Based Maintenance (CBM), the retention of the notation is subject to the results of new measurements as deemed appropriate by the Society.

#### 1.2 Scope of PMS-CM(PROP) Notation

##### 1.2.1 (1/7/2009)

The notation is assigned if CBM in accordance with the criteria laid down in Sec 1, [6] is applied to equipment that is essential for the continuous operation of the propulsion system. Such equipment is to include, as applicable, the main engine, coupling, and main shaft. Piping, pressure vessels and electrical cables can be surveyed in the usual way. The result of the survey is to be recorded and kept together with the CBM results.

#### 1.3 Documentation for Approval

##### 1.3.1 (1/7/2009)

The documentation for the CBM is to be in accordance with the requirements of Sec 1, [6.3]; in particular, the scope of the application is to be clearly illustrated. The CBM criteria to follow for each piece of machinery are laid out in Sec 1, [6.4] and Sec 1, [6.5]. Equipment not included therein will be the subject of special consideration.

#### 1.4 Implementation of the CBM

##### 1.4.1 (1/7/2009)

When the documentation submitted has been approved and the CBM has been implemented on board and used for a sufficient period (which is not to exceed one year) to allow the personnel to become familiar with it, a survey is to be carried out, in order to make the system officially operational, by a Surveyor of the Society or by another certified society.

##### 1.4.2 (1/7/2009)

Upon the successful outcome of this survey, the CBM is considered approved.

#### 1.5 Surveys

##### 1.5.1 (1/7/2009)

The same requirements laid out in Sec 1, [5] and Sec 1, [6] are valid, as applicable.

## SECTION 3

# CONDITION BASED MAINTENANCE OF THE HEATING VENTILATION AND AIR CONDITIONING (PMS-CM(HVAC))

## 1 General

### 1.1 Application

#### 1.1.1 (1/7/2009)

The additional class notation **PMS-CM(HVAC)** is assigned to ships classed by the Society, eligible for the PMS additional class notation as per Sec 1 and complying with the requirements of this Section.

In the event that the ship undergoes modifications, refitting or repairs that may affect the machinery previously subject to Condition Based Maintenance (CBM), the retention of the notation is subject to the results of new measurements as deemed appropriate by the Society.

### 1.2 Scope and requirements of PMS-CM(HVAC) Notation

#### 1.2.1 (1/7/2009)

The notation is assigned if CBM in accordance with the criteria laid down in Sec 1, [6] is applied to equipment that is essential for the continuous operation of the HVAC system. Such equipment is to include HVAC compressors and ventilators comprising electric motors and transmission. Heat exchangers, piping, pressure vessels and valves can be surveyed in the usual way. The result of the survey is to be recorded and kept together with the CBM results.

### 1.3 Documentation for Approval

#### 1.3.1 (1/7/2009)

The documentation for the CBM is to be in accordance with the requirements of Sec 1, [6.3]; in particular, the scope of the application is to be clearly illustrated. The CBM criteria to follow for each piece of machinery are laid out in Sec 1, [6.4] and Sec 1, [6.5]. Equipment not included therein will be the subject of special consideration.

### 1.4 Implementation of the CBM

#### 1.4.1 (1/7/2009)

When the documentation submitted has been approved and the CBM has been implemented on board and used for a sufficient period (which is not to exceed one year) to allow the personnel to become familiar with it, a survey is to be carried out, in order to make the system officially operational, by a Surveyor of the Society or by another certified society.

#### 1.4.2 (1/7/2009)

Upon the successful outcome of this survey, the CBM is considered approved.

### 1.5 Surveys

#### 1.5.1 (1/7/2009)

The same requirements laid out in Sec 1, [5] and Sec 1, [6] are valid, as applicable.

## SECTION 4

# CONDITION BASED MAINTENANCE OF THE CARGO SYSTEM (PMS-CM(CARGO))

### 1 General

#### 1.1 Application

##### 1.1.1 (1/7/2009)

The additional class notation **PMS-CM(CARGO)** is assigned to ships classed by the Society, eligible for the PMS additional class notation as per Sec 1 and complying with the requirements of this Section.

In the event that the ship undergoes modifications, refitting or repairs that may affect the machinery previously subject to Condition Based Maintenance (CBM), the retention of the notation is subject to the results of new measurements as deemed appropriate by the Society.

#### 1.2 Scope and requirements of PMS-CM(CARGO) Notation

##### 1.2.1 (1/7/2009)

The notation is assigned if a CBM program in accordance to the criteria laid down in Sec 1, [6] is applied to equipment that is essential for the operation of the cargo system of tankers. Such equipment is to include, as applicable, cargo pumps and their prime movers, power packs and remotely operated valves; the latter are to be tested periodically (at least every three months) to ascertain their functionality and tightness. Piping, pressure vessels and valves can be surveyed in the usual way. The result of the survey is to be recorded and kept together with the CBM results.

#### 1.3 Documentation for Approval

##### 1.3.1 (1/7/2009)

The documentation for the CBM is to be in accordance with the requirements of Sec 1, [6.3]; in particular, the scope of the application is to be clearly illustrated. The CBM criteria to follow for each piece of machinery are laid out in Sec 1, [6.4] and Sec 1, [6.5]. Equipment not included therein will be the subject of special consideration.

#### 1.4 Implementation of the CBM

##### 1.4.1 (1/7/2009)

When the documentation submitted has been approved and the CBM has been implemented on board and used for a sufficient period (which is not to exceed one year) to allow the personnel to become familiar with it, a survey is to be carried out, in order to make the system officially operational, by a Surveyor of the Society or by another certified society.

##### 1.4.2 (1/7/2009)

Upon the successful outcome of this survey, the CBM is considered approved.

#### 1.5 Surveys

##### 1.5.1 (1/7/2009)

The same requirements laid out in Sec 1, [5] and Sec 1, [6] are valid, as applicable.



## SECTION 5

# CONDITION BASED MAINTENANCE OF THE ELECTRICAL SWITCHBOARDS (PMS-CM(ELE))

### 1 General

#### 1.1 Application

##### 1.1.1 (1/7/2009)

The additional class notation **PMS-CM(ELE)** is assigned to ships classed by the Society, eligible for the PMS additional class notation as per Sec 1 and complying with the requirements of this Section.

In the event that the ship undergoes modifications, refitting or repairs that may affect the items previously subject to Condition Based Maintenance (CBM), the retention of the notation is subject to the results of new measurements as deemed appropriate by the Society.

#### 1.2 Scope and requirements of PMS-CM(ELE) Notation

##### 1.2.1 (1/7/2009)

The notation is assigned if a CBM program in accordance to the criteria laid down in Sec 1, [6] is applied to electrical switchboards above 100 kW.

#### 1.3 Documentation for Approval

##### 1.3.1 (1/7/2009)

The documentation for the CBM is to be in accordance with the requirements of Sec 1, [6.3]; in particular, the scope of

the application is to be clearly illustrated. The CBM criteria to follow for each piece of machinery are laid out in Sec 1, [6.4] and Sec 1, [6.5]. Equipment not included therein will be the subject of special consideration.

#### 1.4 Implementation of the CBM

##### 1.4.1 (1/7/2009)

When the documentation submitted has been approved and the CBM has been implemented on board and used for a sufficient period (which is not to exceed one year) to allow the personnel to become familiar with it, a survey is to be carried out, in order to make the system officially operational, by a Surveyor of the Society or by another certified society.

##### 1.4.2 (1/7/2009)

Upon the successful outcome of this survey, the CBM is considered approved.

#### 1.5 Surveys

##### 1.5.1 (1/7/2009)

The same requirements laid out in Sec 1, [5] and Sec 1, [6] are valid, as applicable.

## SECTION 6

# CONDITION BASED MAINTENANCE OF THE FIRE DETECTION SYSTEM (PMS-CM(FDS))

### 1 General

#### 1.1 Application

##### 1.1.1 (1/7/2009)

The additional class notation **PMS-CM(FDS)** is assigned to ships classed by the Society, eligible for the PMS additional class notation as per Section 1 and complying with the requirements of this Section.

In the event that the ship undergoes modifications, refitting or repairs that may affect the items previously kept subject to Condition Based Maintenance (CBM), the retention of the notation is subject to the results of new measurements as deemed appropriate by the Society.

#### 1.2 Scope and requirements of PMS-CM(FDS) Notation

##### 1.2.1 (1/7/2009)

The notation is assigned if CBM is applied to fire control panels and fire sensors (FDS).

System faults in the control panels, their peripherals and the networking system (if any) and sensors are to be logged and reported.

In addition to the fault messages generated by the event, the FDS is to:

- log the performance and the response of the sensors at least [once a day] [every 6 hours],
- evaluate the drift of the sensor reading due to external factors (pollution),
- predict possible faults due to the environmental conditions.

The results of the CBM evaluations are to be stored in the CBM system itself and to generate automatically the lists of the predicted faulty units for maintenance purposes.

A full list of the system conditions, as well as statistical data about sensors, divided into groups (e.g. good conditions, close to fault, faulty due to..) are to be generated by the system in order to provide means for quick checking both by Surveyors and authorities.

#### 1.3 Documentation for Approval

##### 1.3.1 (1/1/2020)

The documentation for the monitoring strategy is to be in accordance with the requirements of Sec 1, [6.3]; in particular, the scope of the application is to be clearly illustrated. The CBM criteria to follow are laid out in Sec 1, [6.4] and Sec 1, [6.5]. Equipment not included therein will be the subject of special consideration.

#### 1.4 Implementation of the CBM

##### 1.4.1 (1/7/2009)

When the documentation submitted has been approved and the CBM has been implemented on board and used for a sufficient period (which is not to exceed one year) to allow the personnel to become familiar with it, a survey is to be carried out, in order to make the system officially operational, by a Surveyor of the Society or by another certified society.

##### 1.4.2 (1/7/2009)

Upon the successful outcome of this survey, the CBM is considered approved.

#### 1.5 Surveys

##### 1.5.1 (1/7/2009)

The same requirements laid out in Sec 1, [5] and Sec 1, [6] are valid, as applicable.

## SECTION 7

# CONDITION BASED MAINTENANCE OF MACHINERY ITEMS (PMS-CM)

### 1 General

#### 1.1 Application

##### 1.1.1 (1/1/2020)

The additional class notation **PMS-CM** is assigned to ships classed by the Society, eligible for the PMS additional class notation as per Sec 1 and complying with the requirements of this Section.

In the event that the ship undergoes modifications, refitting or repairs that may affect the items previously kept subject to Condition Based Maintenance (CBM), the retention of the notation is subject to the results of new measurements as deemed appropriate by the Society.

#### 1.2 Scope and requirements of PMS-CM Notation

##### 1.2.1 (1/1/2020)

The notation is assigned if CBM is applied to individual items selected by the Owner.

#### 1.3 Documentation for Approval

##### 1.3.1 (1/1/2020)

The documentation for the monitoring strategy is to be in accordance with the requirements of Sec 1, [6.3]; in par-

ticular, the scope of the application is to be clearly illustrated. The CBM criteria to follow for each piece of machinery are laid out in Sec 1, [6.4] and Sec 1, [6.5]. Equipment not included therein will be the subject of special consideration.

#### 1.4 Implementation of the CBM

##### 1.4.1 (1/1/2020)

When the documentation submitted has been approved and the CBM has been implemented on board and used for a sufficient period (which is not to exceed one year) to allow the personnel to become familiar with it, a survey is to be carried out, in order to make the system officially operational, by a Surveyor of the Society or by another certified society.

##### 1.4.2 (1/1/2020)

Upon the successful outcome of this survey, the CBM is considered approved.

#### 1.5 Surveys

##### 1.5.1 (1/1/2020)

The same requirements laid out in Sec 1, [5] and Sec 1, [6] are valid, as applicable.



## OTHER ADDITIONAL CLASS NOTATIONS

---

<b>SECTION 1</b>	<b>STRENGTHENED BOTTOM (STRENGTHBOTTOM-NAABSA)</b>
<b>SECTION 2</b>	<b>GRAB LOADING (GRABLOADING AND GRAB [X] )</b>
<b>SECTION 3</b>	<b>IN-WATER SURVEY ARRANGEMENTS (INWATERSURVEY)</b>
<b>SECTION 4</b>	<b>SINGLE POINT MOORING (SPM)</b>
<b>SECTION 5</b>	<b>CONTAINER LASHING EQUIPMENT (LASHING)</b>
<b>SECTION 6</b>	<b>DYNAMIC POSITIONING (DYNAPOS)</b>
<b>SECTION 7</b>	<b>VAPOUR CONTROL SYSTEM (VCS)</b>
<b>SECTION 8</b>	<b>COFFERDAM VENTILATION (COVENT)</b>
<b>SECTION 9</b>	<b>CENTRALISED CARGO AND BALLAST WATER HANDLING INSTALLATIONS (CARGOCONTROL)</b>
<b>SECTION 10</b>	<b>SHIP MANOEUVRABILITY (MANOVR)</b>
<b>SECTION 11</b>	<b>DAMAGE STABILITY (DMS)</b>
<b>SECTION 12</b>	<b>PROTECTIVE COATINGS IN WATER BALLAST TANKS (COAT-WBT)</b>
<b>SECTION 13</b>	<b>CREW ACCOMMODATION AND RECREATIONAL FACILITIES ACCORDING TO THE MARINE LABOUR CONVENTION, 2006 (MLCDESIGN)</b>
<b>SECTION 14</b>	<b>DIVING SUPPORT SHIPS (DIVINGSUPPORT)</b>
<b>SECTION 15</b>	<b>HIGH VOLTAGE SHORE CONNECTION (HVSC-NB AND HVSC)</b>
<b>SECTION 16</b>	<b>HELICOPTER FACILITIES (HELIDECK)</b>
<b>SECTION 17</b>	<b>FIRE PROTECTION (FIRE)</b>
<b>SECTION 18</b>	<b>CARRIAGE OF SPECIFIC SOLID CARGOES IN BULK</b>
<b>SECTION 19</b>	<b>SHIP EFFICIENCY - EFFICIENT SHIP (S, DWT)</b>
<b>SECTION 20</b>	<b>NAVIGATION SURROUNDING THE ARABIAN PENINSULA (SAHARA)</b>
<b>SECTION 21</b>	<b>MOORING (ANCHORING)</b>
<b>SECTION 22</b>	<b>INDOOR AIR QUALITY MONITORING (AIR MON)</b>
<b>SECTION 23</b>	<b>DEDICATED OIL RECOVERY SYSTEM (DORS)</b>
<b>SECTION 24</b>	<b>LNG READY (X1, X2, X3...) AND CNG READY (X1, X2, X3...)</b>
<b>SECTION 25</b>	<b>DOLPHIN QUIET SHIP AND DOLPHIN TRANSIT SHIP</b>
<b>SECTION 26</b>	<b>EXHAUST GAS CLEANING SYSTEMS (EGCS-SOX AND EGCS-NOX)</b>
<b>SECTION 27</b>	<b>MAN OVERBOARD DETECTION SYSTEM (MOB)</b>

<b>SECTION 28</b>	<b>HYBRID PROPULSION SHIP (HYB-...)</b>
<b>SECTION 29</b>	<b>CYBER RESILIENCE</b>
<b>SECTION 30</b>	<b>DIGITAL SHIP (ADC)</b>
<b>SECTION 31</b>	<b>AIR LUBRICATION SYSTEM (AIR LUB)</b>
<b>SECTION 32</b>	<b>PERSONS WITH REDUCED MOBILITY (PMR-ITA)</b>
<b>SECTION 33</b>	<b>BIOSAFE SHIP</b>
<b>SECTION 34</b>	<b>REMOTE</b>
<b>SECTION 35</b>	<b>NH3 FUELLED READY (X1, X2, X3...)</b>
<b>SECTION 36</b>	<b>SUSTAINABLE SHIP</b>
<b>SECTION 37</b>	<b>MARITIME AUTONOMOUS SURFACE SHIPS (MASS)</b>
<b>SECTION 38</b>	<b>H2 FUELLED READY (X1, X2, X3...)</b>
<b>SECTION 39</b>	<b>METHYL/ETHYL ALCOHOL FUELLED READY (X1, X2, X3...)</b>
<b>SECTION 40</b>	<b>ENHANCED MAINTENANCE (EM)</b>
<b>SECTION 41</b>	<b>CARGO PIPING PROTECTED (CPP)</b>
<b>SECTION 42</b>	<b>COATING PERFORMANCE STANDARD IN CARGO OIL TANKS (CPS-COT)</b>
<b>SECTION 43</b>	<b>DIGITAL SHIP (D)</b>
<b>SECTION 44</b>	<b>FUEL SAMPLING</b>
<b>SECTION 45</b>	<b>WIND ASSISTED PROPULSION SYSTEM (WAPS)</b>
<b>SECTION 46</b>	<b>ULTRA LOW EMISSION VESSEL (ULEV)</b>
<b>APPENDIX 1</b>	<b>TEST PROCEDURES FOR COATING QUALIFICATION FOR WATER BALLAST TANKS OF ALL TYPES OF SHIPS AND DOUBLE-SIDE SKIN SPACES OF BULK CARRIERS</b>
<b>APPENDIX 2</b>	<b>MOORING LOADS</b>
<b>APPENDIX 3</b>	<b>ADDITIONAL SYSTEMS, COMPONENTS AND OPERATIVE PROCEDURES TO EVALUATE THE BIOSAFE INDEX AS PER THE BIOSAFE NOTATION</b>
<b>APPENDIX 4</b>	<b>TEST PROCEDURES FOR COATING QUALIFICATION FOR CARGO OIL TANKS OF CRUDE OIL TANKERS</b>

**SECTION 1****STRENGTHENED  
(STRENGTHBOTTOM-NAABSA)****BOTTOM****1 General****1.1 Application****1.1.1 (1/1/2021)**

The additional class notation **STRENGTHBOTTOM-NAABSA** is assigned, in accordance with Pt A, Ch 1, Sec 2,[6.14.1], to ships built with specially strengthened bottom structures so as to be able to be loaded and/or unloaded, subject to specific loads when properly stranded and com-plying with the requirements of this Section.

**1.1.2 (15/10/2019)**

The assignment of additional class notation **STRENGTH-BOTTOM-NAABSA** assumes that the ship will only be grounded on plane, soft and homogeneous sea beds with no rocks or hard points and in areas where the sea is calm such as harbours or sheltered bays.

**1.1.3 Shell bottom (1/1/2021)**

Equipment installed in shell bottom, such as speed log or echo sounder, shall not protrude below the shell bottom plate.

**1.1.4 Rudder, propeller and appendages (1/1/2021)**

The rudder, propeller and appendages shall have a sufficient clearance to base line.

**1.1.5 Bow thruster (1/1/2021)**

If the vessel is equipped with a bow thruster, it shall be designed for NAABSA operation.

**2 Double bottom****2.1 Ships with L < 90 m and longitudinally framed double bottom****2.1.1 Plating (1/1/2021)**

The net thickness of the bottom and bilge platings, obtained from the formulae in Pt B, Ch 7, Sec 1 or Pt B, Ch 8, Sec 3, as applicable, is to be increased by 20%, and, in no case is to be less than 8 mm.

**2.1.2 Ordinary stiffeners (1/1/2021)**

The net scantlings of bottom and bilge ordinary stiffeners are to be in accordance with Pt B, Ch 7, Sec 2 or Pt B, Ch 8, Sec 4, as applicable.

The bottom and bilge ordinary stiffeners net scantlings are in addition to be in accordance to checks carried out with the following assumptions:

- a) the hull girder stress is to be taken equal to 0
- b) still water and wave pressures are to be taken as defined in Pt B, Ch 5, Sec 5 for upright ship conditions (load case "a") with positive  $h_1$
- c) the still water and wave pressures are to be considered as acting alone without any counteraction from ship internal pressure
- d) the permissible stress is taken as  $0,65 R_y$  (in lieu of  $R_y$ ) where  $R_y$  is the minimum yield stress, in  $N/mm^2$ , of the material, to be taken equal to  $235/k N/mm^2$  (the material factor  $k$  is defined in Pt B, Ch 4, Sec 1, [2.3])
- e) the partial safety factor for resistance  $\gamma_R$  is taken equal to 1,25
- f) the span  $\ell$  is to be taken not less than 1,5 m.

**2.1.3 Primary supporting members**

Solid floors are to be spaced not more than the lesser of the values  $0,025 L$  and 1,9 m.

A side girder is to be fitted on each side of the ship, in addition to those obtained by applying the requirements in Pt B, Ch 4, Sec 4, [4.1] for maximum spacing.

The number and size of holes on floors and girders are to be kept as small as possible, but are to be such as to allow complete inspection of double bottom structures.

**2.2 Ships with L < 90 m and transversely framed double bottom****2.2.1 Plating (1/1/2021)**

The net thickness of the bottom and bilge platings, obtained from the formulae in Pt B, Ch 7, Sec 1 or Pt B, Ch 8, Sec 3, as applicable, is to be increased by 20%. In any case, the net thickness is to be larger than 8 mm.

**2.2.2 Ordinary stiffeners**

Intercostal ordinary stiffeners are to be fitted for the whole flat bottom area when the actual spacing between girders is equal to or greater than two thirds of the maximum spacing specified in Pt B, Ch 4, Sec 4, [5.3]. Their scantlings are to be considered by the Society on a case by case basis.

**2.2.3 Primary supporting members**

Solid floors are to be fitted at every frame and are to be reinforced with vertical stiffeners spaced not more than 1,2 m.

A side girder is to be fitted on each side of the ship, in addition to those obtained by applying the requirements in Pt B, Ch 4, Sec 4, [5.3] for maximum spacing.

The number and size of holes on floors and girders are to be kept as small as possible, but are to be such as to allow complete inspection of double bottom structures.

### 2.3 Ships with $L \geq 90$ m and ships with $L < 90$ m subject to specific loads when properly stranded

#### 2.3.1 Plating, ordinary stiffeners and primary supporting members (1/1/2021)

The net scantlings of plating, ordinary stiffeners and primary supporting members are to be considered by the Society on a case by case basis, taking into account the specific hull girder and local loads induced by loading and unloading when stranded.

In any case the pressure  $p$  in  $\text{kN/m}^2$  acting on bottom in contact with the ground is to be considered not less than the value of the following formula and the checking criteria are to be in accordance to Pt B, Ch 7, Sec 1, Sec 2 and Sec 3 or Pt B, Ch 8, Sec 3, Sec 4 and Sec 5 as applicable.

$$p = 1,2g (\Delta/A - \rho T)$$

where:

- $\Delta$  : maximum displacement in tons of the ship in the specific load conditions considered.
- $T$  : minimum draft in m when the ship is stranded, in case the ship is completely in dry conditions  $T = 0$ .
- $A$  : area in  $\text{m}^2$  of the bottom in contact with the ground when the ship is stranded.
- $\rho$  : density of sea water.

## 3 Single bottom

### 3.1 Scantlings

#### 3.1.1 Plating, ordinary stiffeners and primary supporting members (1/1/2021)

The net scantlings of plating, ordinary stiffeners and primary supporting members are to be considered by the Society on a case by case basis, taking into account the specific hull girder and local loads induced by loading and unloading when stranded.



# SECTION 2 GRAB LOADING (GRABLOADING AND GRAB [X])

## 1 General

### 1.1 Application

#### 1.1.1 (1/4/2006)

In accordance with Pt A, Ch 1, Sec 2, [6.14.2], the following additional class notations are assigned:

- **GRABLOADING** to ships with holds specially reinforced for loading/unloading cargoes by means of buckets or grabs and complying with the requirements in [2]
- **GRAB [X]** to ships with holds designed for loading/unloading cargoes by grabs having a maximum mass of [X] tonnes and complying with the requirements in [3].

## 2 Class notation GRABLOADING

### 2.1 Inner bottom plating

#### 2.1.1 The net thicknesses of:

- inner bottom plating, where no ceiling is fitted
- hopper tank sloped plate and transverse stools, if any, up to 1,5 m from the inner bottom
- bulkhead plating, if no stool is fitted, up to 1,5 m from the inner bottom

obtained from the formulae in Pt B, Ch 7, Sec 1 or Pt B, Ch 8, Sec 3, as applicable, are to be increased by 5 mm.

Above 1,5 m from the inner bottom, the net thicknesses of the above plating may be tapered to those obtained from the formulae in Pt B, Ch 7, Sec 1 or Pt B, Ch 8, Sec 3, as applicable. The tapering is to be gradual.

## 3 Class notation GRAB [X]

### 3.1 Symbols

#### 3.1.1 (1/4/2006)

- $M_{GR}$  : mass of unladen grab, in t
- $s$  : spacing, in m, of ordinary stiffeners, measured at mid-span
- $k$  : material factor, defined in Pt B, Ch 4, Sec 1.

### 3.2 Plating

#### 3.2.1 (1/4/2006)

The net thickness of the inner bottom, lower strake of hopper tank sloping plate and transverse lower stool plating is to be taken as the greater of the following values:

- $t$ , as obtained according to the requirements in Pt B, Ch 7, Sec 1 or Pt B, Ch 8, Sec 3, as applicable;
- $t_{GR}$ , as defined in [3.2.2] and [3.2.3].

#### 3.2.2 (1/4/2006)

The net thickness  $t_{GR}$ , in mm, of the inner bottom plating is to be obtained from the following formula:

$$t_{GR} = 0,28(M_{GR} + 50)\sqrt{sk}$$

#### 3.2.3 (1/4/2006)

The net thickness  $t_{GR}$ , in mm, within the lower 3 m of the hopper tank sloping plate and of the transverse lower stool is to be obtained from the following formula:

$$t_{GR} = 0,28(M_{GR} + 42)\sqrt{sk}$$

## SECTION 3

# IN-WATER SURVEY ARRANGEMENTS (INWATERSURVEY)

### 1 General

#### 1.1 Application

**1.1.1** The additional class notation **INWATERSURVEY** is assigned, in accordance with Pt A, Ch 1, Sec 2, [6.14.3].

#### 1.2 Documentation to be submitted

##### 1.2.1 Plans

Detailed plans of the hull and hull attachments below the water line are to be submitted to the Society in triplicate for approval. These plans are to indicate the location and/or the general arrangement of:

- all shell openings
- stem
- rudder and fittings
- sternpost
- propeller, including the means used for identifying each blade
- anodes, including securing arrangements
- bilge keels
- welded seams and butts.

The plans are also to include the necessary instructions to facilitate the divers' work, especially for taking clearance measurements.

Moreover, a specific detailed plan showing the systems to be adopted in order to assess, when the ship is floating, the slack between pintles and gudgeons is to be submitted to the Society in triplicate for approval.

##### 1.2.2 Photographs (1/7/2010)

As far as practicable, a photographic documentation, used as a reference during the in-water surveys, of the following hull parts is to be submitted for information, in duplicate, to the Society:

- propeller boss
- rudder pintles, where slack is measured
- typical connections to the sea
- directional propellers, if any
- other details, as deemed necessary by the Society on a case by case basis.

##### 1.2.3 Documentation to be put on board

The Owner is to put on board of the ship the plans and documents given in [1.2.1] and [1.2.2], and they are to be made available to the Surveyor and the divers when an in-water survey is carried out.

### 2 Structure design principles

#### 2.1

##### 2.1.1 Marking

Identification marks and system are to be supplied to facilitate the in-water survey. In particular, the positions of transverse watertight bulkheads are to be marked on the hull.

##### 2.1.2 Rudder arrangements

Rudder arrangements are to be such that rudder pintle clearances and fastening arrangements can be checked.

##### 2.1.3 Tailshaft arrangements

Tailshaft arrangements are to be such that clearances (or wear down by poker gauge) can be checked.

## SECTION 4

## SINGLE POINT MOORING (SPM)

### 1 General

#### 1.1 Application

**1.1.1** The additional class notation **SPM** is assigned in accordance with Pt A, Ch 1, Sec 2, [6.14.4] to ships fitted forward with equipment for mooring at single point mooring or single buoy mooring terminals, using standardized equipment complying with the recommendations of the Oil Companies International Marine Forum (OCIMF), according to the requirements of this Section.

##### 1.1.2 (1/7/2008)

These requirements comply with and supplement the Recommendations for Equipment Employed in the Mooring of Ships at Single Point Moorings of the OCIMF (4th edition - 2007).

Note 1: Subject to Owner's agreement, applications for certification in compliance with the following previous editions of the OCIMF recommendations are examined by the Society on a case by case basis:

- 1st edition (1978): Standards for Equipment Employed in the Mooring of Ships at Single Point Moorings
- 2nd edition (1988): Recommendations for Equipment Employed in the Mooring of Ships at Single Point Moorings.

Note 2: The considered edition is specified in the Attestation relating to the SPM notation.

**1.1.3** Some components of the equipment used for mooring at single point moorings may be common with the bow emergency towing arrangements specified in Pt B, Ch 10, Sec 4, [4], provided that requirements of this section and of Pt B, Ch 10, Sec 4, [4] are complied with.

### 2 Documentation

#### 2.1 Documentation for approval

**2.1.1** In addition to the documents in Pt B, Ch 1, Sec 3, the following documentation is to be submitted to the Society for approval:

- general layout of the forecastle arrangements and associated equipment
- construction drawing of the bow chain stoppers, bow fairleads and pedestal roller fairleads, together with material specifications and relevant calculations
- drawings of the local ship structures supporting the loads applied to chain stoppers, fairleads, roller pedestals and winches or capstans.

#### 2.2 Documentation for information

**2.2.1** The following documentation is to be submitted to the Society for information (see Pt B, Ch 1, Sec 3):

- specifications of winches or capstans giving the continuous duty pull and brake holding force
- DWT, in t, of the ship at summer load line defined in Pt B, Ch 1, Sec 2, [3.8.1].

### 3 General arrangement

#### 3.1 General provision

**3.1.1** For mooring at SPM's terminals ships are to be provided forward with equipment to allow for heaving on board a standardized chafing chain of 76 mm in diameter by means of a pick-up rope and to allow the chafing chain to be secured to a strongpoint.

**3.1.2** The strongpoint is to be a chain cable stopper.

#### 3.2 Typical layout

**3.2.1** Fig 1 shows the forecastle schematic layout of the ship which may be used as reference.

#### 3.3 Equipment

**3.3.1** The components of the ship equipment required for mooring at single point moorings are the following:

- bow chain stopper, according to [5.1]
- bow fairlead, according to [5.2]
- pedestal roller fairlead, according to [5.3]
- winch or capstan, according to [5.4].

### 4 Number and safe working load of chain stoppers

#### 4.1 General

**4.1.1** The number of chain stoppers and their safe working load (SWL), in kN, depending on the DWT of the ship, are defined in Tab 1.

**4.1.2** Although required safe working load (SWL) is generally agreed by SPM's terminal operators, Owners and Shipyards are advised that increased safe working load may be requested by terminal operators to take account of local environmental conditions.

In such a case the Society is to be duly informed of the special safe working load to be considered.

Figure 1 : Forecastle schematic layout (1/7/2008)

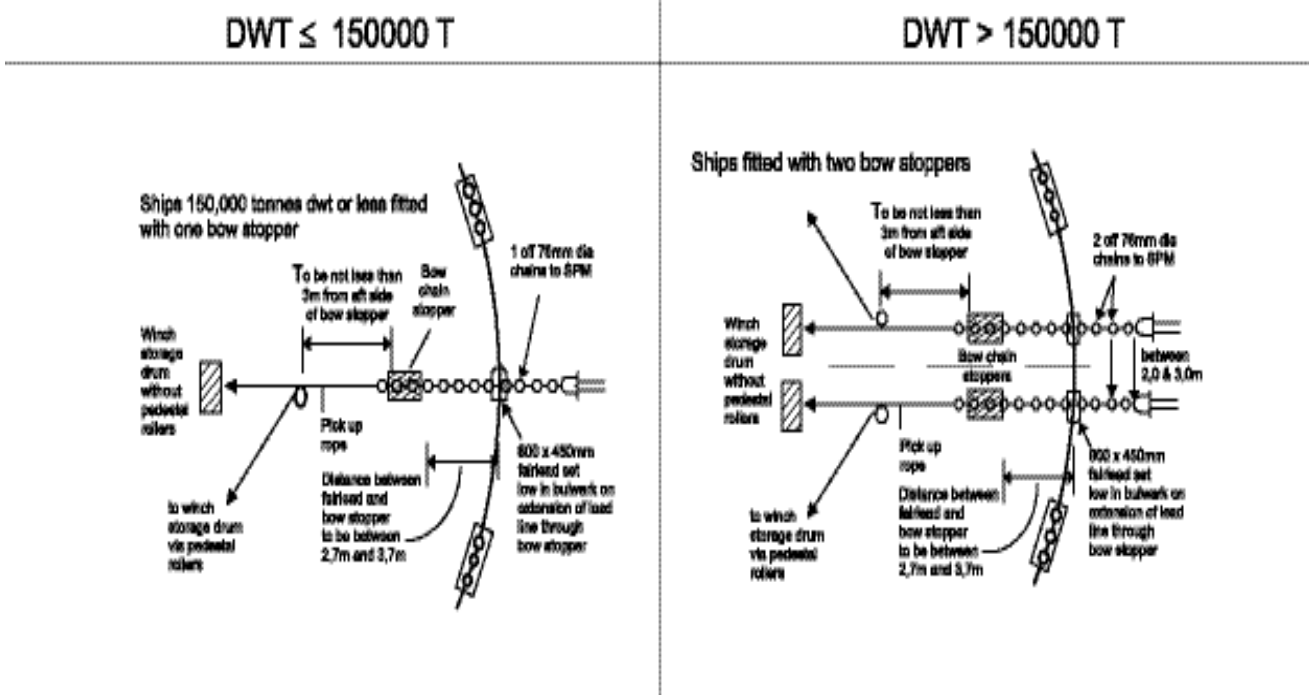


Table 1 : Number and SWL of chain stoppers

Deadweight, in t	Chain stoppers	
	Number	Safe working load (SWL), in kN
DWT ≤ 100000	1	2000
100000 < DWT ≤ 150000	2	2500
DWT > 150000	2	3500

## 5 Mooring components

### 5.1 Bow chain stopper

#### 5.1.1 (1/7/2008)

The ship is to be equipped with bow chain cable stoppers complying with the requirements in Tab 1 and designed to accept standard chafing chain of 76 mm in diameter.

5.1.2 The stoppers are to be capable to secure the 76 mm common stud links of the chain cable when the stopping device (chain engaging pawl or bar) is in the closed position and to freely pass the chain cable and its associated fittings when the stopping device is in the open position.

5.1.3 Chain stoppers may be of the hinged bar type or of pawl (tongue) type or of other equivalent design.

Typical arrangements of chain stoppers are shown in Fig 2.

5.1.4 The stopping device (chain engaging pawl or bar) of the chain stopper is to be arranged, when in the closed position, to prevent it from gradually working to the open

position, which would release the chafing chain and allow it to pay out.

Stopping devices are to be easy and safe to operate and, in the open position, are to be properly secured.

#### 5.1.5 (1/7/2008)

Chain stoppers are to be located between 2,7 m and 3,7 m inboard from the bow fairleads (see Fig 1).

When positioning, due consideration is to be given to the correct alignment of the stopper relative to the direct lead between bow fairlead and pedestal roller.

#### 5.1.6 (1/7/2008)

Bow chain stopper support structures are to be trimmed to compensate for any camber and/or sheer of the deck. The leading edge of the bow chain stopper base plate is to be faired to allow for the unimpeded entry of the chafing chain.

Bow chain stoppers are to be type approved according to the requirements in [5.5].

A copy of the manufacturer's type-approval certificate for the bow chain stopper(s) is to be kept on board.

The strength of the bow chain stopper foundations and associated ship supporting structure is to be checked with detailed stress analysis based on the actual local structure arrangement and considering the allowable stresses of Pt B, Ch 10, Sec 4, [3.1.15].

Bow chain stoppers are to be permanently marked with the SWL and appropriate serial numbers.

Bow chain stopper Manufacturers are to provide basic operating, maintenance and inspection instructions which are to be taken on board. Where appropriate, Manufacturers are also to provide guidance on maximum component wear limits.

**5.1.7** Where the chain stopper is bolted to a seating welded to the deck the bolts are to be relieved from shear force by efficient thrust chocks capable to withstand a horizontal force equal 1,3 times the required working strength and to meet, in this condition, the strength criteria specified in [7].

The steel quality of bolts is to be not less than grade 8.8 as defined by ISO standard No.898/1 (Grade 10.9 is recommended).

Bolts are to be pre-stressed in compliance with appropriate standards and their tightening is to be suitably checked.

**5.1.8** The chain stopper is to be made of fabricated steel (see Pt D, Ch 2, Sec 1) or other ductile materials such as steel forging or steel casting complying with the requirements of Pt D, Ch 2, Sec 3 or Pt D, Ch 2, Sec 4 respectively.

**5.1.9** Use of spheroidal graphite (SG) iron casting (see Pt D, Ch 2, Sec 5) may be accepted for the main framing of the chain stopper provided that:

- the part concerned is not intended to be a component part of a welded assembly
- the SG iron casting is of ferritic structure with an elongation not less than 12%
- the yield stress at 0,2% is to be measured and certified
- the internal structure of the component is to be inspected by means of non-destructive examinations.

**5.1.10 (1/7/2008)**

The material used for the stopping device (pawl or hinged bar) of chain stoppers is to have mechanical properties similar to grade R3 chain cable defined in Pt D, Ch 4, Sec 1 of the "Rules for the classification of floating offshore units at fixed locations and mobile offshore drilling units".

**5.2 Bow fairleads**

**5.2.1** One bow fairlead is to be fitted for each bow chain stopper (see Fig 1).

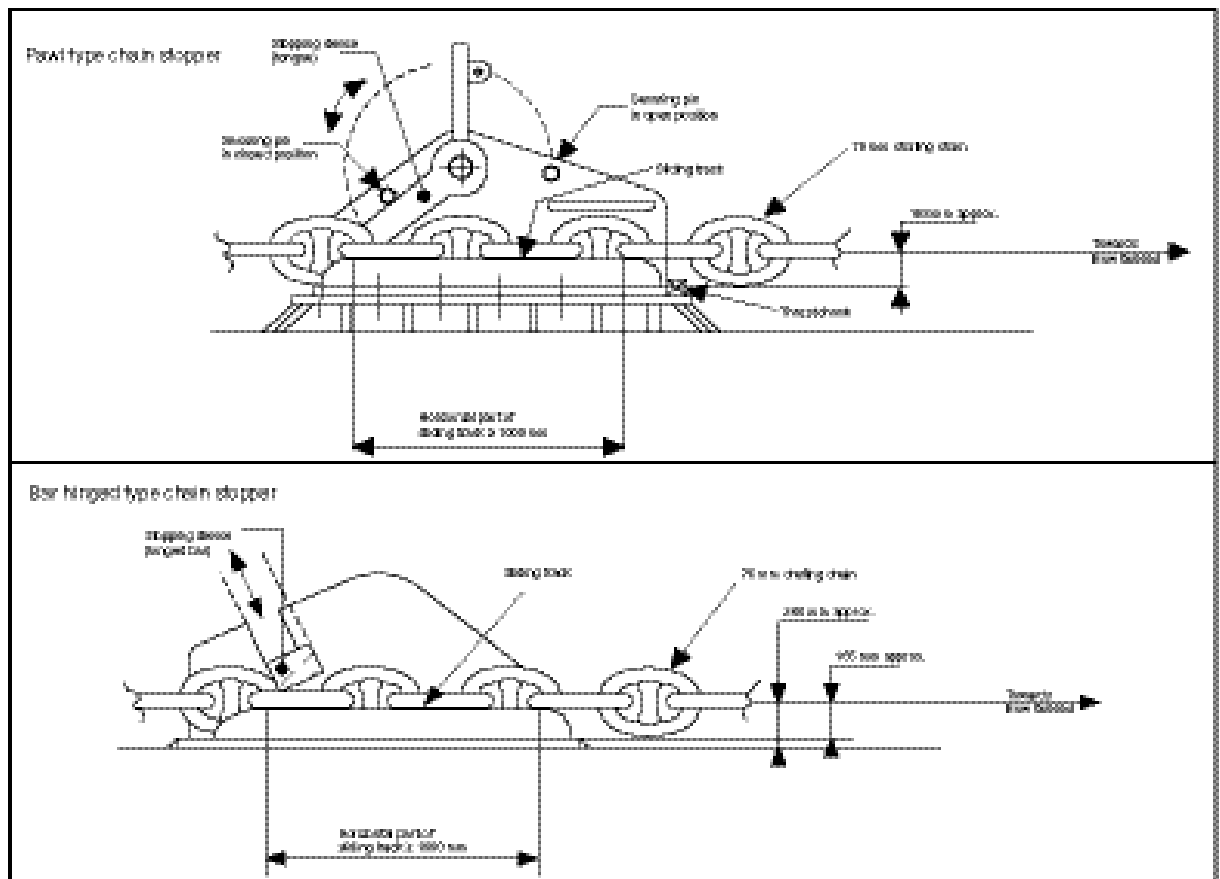
**5.2.2** For ships of more than 150000 t DWT, where two bow fairleads are required, the fairleads are to be spaced 2,0 m centre to centre apart, if practicable, and in no case be more than 3,0 m apart.

For ships of 150000 t DWT or less for which only one bow fairlead is required (see Tab 1), it is in general to be fitted on the centreline.

**5.2.3** Fairleads are normally of a closed type (as Panama chocks) and are to have an opening large enough to pass the largest portion of the chafing gear, pick-up rope and associated fittings.

For this purpose, the inner dimensions of the bow fairlead opening are to be at least 600 mm in width and 450 mm in height.

**Figure 2 : Typical bow chain stoppers**



**5.2.4** Fairleads are to be oval or round in shape.

The lips of the fairleads are to be suitably faired in order to prevent the chafing chain from fouling on the lower lip when heaving inboard.

The bending ratio (bearing surface diameter of the fairlead to chafing chain diameter) is to be not less than 7 to 1.

**5.2.5** The fairleads are to be located as close as possible to the deck and, in any case, in such a position that the chafing chain is approximately parallel to the deck when it is under strain between the chain stopper and the fairlead.

**5.2.6** Fairleads are to be made of fabricated steel plates (see Pt D, Ch 2, Sec 1) or other ductile materials such as weldable steel forging or steel casting complying with the requirements of Pt D, Ch 2, Sec 3 and Pt D, Ch 2, Sec 4 respectively.

**5.2.7** (1/7/2008)

The SWL of bow fairleads is to be not less than the SWL of the bow chain stoppers that they serve.

The safety factor on yield of bow fairleads is to be not less than 2,0.

The load position is to be based on hawser angles up to 90 degrees from the ship's centreline, both starboard and port in the horizontal plane and to 30 degrees above and below horizontal in the vertical plane.

Bow fairleads are to be type approved according to the requirements in [5.5].

A copy of the Type Approval Certificate for the bow fairleads is to be kept on board.

The strength of the bow fairleads hull connections and associated ship supporting structure is to be checked with detailed stress analysis based on the actual local structure arrangement and considering the allowable stresses of Pt B, Ch 10, Sec 4, [3.1.15].

Bow fairleads are to be permanently marked with the SWL and appropriate serial numbers.

**5.3 Pedestal roller fairleads**

**5.3.1** (1/7/2008)

It is recommended that winch storage drums used to recover the pick-up ropes are positioned in a direct straight lead with the bow fairlead and bow chain stopper without the use of pedestal rollers.

If pedestal rollers are used, the number of pedestal rollers for each bow chain stopper is not to exceed two and the angle of change of direction of the pick-up rope lead is to be kept minimal.

It is recommended that remote operated winch storage drums are used.

If pedestal rollers are used, the requirements from [5.3.2] to [5.3.4] are to be applied.

**5.3.2** Pedestal roller fairleads are to be positioned to enable a direct pull to be achieved on the continuation of the direct lead line between the bow fairlead and bow chain stopper (see Fig 1).

They are to be fitted not less than 4,5 m behind the bow chain stopper.

**5.3.3** The pedestal roller fairleads are to be capable to withstand a horizontal force equal to the greater of the two values:

- 225 kN
- the resultant force due to an assumed pull of 225 kN in the pick-up rope.

Stresses generated by this horizontal force are to comply with the strength criteria indicated in [7].

**5.3.4** It is advised that the fairlead roller is to have a diameter not less than 7 times the diameter of the pick-up rope. Where the diameter of the pick-up rope is unknown it is advised that the roller diameter be of 400 mm, at least.

**5.4 Winches or capstans**

**5.4.1** Winches or capstans used to handle the mooring gear are to be capable of heaving inboard a load of 15 t at least. For this purpose winches or capstans are to be capable to exert a continuous duty pull of not less than 150 kN and to withstand a braking pull of not less than 225 kN.

**5.4.2** (1/7/2008)

If a winch storage drum is used to stow the pick-up rope, it is to be of sufficient size to accommodate 150 m of rope of 80 mm diameter.

Use of winch drum ends (warping ends) to handle pick-up ropes is not allowed.

**5.5 Type approval**

**5.5.1 Procedure** (1/7/2008)

Bow chain stoppers and fairleads are to be type approved according to the following procedure:

- the design is to comply with the requirements of this Section
- the bow chain stopper and fairlead are to be tested and their manufacturing is to be witnessed and certified by a Surveyor according to Tab 2.

**5.5.2** (1/7/2008)

Inspection and certification testing is to be carried out according to Tab 2.

**Table 2 : Material and component certification status**

	Material		Component	
	Certificate	Reference of applicable requirements	Certificate	Reference of applicable requirements
Chain stoppers	COI (1)	[5.1.8]	COI (2)	Recognised standards (3)
Fairleads	CW	[5.2.6]	COI	[5.2]
<p>(1) according to Part D, Chapter 1.  (2) to be type approved.  (3) the recognised standard is to specify SWL, yield strength and safety factors</p> <p><b>Note 1:</b>  COI: certificate of inspection  CW: works' certificate 3.1.B according to EN 10204</p>				

## 6 Supporting hull structures

### 6.1 General

**6.1.1** The bulwark plating and stays are to be suitably reinforced in the region of the fairleads.

**6.1.2** Deck structures in way of bow chain stoppers, including deck seatings and deck connections, are to be suitably reinforced to resist to a horizontal load equal to 1,3 times the required working strength and to meet, in this condition, the strength criteria specified in [7].

As a guidance, the local deck thickness is to be, at least, equal to:

- 15 mm for working strength 2 000 kN
- 18 mm for working strength 2 500 kN.

For deck bolted chain stoppers, reinforcements are to comply with [5.1.7].

**6.1.3** The deck structures in way of the pedestal roller fairleads and in way of winches or capstans as well as the deck connections are to be reinforced to withstand, respectively, the horizontal force defined in [5.3.3] or the braking pull

defined in [5.4.1] and to meet the strength criteria specified in [7].

**6.1.4** Main welds of the bow chain stoppers with the hull structure are to be 100% inspected by means of non-destructive examinations.

## 7 Strength criteria

### 7.1 General

**7.1.1** The equivalent stress  $\sigma_{VM}$  induced by the loads in the equipment components (see [3.3]), is to be in compliance with the following formula:

$$\sigma_{VM} \leq \sigma_a$$

where:

- $\sigma_a$  : Permissible stress, to be taken, in N/mm<sup>2</sup>, as the minimum between 0,67  $R_{eH}$  and 0,4  $R_m$
- $R_{eH}$  : Minimum yield stress, in N/mm<sup>2</sup>, of the component material
- $R_m$  : Tensile strength, in N/mm<sup>2</sup>, of the component material.

## SECTION 5

## CONTAINER LASHING EQUIPMENT (LASHING)

### 1 General

#### 1.1 Application

##### 1.1.1 (1/7/2017)

The additional class notation **LASHING** or **ROUTE DEPENDENT LASHING (start date - end date)** is assigned, in accordance with Pt A, Ch 1, Sec 2, [6.14.5], to mobile lashing equipment and removable cell guides, for the period of year defined by the specification start date - end date, complying with the requirements of this Section.

##### 1.1.2 (1/7/2017)

The procedure for the assignment of the additional class notation **LASHING** includes:

- the approval of the lashing plans and mobile lashing equipment
- the type tests of the mobile lashing equipment and the issuance of Type Test Certificates to the relevant equipment
- the inspection at works during manufacture of the mobile lashing equipment and the issuance of Inspection Certificates to the relevant equipment
- the general survey on board of mobile lashing equipment and sample test of mounting of equipment
- the approval of the lashing computer software.

For the assignment of the notation **ROUTE DEPENDENT LASHING (start date - end date)** the lashing plans have also to include:

- specification of the intended routes with the indications of the relevant latitude and longitude coordinates for discrete route points
- example of route specific arrangement plans, for deck and hold stowage, at least in three locations of the ship cargo area.

#### 1.2 Documents to be kept on board

##### 1.2.1 (1/11/2013)

The following plans and documents are to be kept on board the ship:

- lashing plan, plan of arrangement of stowage and lashing equipment and documents relevant to the lashing calculation software approval
- testing documents relevant to the different mobile lashing devices and parts employed for securing and locking containers.

#### 1.3 Materials

##### 1.3.1 Steel wires and chains

Steel wires and chains materials are to comply with the applicable requirements of Part D.

##### 1.3.2 Lashing rods

Lashing rods are generally required to be of Grade A or AH hull steel, or steel having equivalent mechanical properties.

##### 1.3.3 Securing and locking devices

Securing and locking devices may be made of the following materials:

- Grade A or AH hull steel or equivalent
- cast or forged steel having characteristics complying with the requirements of Part D, with particular regard to weldability, where required.

##### 1.3.4 Plates and profiles

Plates and profiles for cells in holds or for frameworks on deck, or on hatch covers, are to comply with the applicable requirements of Part D.

##### 1.3.5 Other materials

The use of nodular cast iron or materials other than steel will be specially considered by the Society on a case by case basis.

### 2 Arrangements of containers

#### 2.1 General

**2.1.1** Containers are generally aligned in the fore and aft direction and are secured to each other and to the ship structures so as to prevent sliding or tipping under defined conditions. However, alternative arrangements may be considered.

**2.1.2** Containers are to be secured or shored in way of corner fittings. Uniform load line stowage is to be considered by the Society on a case by case basis.

**2.1.3** One or more of the following methods for securing containers may be accepted:

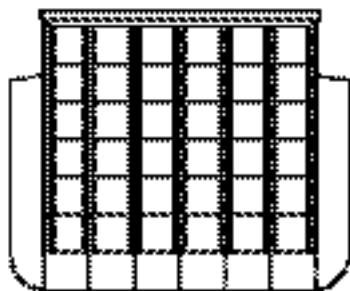
- corner locking devices
- steel wire ropes or chain lashing
- steel rods
- buttresses or shores permanently connected to the hull
- cell guides.

**2.1.4** In ships with the service notation **container ship**, containers in holds are generally stowed within cell guides (see Fig 1).

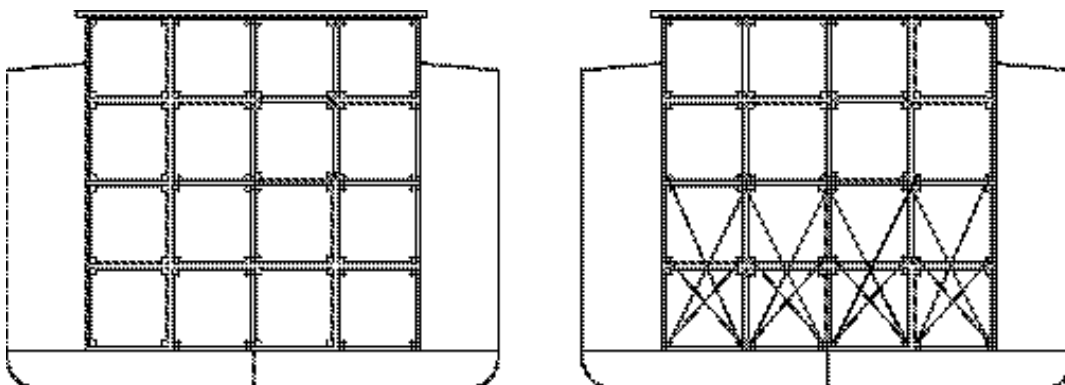
**2.1.5** In ships with the additional service feature **equipped for the carriage of containers**, containers in holds are generally mutually restrained to form blocks which are shored, transversely and longitudinally, by hull structures, or restrained by lashings or lashing rods (see Fig 2).



**Figure 1 : Containers in holds within removable cell guides**



**Figure 2 : Containers in holds arranged in blocks**



## 2.2 Stowage in holds using removable cell guides

**2.2.1** Cell guides of removable type are to form a system as independent as possible of hull structure. They are generally bolted to hull structures.

**2.2.2** Vertical guides generally consist of sections with equal sides, not less than 12 mm in thickness, extended for a height sufficient to give uniform support to containers.

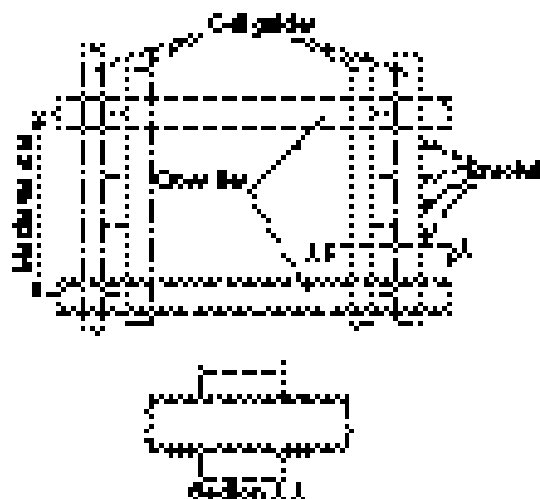
**2.2.3** Guides are to be connected to each other and to the supporting structures of the hull by means of cross ties and longitudinal members such as to prevent deformation or misalignment due to the action of forces transmitted by containers.

In general, the spacing between cross ties connecting the guides may not exceed 5 metres, and their position is to coincide as nearly as possible with that of the container corners (see Fig 3).

Cross ties are to be longitudinally restrained at one or more points so that their elastic deformation due to the action of the longitudinal thrust of containers does not exceed 20 mm at any point.

Such restraints may be constituted by longitudinal members, steel stay wire ropes or equivalent arrangements.

**Figure 3 : Typical structure of cell guides**



**2.2.4** In stowing containers within the guides, the clearance between container and guide is not to exceed 25 mm in the transverse direction and 38 mm in the longitudinal direction.

**2.2.5** The upper end of the guides is to be fitted with an appliance to facilitate entry of the containers. Such appliance is to be of robust construction with regard to impact and chafing.

**2.2.6** When it is intended to carry 20' containers within 40' cells, removable vertical guides forming a stop for the side ends of the 20' container block may be fitted at mid cell length.

When such removable vertical guides are not fitted, the following are to be complied with:

- 20' containers are to be of the closed box type
- at least one 40' container is to be stowed at the top of 20' containers stacks
- containers are to be secured by simple stacking cones at each tier
- the number of tiers of 20' containers and the weight of 20' containers are to be such that the loads applied to container frames are to satisfy the strength criteria in [6].

Equivalent arrangements may be accepted by the Society on a case by case basis.

### 2.3 Stowage under deck without cell guides

**2.3.1** Containers are stowed side by side in one or more tiers and are secured to each other at each corner at the base of the stack and at all intermediate levels.

**2.3.2** Securing arrangements may be either centring or stacking cones or, if calculations indicate that separation forces may occur, locking devices.

**2.3.3** Each container block is to be shored transversely, by means of buttresses acting in way of corners, supported by structural elements of sufficient strength, such as, for example, web frames or side stringers or decks.

**2.3.4** The number of buttresses is to be determined taking into account the maximum load that can be supported by corners and by the end frames of containers (see [6]).

The hull structures in way of buttresses of container blocks are to be adequately reinforced.

Side buttresses may be capable of withstanding both tension and compression loads and may be either fixed or removable. They are to be fitted with means to adjust tension or compression and their position is to be easily accessible to allow such adjustment.

**2.3.5** Each row of containers is to be connected to that adjacent by means of double stacking cones or equivalent arrangements and, if containers are subdivided into separate blocks, connection devices of sufficient strength to transmit the loads applied are to be fitted at shoring points.

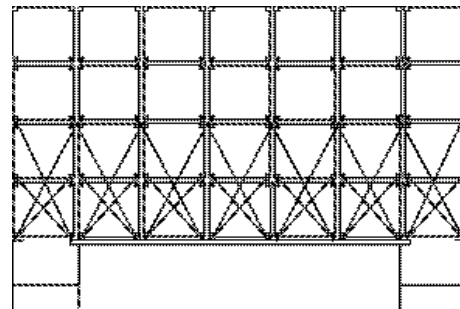
**2.3.6** If hull structural elements of sufficient strength to support buttresses are not available, as an alternative to the above, containers may be secured by means of lashings or lashing rods, similarly to the arrangements for containers stowed on deck or on hatch covers.

### 2.4 Stowage on exposed deck

**2.4.1** The arrangement and number of containers stowed on exposed deck (see Fig 4) may be accepted after assessment of the following elements:

- actual mass of containers
- exposure to sea and wind
- stresses induced in the lashing system, in the container structure and in hull structures or hatch covers
- ship's stability conditions.

**Figure 4 : Stowage of containers on exposed deck**



**2.4.2** Containers are generally arranged in several rows and tiers so as to constitute blocks. The arrangement of containers is to be such as to provide sufficient access to spaces on deck for operation and inspection of the lashing devices and for the normal operation of personnel.

**2.4.3** Containers are to be secured by locking devices fitted at their lower corners at each tier, and capable of preventing horizontal and vertical movements. Bridge fittings are to be used to connect the tops of the rows in the transverse direction

Alternatively, lashings fitted diagonally or vertically on containers corners may be used to prevent vertical movements in addition with centring and stacking cones fitted between the tiers and in way of the base of the stack to prevent horizontal movements.

The upper tier containers are to be secured to the under tier containers by means of locking devices fitted at their corners and located between the two tiers.

**2.4.4** Locking devices are to be used every time the calculations indicate that separation forces may occur.

Where the calculations indicate that separation forces will not occur, double stacking cones may be fitted instead of locking devices at all internal corners of the stack and bridge fittings are to be used to connect the tops of the rows in the transverse direction.

**2.4.5** The external containers are not to extend beyond the ship's side, by they may overhang beyond hatch covers or other ship structures, on condition that adequate support is provided for the overhanging part.

**2.4.6** Securing of containers stowed at ship's side are to be arranged taking account of the possibility of water ingress and consequent buoyancy depending on container volume. In small ships such buoyancy is to be taken equal to that corresponding to the total volume of the container concerned.

**2.4.7** The arrangement of containers forward of 0,75 L from the aft end is to be considered by the Society on a case by case basis.

The Society reserves the right to require a limitation in the number of tiers and the fitting of additional securing devices.

**2.4.8** The maximum stack height is to be such as to leave a sufficient sightline from the navigating bridge.

## **2.5 Uniform line load stowage on deck or hatch covers**

**2.5.1** Instead of resting on their four lower corners, containers may be arranged on deck or on hatch covers with their bases in uniform contact with the supporting structure. This can be done, for example, by fitting wood planks or continuous metal beams under the lower longitudinal sides (chocks are not allowed), or by inserting the lower corners into special recesses provided on deck or on hatch covers.

A clearance not less than 5 mm is to be left between corners and deck structure, or hatch cover structure underneath (according to ISO standards, the maximum protrusion of the corner fitting beyond the lower side longitudinal is 17,5 mm).

**2.5.2** Such arrangement is, in general, permitted only for a single container or containers in one tier.

For containers in more than one tier, such arrangement may only be accepted if the total mass of the containers above the first tier does not exceed 50% of the total maximum gross mass of containers of the same type and size complying with ISO standards.

**2.5.3** Containers are to be adequately secured to avoid transverse sliding and tipping.

## **3 Procedure for the assignment of the notation**

### **3.1 Approval of the mobile lashing equipment**

**3.1.1** Each type of mobile lashing equipment is to be approved by the Society on the basis of:

- the submitted documents (see Pt B, Ch 1, Sec 3, [2.3])
- the determination of loads
- the checking of the strength criteria
- the conditions of manufacturing
- the manufacturer's control during manufacturing
- the identification of the piece
- the results of the type tests.

## **3.2 Type tests**

**3.2.1** Type tests are to be carried out as indicated in the following procedure, or by a procedure considered as equivalent by the Society:

- a breaking test is to be carried out on two pieces for each type of mobile lashing equipment
- samples and dimensions of the tested pieces are to be identical to those given in the detailed drawing of the equipment
- load conditions of the test (i.e. tensile, shear, compression or tangential load) are to be as close as possible to the actual conditions of loading in operation.

Supplementary tests may be asked for by the Society on a case by case basis, depending on the actual conditions of operation.

Test to be carried out on the most common types of securing and lashing elements are indicated in Tab 1 to Tab 3.

**3.2.2** When a lashing element consists of several components, the test is to be carried out on the complete element.

**3.2.3** The breaking load corresponds to the load reached at the moment where the first cracks appear on the test piece.

**3.2.4** The breaking load obtained from tests is to be at least equal to the breaking load foreseen by the manufacturer and indicated on the detailed drawing.

When one of the breaking loads obtained from tests on the two pieces is lower than the value foreseen by the manufacturer by a value not exceeding 5 %, a third piece is to be tested. In such a case, the mean breaking load over the three tests is to be not lower the theoretical value foreseen by the manufacturer.

**3.2.5** The breaking test may be stopped when the piece does not break for an applied load exceeding the breaking load declared by the manufacturer.

**3.2.6** The breaking load is to be equal at least to 2 times the safe working load (SWL) indicated by the manufacturer.

**3.2.7** A Test Report is to be issued with the following information:

- identification of the manufacturer and of the manufacturing factory
- piece type and quantity of tested pieces
- identification number of the piece
- materials, with mechanical characteristics
- measured breaking loads and comments on the tests, if any
- Safe Working Load.

**3.2.8** When the tests are considered as satisfactory, a Type Test Certificate is issued by the Society.

The following information are to be indicated in the Type Test Certificate:

- identification of the manufacturer and of the manufacturing factory
- piece type
- identification number of the piece
- breaking load and Safe Working Load
- reference of the Test Report (see [3.2.7]), which is to be attached to the Type Test Certificate.

**3.2.9** Each sample is to be clearly identified in the documents kept on board, as required in [1.2.1].

**3.3 Inspection at works of the mobile lashing equipment**

**3.3.1** Lashing equipment are to be tested and inspected at production works with the attendance of a Surveyor from the Society.

**3.3.2** Tests are to be carried out under load conditions (i.e. tensile, shear, compression or tangential load) as close as possible to the actual conditions of loading in operation.

Test to be carried out on the most common types of securing and lashing elements are indicated in Tab 1 to Tab 3.

**3.3.3** It is to be checked that a valid Type Test Certificate is granted to the inspected pieces, and that the pieces specifications are identical to the ones described in the Type Test Certificate.

**3.3.4** Equipment is to be batch-surveyed. The batch includes a maximum of 50 pieces.

Two pieces by batch (three in case of wire ropes with their ends) are to be tested under a load equal to 1,3 times the Safe Working Load. If mass production does not exceed 50 pieces, the test is to be carried out on at least one piece.





When a lashing element consists of several components, the test is to be carried out on the complete element.

The tested pieces are not to show cracks or permanent deformation.


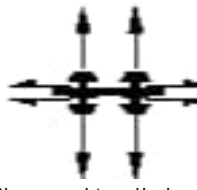




**3.3.5** At least, 10% of the pieces are to be examined visually.

It is also checked that the identification number and the Safe Working Load (SWL) declared by the manufacturer are indicated on the examined pieces.

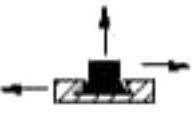



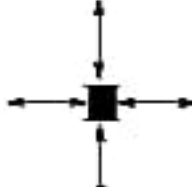
**Table 1 : Test modes for lashing pieces**

Test modes for lashing pieces	
<p>Lashing rod, chain and steel wire rope</p>  <p>Tensile load</p>	<p>Penguin hook</p>  <p>Tangential load</p>
<p>Turnbuckle</p>  <p>Tensile load</p>	<p>Hook</p>  <p>Tensile load</p>

**Table 2 : Test modes for connecting pieces between containers**

Test modes of connecting pieces between containers		
<p>Twistlock</p>  <p>Shear and tensile loads</p>	<p>Double twistlock</p>  <p>Shear and tensile loads</p>	<p>Bridge fitting</p>  <p>Tensile load</p>
<p>Single stacker</p>  <p>Shear load</p>	<p>Double stacker</p>  <p>Shear and tensile loads</p>	<p>Buttress</p>  <p>Tensile load</p>

**Table 3 : Test modes for mobile securing pieces**

Test modes for mobile securing pieces		
<p>Bottom twistlock</p>  <p>Shear and tensile load</p>	<p>Stacking cone</p>  <p>Shear load</p>	<p>Stacking cone with pin</p>  <p>Shear and tensile load</p>
<p>Pillar on deck</p>  <p>Compression load</p>	<p>Intermediate pillar</p>  <p>Shear, compression and tensile load</p>	

**3.3.6** The Surveyor from the Society may require tests to be repeated or carried out on a greater number of samples, if considered as necessary.

**3.3.7** If the test proves satisfactory and after examination of documents describing the batch, an Inspection Certificate is issued and the equipment is identified by the manufacturer and each piece is stamped by the Surveyor. The reference of the Type Test Certificate and the quantity of tested pieces are indicated on the Inspection Certificate.

### **3.4 Reception of board of the mobile lashing equipment**

**3.4.1** The mobile lashing equipment on board is to have an Inspection Certificate (see [3.3]).

Tests of mounting of mobile lashing equipment in accordance with the operation conditions and the lashing plan arrangement are to be carried out.

### 3.5 Approval of lashing software

#### 3.5.1 Definition (1/7/2023)

Lashing software is an electronic data processing tool for on-board analysis of forces in container stacks and thereby reflects the parameters of the lashing system as described in the Cargo Securing Manual.

An approved lashing software is not a substitute for the approved Cargo Securing Manual. It is considered as a supplement to the approved Cargo Securing Manual.

The lashing software is a ship specific tool, and the results of the calculations are only applicable to the ship for which it has been approved.

#### 3.5.2 Lashing calculation software (1/7/2023)

To calculate and verify the container lashing arrangement, a lashing software approved by the Society is required on board.

For the assignment of the notation **ROUTE DEPENDENT LASHING**, the specific Route Dependent Factor  $F_R$ , refer to [4.4] is to be taken into account by the lashing calculation.

#### 3.5.3 Operation Manual (1/7/2023)

An operation manual in electronic copy is to be provided for the lashing software and be kept on board.

The language in which the lashing software results are displayed and printed out and in which the operation manual is written is to be the same as used in the approved Cargo Securing Manual. A translation into another language considered appropriate may be required.

The operation manual is to contain descriptions and instructions, as appropriate, for at least the following:

- a general description of the lashing software;
- installation;
- function keys;
- menu displays;
- input and output data;
- required minimum hardware to operate the software;
- instruction on testing the lashing software with the test loading condition;
- a list of all terms, definitions, error messages and warnings likely to be encountered by the user; and
- in the case of error messages and warnings, there are to be unambiguous user instructions for subsequent action to be taken in each case.

#### 3.5.4 Functional Requirements (1/7/2023)

The lashing software is to be capable of calculating forces on containers and container securing equipment for any loading conditions for each container stack.

It is also to be capable of indicating the respective permissible values in order to assist the master in his/her judgement on whether the ship is loaded within the approved limits. The following parameters are to be presented:

- summary of ship particulars such as IMO No., length, and breadth;
- summary of loading conditions showing relevant input parameters such as draught and GM;

- stack and container positions;
- actual stack weights verified against permissible ship's structural loads;
- relevant details of securing and lashing devices;
- accelerations and other external forces such as wind and/or green seas containers are exposed to;
- listing of all calculated container and container securing equipment forces and evaluation of compliance of the calculated forces with the corresponding allowable values.

The container and lashing arrangements in each bay on deck and in holds are to be shown graphically and the results are to be presented in an unambiguous manner such as tabularly.

A clear warning is to be given on screen and in hard copy printout if any of the allowable forces are exceeded.

The data are to be presented on screen and in hard copy printout in a clear and unambiguous manner.

In addition to the printout content, each page of the printout is to contain ship's identification, lashing software name and version number, date and time of the printout, and the title of the loading condition. The printout is to be paginated sequentially, and the total number of printout pages are to be shown.

Units of measurement are to be clearly identified and used consistently.

Incorrect data input by the users, such as negative draught values, are to be prohibited. An error message is to be prompted on screen and in hard copy printout in a clear and unambiguous manner.

#### 3.5.5 Test loading conditions (1/7/2023)

The lashing software is to be delivered with test loading conditions for different bays covering applicable stowage patterns for containers of different dimensions contained in the Cargo Securing Manual.

The test loading conditions and their results are to be permanently stored in the computer where the lashing software is installed and be protected against unintentional or unauthorized modifications and access.

#### 3.5.6 Approval of lashing software (1/7/2023)

The approval of lashing software is to include:

- verification of type approval, if any;
- verification that the latest ship data has been used;
- verification and approval of the test loading conditions;
- verification if requirements in [3.5.4] are satisfied;
- checking of proper installation and operation of the instrument on board in accordance with the approved test loading conditions;
- checking the availability of the operation manual on board.

In case of modifications implying changes in the ship's design or container securing arrangement, the software is to be modified accordingly and re-approved.

Any changes in software version related to the container securing calculations are to be reported to and be approved by the Society.

The operation of the lashing software is to be verified upon installation in the presence of Society surveyor. It is to be checked that the approved test loading conditions and the operation manual for the lashing software are available on board.

Verification by the Society does not absolve the shipowner of responsibility for ensuring that the information supplied into the lashing software is consistent with the current condition of the ship and approved Cargo Securing Manual.

### 3.5.7 Acceptable Tolerances (1/7/2023)

The accuracy of the lashing software is to be within the acceptable tolerance of  $\pm 5\%$  of the results obtained by the Society, using independent calculations according to Rules or the approved Cargo Securing Manual with identical inputs.

Deviations from the above tolerances may be accepted by the Society provided that there is a satisfactory explanation for the deviation and that there will be no adverse effects on the safety of the ship.

### 3.5.8 Periodical Survey (1/7/2023)

At each periodical survey, it is to be checked that the operation manual is available on board.

The lashing software is to be checked for accuracy annually by the ship's Master by applying the test loading conditions. If Society surveyor is not present for lashing software check, a copy of the test loading condition results obtained by this check is to be retained on board as documentation of satisfactory testing for the surveyor's verification at the next scheduled survey.

### 3.5.9 Other Requirements (1/7/2023)

The lashing software and its data are to be protected against unintentional or unauthorized modifications and access.

The hardware, on which the lashing software is installed, is to be in compliance with IACS Recommendation No. 48.

## 4 Forces applied to containers

### 4.1 General

**4.1.1** The devices constituting the lashing system are to be capable of withstanding the specified loading condition declared for the ship.

**4.1.2** The loads to be considered in lashing system calculations are the following:

- still water and inertial forces (see [4.3])
- wind loads (see [4.5])
- forces imposed by lashing and securing arrangements (see [4.6])
- sea pressure (see [4.7]).

## 4.2 Definitions

### 4.2.1 Stack of containers

A stack of container consists of "N" containers connected vertically by securing devices.

The container located at the level "i" within a stack is indicated on Fig 5.

### 4.2.2 Block of containers

A block of containers consists of "M" stacks connected transversely by corner fittings.

## 4.3 Still water and inertial forces

**4.3.1** The still water and inertial forces applied to one container located at the level "i", as defined in [4.2.1], are to be determined on the basis of the forces obtained, in kN, as specified in Tab 4.

### 4.3.2 (1/7/2015)

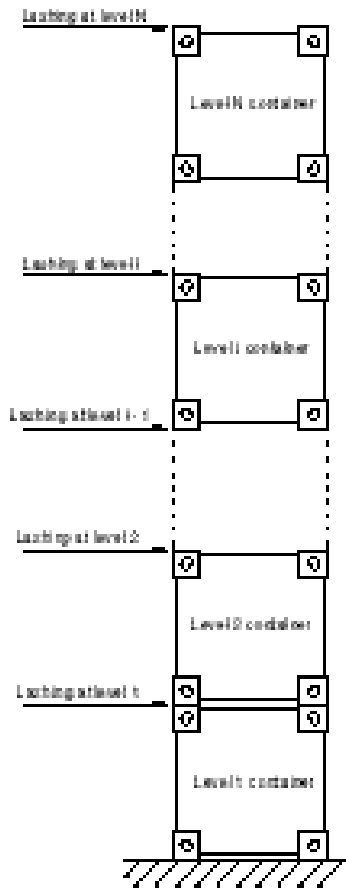
The distance of the centre of gravity of a container may be obtained, in m, from the following formula:

$$z_i = z_L + d_{CGi}$$

where:

- $z_L$  : Z co-ordinate, in m, at the stack bottom, with respect to the reference co-ordinate system defined in Pt B, Ch 1, Sec 2, [4]
- $d_{CGi}$  : Distance, in m, between the stack bottom and the centre of gravity of the container at the level "i", to be taken not greater than  $0,305H_0(N_{i-1} + \alpha)$
- $\alpha$  : Coefficient to be taken equal to:
- $\alpha = 0,5$  for a stack in hold
  - $\alpha = 0,45$  for a stack on deck
- $N_{i-1}$  : Number of containers stowed in the stack under the container at the level "i"
- $H_0$  : Height of a container, in feet, all the containers of the stack being considered of the same height.

Figure 5 : Containers level in a stack



4.3.3 Where empty containers are stowed at the top of a stack, the still water and inertial forces are to be calculated considering mass of empty container equal to:

- 0,14 times the mass of a loaded container, in case of steel containers
- 0,08 times the mass of a loaded container, in case of steel aluminium containers.

Table 4 : Container at level "i"  
Still water and inertial forces (1/7/2015)

Ship condition	Still water force $F_S$ and inertial force $F_W$ , in kN
Still water condition	$F_{S,i} = M_i g$
Upright condition	$F_{W,x,i} = M_i F_R a_{x1}$ in x direction $F_{W,z,i} = M_i F_R a_{z1}$ in z direction
Inclined condition (negative roll angle)	$F_{W,y,i} = M_i F_R F_C a_{y2}$ in y direction $F_{W,z,i} = M_i F_R F_C a_{z2}$ in z direction
<b>Note 1:</b>	
$g$	: gravity acceleration, in $m/s^2$ : $g = 9,81 m/s^2$
$M_i$	: mass, in t, of the container considered at the level "i" (see also [4.3.3]),
$F_R$	: Route Dependent Factor, to be taken: <ul style="list-style-type: none"> <li>• equal to 1, for the assignment of the notation <b>LASHING</b></li> <li>• as defined in [4.4], for the assignment of the notation <b>ROUTE DEPENDENT LASHING</b></li> </ul>
$F_C$	: 1,10 for $GM = 0 m$ ; 1,35 for $GM = 0,07xB$ ; values for intermediate GMs to be obtained from linear interpolation,
$a_{x1}, a_{z1}$	: accelerations, in $m/s^2$ , for the upright ship condition, determined according to Pt B, Ch 5, Sec 3, [3.4] at the centre of gravity of the container (see [4.3.2]),
$a_{y2}, a_{z2}$	: accelerations, in $m/s^2$ , for the inclined ship condition, determined according to Pt B, Ch 5, Sec 3, [3.4] at the centre of gravity of the container (see [4.3.2]) for GM corresponding to actual loading condition. In the absence of more precise information, a value of $0,07xB$ may be used.



**4.4 Route Dependent Factor FR for specific sea routes**

**4.4.1 (1/11/2013)**

Specific standard routes are indicated in Fig 6 to Fig 10 and the relevant Route Dependent Factors  $F_R$  are summarized in Tab 6.

At the request of the Interested Parties, specific routes other than those indicated in Fig 6 to Fig 10 may be considered by the Society on a case by case basis. In these cases, FR is to be calculated as the ratio between:

- the long-term values of the ship accelerations, calculated in accordance with Pt B, Ch 5, Sec 3, [1] for the sea states representative of the specific routes, and
- the same values of accelerations, calculated for the sea states representative of the North Atlantic as per IACS Recommendation No. 34.

**Table 5 : Route Dependent Factor  $F_R$  for specific sea routes (1/11/2013)**

Specific standard routes	Route Dependent Factor $F_R$	Reference to the Figure in this Section
Asia - Mediterranean Sea route	0,83	Fig 6
Asia - North Europe route	0,88	Fig 7
North Europe - Mediterranean Sea route	0,93	Fig 8
Asia - North America route	0,94	Fig 9
North Europe - North America route	0,97	Fig 10

**Figure 6 : Asia - Mediterranean Sea route -  $F_R = 0,83$  (1/11/2013)**



Figure 7 : Asia - North Europe route -  $F_R = 0,88$  (1/11/2013)



Figure 8 : North Europe - Mediterranean Sea route -  $F_R = 0,93$  (1/11/2013)



Figure 9 : Asia - North America route -  $F_R = 0,94$  (1/11/2013)Figure 10 : North Europe - North America route -  $F_R = 0,97$  (1/11/2013)

## 4.5 Wind forces

**4.5.1** The forces due to the effect of the wind, applied to one container stowed on above deck at the level "i", is to be obtained, in kN, from the following formulae:

- in x direction:

$$F_{X,wind,i} = 1,2h_C b_C$$

- in y direction:

$$F_{Y,wind,i} = 1,2 h_C l_C$$

where:

$h_C$  : Height, in m, of a container

$l_C, b_C$  : Dimension, in m, of the container stack in the ship longitudinal and transverse direction, respectively.

This force is only acting on the stack exposed to wind. In case of M juxtaposed and connected stacks of same height, the wind forces are to be distributed over the M stacks.

**4.5.2** In case of juxtaposed and connected stacks of different heights, the wind forces are to be distributed taking into account the number of stacks at the level considered (see example in Fig 11).

## 4.6 Forces imposed by lashing and securing arrangements

**4.6.1** The forces due to locking and/or pretensioning of lashing and securing devices are only to be considered where, in a single element, they exceed 5 kN, or where they are necessary for the correct operation of the lashing system.

## 4.7 Sea pressure

**4.7.1** In the area forward of 0,75 L from the aft end, the strength of the lashing arrangements, calculated in accordance with the requirements of this Section, is to be increased by 20 cent. Such increase is not required if

containers are protected by wave-screening structures deemed effective by the Society.

**4.7.2** Lashing of containers stowed at ship's side are to be checked considering the buoyancy force due to waves, which is to be taken equal to that obtained by considering half the volume of the lowest container, or, in the case of ships less than 100 m in length, equal to that obtained by considering the total volume of the above-mentioned container.

## 5 Determination of loads in lashing equipment and in container frames

### 5.1 Calculation hypothesis

**5.1.1** The forces to be considered are the following ones:

- for the checking of lashing and securing devices and of racking of containers: transverse forces determined according to [5.2.3] in case of containers stowed longitudinally and longitudinal forces determined according to [5.2.2] in case of containers stowed transversely
- for the checking of vertical loads in container frames: vertical forces determined according to [5.2.4] for the upright condition
- for the checking of the tipping of containers: transverse and vertical forces for the inclined condition,

determined according to [5.2.3] and [5.2.4] respectively.

**5.1.2** The calculations are based on the following assumptions:

- the loads due to ship motions (see [4.3]) are applied only on one stack
- the wind loads are applied on one stack, taking account of the number of containers exposed to wind and of the number of stacks constituting the block (see [4.5])
- the lashing of the block is schematised on one stack taking account of the number of stacks, the type and quantity of lashing devices at each securing level.

**5.1.3** If the "M" stacks of containers are connected transversely at each securing level, the determination of forces is to be carried out considering the block of containers.

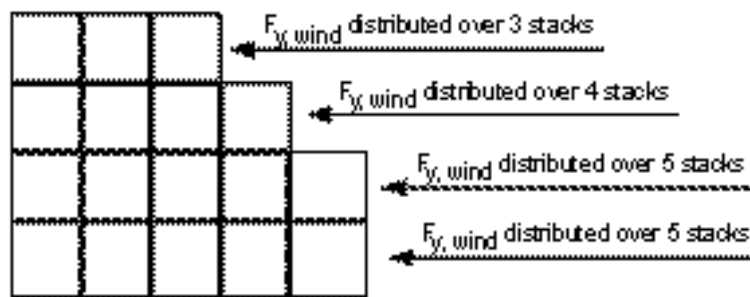
**5.1.4** If the "M" stacks of containers are not connected transversely at each securing level, the determination of forces is to be carried out one stack by one stack.

In such a case, the gaps between stacks are to be large enough to avoid contacts between container corners after deformation.

**5.1.5** Interaction between closed-end and door-end frames of the same container is not taken into account.

Pretensionning of lashing equipment, when applicable, is not accounted for.

**Figure 11 : Distribution of wind forces in case of stacks of different heights**



### 5.2 Distribution of forces

#### 5.2.1 General

For the purpose of the calculation of the lashing and securing devices, longitudinal, transverse and vertical forces are considered as uniformly distributed on the container walls.

#### 5.2.2 Longitudinal forces

The longitudinal force applied to one container is to be obtained, in kN, from the following formula:

$$F_{xi} = F_{W,x,i} + F_{x,wind,i}$$

where:

$F_{W,x,i}$  : Inertial force defined in [4.3.1] for the upright condition.

The longitudinal force is considered as subdivided on the four side longitudinal frames of the container.

#### 5.2.3 Transverse forces

The transverse force applied to one container is to be obtained, in kN, from the following formula:

$$F_{yi} = F_{W,y,i} + F_{y,wind,i}$$

where:

$F_{W,y,i}$  : Inertial force defined in [4.3.1] for the inclined condition

$F_{y,wind}$  : Wind force, if any, defined in [4.5].

The transverse force is considered as subdivided on the four end transverse frames of the container.

#### 5.2.4 Vertical forces

The vertical force applied to one container is to be obtained, in kN, from the following formula:

$$F_{zi} = F_{S,i} + F_{W,z,i}$$

where:

- $F_{S,i}$  : Still water force defined in [4.3.1]  
 $F_{W,z,i}$  : Inertial force defined in [4.3.1], for the ship in upright condition or inclined condition, as applicable.

The vertical force is considered as subdivided on the four corners of the container.

### 5.3 Containers only secured by locking devices

**5.3.1** Where the containers of a stack are secured to each other and to the base only by using locking devices fitted at their corners, the reactions on the different supports are to be determined by applying the equilibrium equations of rigid bodies, equalling to zero the sum of the forces and moments applied to the system.

**5.3.2** In particular, a calculation is to be carried out by considering the combination of vertical forces with vertical reactions induced by transverse forces, to determine whether, on some supports, reactions have a negative sign, which indicates the possibility of separation and tipping of containers.

**5.3.3** The loads resulting on containers and securing devices are not to exceed the permissible loads defined in [6].

### 5.4 Containers secured by means of lashings or buttresses

**5.4.1** When securing of containers of a stack is carried out by means of lashings, both the stiffness of the lashings (see [5.5.1]) and of the container (see [5.5.2]) are to be taken into account.

**5.4.2** The tension in each lashing may be calculated by imposing the equality of the displacement of the corner of the container to which the lashing end is secured and the lashing elongation.

**5.4.3** The loads resulting on containers and securing devices are not to exceed the permissible loads defined in [6].

## 5.5 Stiffnesses

### 5.5.1 Lashing stiffness

The stiffness of a lashing is to be obtained, in kN/mm, from the following formula:

$$K = \frac{A_e E_a}{\ell} 10^{-4}$$

where:

- $A_e$  : Cross section of the lashing, in cm<sup>2</sup>  
 $E_a$  : Modulus of elasticity of the lashing, in N/mm<sup>2</sup>, which may be obtained from Tab 6 in the absence of data on the actual value

- $\ell$  : Total length of the lashing including tensioning devices, in m.

### 5.5.2 Stiffness of containers

For the purpose of the calculation, in the absence of data on the actual values, the stiffness of containers may be obtained, in kN/mm, from Tab 7.

**Table 6 : Modulus of elasticity of lashing**

Type	$E_a$ , in N/mm <sup>2</sup>
Steel wire rope	90000
Steel chain	40000
Steel rod:	
• length < 4 m	140000
• length ≥ 4 m	180000

**Table 7 : Stiffness of containers**

Racking stiffness, in kN/mm		
Closed end	Door end	Side
128 / $H_0$	32 / $H_0$	320 / $L_0$
<b>Note 1:</b>		
$H_0$ : height of the container, in feet,		
$L_0$ : length of the container, in feet.		

## 6 Strength criteria

### 6.1 Permissible loads on containers

**6.1.1** For 20 and 40 feet containers, lashing arrangement is to be such that maximum loads on each container frame, in kN, is to be less than the values indicated in:

- Fig 12 for transverse and longitudinal racking
- Fig 13 for transverse and vertical compression (in this figure, ISO containers are those specified according to ISO 1496-1)
- Fig 14 for transverse and vertical tension.

**6.1.2** For open containers the permissible load in longitudinal frames is to be less than 75 kN in case of racking.

#### 6.1.3 (1/7/2015)

For 45 feet containers, and 48, 49, 53 feet containers, fitted on top of 40 feet, an allowable corner post of 270 kN is to be considered.

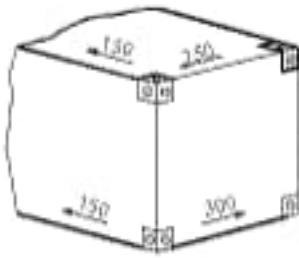
#### 6.1.4 (1/7/2015)

For containers other than mentioned in [6.1.3], lashing arrangement is to be such that maximum loads on each container frame, in kN, is to be less than:

- 2,25 R for the vertical compression
- 0,5 R for the vertical traction,

where R is equal to the sum of maximum load in the container and own mass of container.

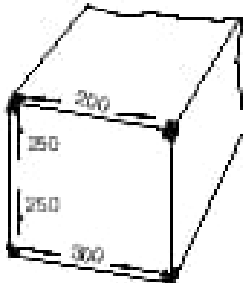
**Figure 12 : Permissible transverse and longitudinal racking loads on frames of 20' and 40' containers (1/7/2015)**



**Figure 13 : Permissible transverse and vertical compressions on frames of 20' and 40' containers**

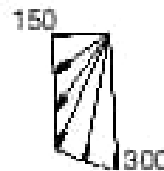


**Figure 14 : Permissible transverse and vertical tensions on frames of 20' and 40' containers**



**6.2.2** In case of a combination of forces applied on container corners, the resultant force is to be less than the value obtained, in kN, from Fig 16.

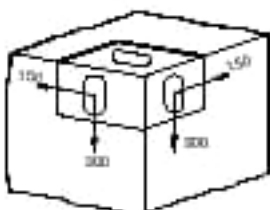
**Figure 16 : Resultant permissible load on container corners**



**6.2 Permissible loads induced by lashing on container corners**

**6.2.1** The maximum forces induced by lashing equipment and applied on container corner pieces are to be less than the values indicated, in kN, in Fig 15.

**Figure 15 : Permissible loads induced by lashing on container corners**



**6.3 Permissible loads on lashing equipment**

**6.3.1** The forces applied to each piece of lashing equipment are to be less than the safe working load (SWL) indicated by the manufacturer.

**6.4 Permissible stresses on cell guides**

**6.4.1** The local stresses in the elements of cell guides, transverse and longitudinal cross-ties, and connections with the hull structure are to be less than the following values:

- normal stress:  $150/k \text{ N/mm}^2$
- shear stress:  $100/k \text{ N/mm}^2$
- Von Mises equivalent stress:  $175/k \text{ N/mm}^2$ ,

where k is the material factor, defined in Pt B, Ch 4, Sec 1, [2.3].



## SECTION 6

## DYNAMIC POSITIONING (DYNAPOS)

### 1 General

#### 1.1 Application

##### 1.1.1 (1/7/2017)

The additional class notation **DYNAPOS** is assigned, in accordance with Pt A, Ch 1, Sec 2, [6.14.6], to ships fitted with dynamic positioning installations complying with the requirements of this Section, as follows:

- **DYNAPOS-SAM**
- **DYNAPOS-DP1**
- **DYNAPOS-DP2**
- **DYNAPOS-DP3**

For the purpose of this Section, these notations are indicated using the following abbreviations:

- **SAM** for **DYNAPOS-SAM**
- **DP1** for **DYNAPOS-DP1**
- **DP2** for **DYNAPOS-DP2**
- **DP3** for **DYNAPOS-DP3**

##### 1.1.2 (1/7/2017)

**SAM** (semi-automatic control): the control system of the installation is to be achieved by automatic conversion of the instructions issued by the operator in thruster commands: the operator's manual intervention is necessary for position keeping.

##### 1.1.3 (1/7/2017)

**DP1** (automatic control): position keeping is automatically achieved and loss of position and/or heading may occur in the event of a single failure.

##### 1.1.4 (1/7/2017)

**DP2** (automatic control): position keeping is automatically achieved, but loss of position and/or heading is not to occur in the event of a single failure in any active component or system. Single failure criteria include:

- any active component or system (generators, thrusters, switchboards, communication network, remote controlled valves, etc.),
- any static component (cables, pipes, manual valves, fitting, junction, etc.) not properly protected from external damage. Static components will not be considered to fail where adequate protection from damage is demonstrated to the satisfaction of the Society.

##### 1.1.5 (1/1/2021)

**DP3** (automatic control): position keeping is automatically achieved, but loss of position and/or heading is not to occur in case of a single failure. Single failure criteria include:

- any active component or system (generators, thrusters, switchboards, communication network, remote controlled valves, etc.),
- any static component,
- all components in any one watertight compartment and any one fire sub-division, due to fire or flooding.

Note 1: It is assumed that all active and static components are subjected to proper maintenance.

##### 1.1.6 (1/1/2021)

The additional class notation **DP PLUS** is assigned, in accordance with Pt A, Ch 1, Sec 2, [6.14.6], to ships having the additional class notation **DYNAPOS-DP2** or **DYNAPOS-DP3** and equipped with a dynamic positioning (DP) system complying with the requirements specified in [11]. An additional FMEA is needed to demonstrate the compliance with the requirements listed in [11].

##### 1.1.7 (1/7/2017)

For **DP2** and **DP3**, a single inadvertent act is to be considered as a single failure if such an act is reasonably likely.

##### 1.1.8 (1/7/2019)

Based on the single failure criteria in [1.1.4] and [1.1.5], the worst case failure is to be determined and used as the criterion for the consequence analysis.

##### 1.1.9 (1/7/2017)

The notations may be completed by the feature **SKC (L, I1, I2, I3, I4)**, defined in [10].

##### 1.1.10 (1/7/2017)

These requirements are additional to those applicable in other parts of the Rules.

##### 1.1.11 (1/7/2017)

These Rules do not cover the association of the dynamic positioning system to a position mooring system. However, if a position mooring system is used to assist the main dynamic positioning system in special circumstances of operation, this system is to be at least designed in such a way to control the length and tension of individual anchor lines remotely. An analysis of the consequences of anchor line breaks or thruster failure, according to the operational mode of the installation, is to be carried out.

### 1.2 Definitions

**1.2.1 Alarm devices:** visual and audible signals enabling the operator to immediately identify any failure of the dynamic positioning system.



**1.2.2 (1/7/2017)**

Capability plot: a theoretical polar plot of the ship's capability to maintain position in various environmental conditions (i.e. wind, waves and current from different direction), in different thruster / power configurations, including all thrusters running.

**1.2.3** Computer system: system consisting of one or more computers, associated hardware, software, peripherals and interfaces and the computer network with its protocol.

**1.2.4** Consequence analysis: software function which continuously verifies that the vessel remains in position even if the worst case failure occurs.

**1.2.5** Control modes of the DP-system:

- automatic mode (automatic position and heading control)
- joystick mode (manual position control with selectable automatic or manual heading control)
- manual mode (individual control of thrust, azimuth, start/stop of each thruster)
- auto-track mode (considered as a variant of automatic position control, with programmed movement of reference point).

**1.2.6** Dynamically positioning control system (DP- control system): the part of the dynamically positioning system that calculates position and provides thruster commands. Dynamically positioning control system is to provide adequate information to operators such that any change of status of the dynamic positioning system due to weather, equipment malfunction or operator action is clearly indicated at the permanently manned position where corrective action is possible and where limitation, if any, can be understood by operators.

**1.2.7 (1/7/2017)**

Dynamically positioned ship (DP ship): a unit or a ship which automatically maintains its position and/or heading (fixed location, relative location or predetermined track) by means of thrusters force (including shaft-lines).

**1.2.8** DP-control location: permanently manned location on board where the DP operator is able to monitor the performance of the DP system and to interface with the DP system.

**1.2.9 (1/7/2017)**

DP-control station: a control station where a group of control and monitoring devices, by means of which an operator can control and verify the performance of the DP-system, is fitted.

**1.2.10 (1/7/2017)**

Environmental conditions: environmental conditions, which include wind speed, current and wave height, under which the ship is designed to carry out intended operations. Ice loads are not taken into account.

**1.2.11** Failure: an occurrence in a component or system causing loss of component or system function and/or deterioration of functional capability to such an extent that the safety of the ship, personnel, or environment is significantly reduced.

**1.2.12** Failure mode and effects analysis (FMEA): systematic analysis of systems and sub-system to identify all potential failure modes down to the appropriate sub-system level and their consequence.

**1.2.13** Hidden failure: a failure that is not immediately evident to operations or maintenance personnel and has the potential for failure of equipment to perform an on demand function, such as protective functions in power plants and switchboards, standby equipment, backup power supplies or lack of capacity or performance.

**1.2.14 (1/7/2019)**

Joystick system: a system with centralized manual position control and manual or automatic heading control.

**1.2.15 (1/7/2019)**

Main DP-control location: the location where the main DP activities are normally performed (which may be a dedicated part of the navigation bridge or a dedicated space having the characteristics of [3.1.5]).

**1.2.16** Main DP-control station: the control station fitted in the main DP- control location.

**1.2.17 (1/7/2019)**

Position reference system: a system measuring the position of the unit.

**1.2.18** Position keeping: maintaining a desired position and/or heading and track within the normal excursions of the control system and the defined environmental conditions (wind, waver, current, etc.).

**1.2.19** Power management system (PMS): a system that ensures continuity of electrical supply under all operating conditions.

**1.2.20** Power system: all components and systems necessary to supply the DP-system with power.

**1.2.21** Redundancy: the ability of a component or system to maintain or restore its function, when a single failure has occurred. Redundancy can be achieved, for instance, by installation of multiple components, systems or alternative means of performing a function.

**1.2.22** Reference system: all components (i.e. sensors) giving position, environmental and ship attitude.

**1.2.23** Reliability: For the purpose of these rules, a component or equipment is considered reliable if it is proven to be fit for its intended service. The whole DP system reliability is considered to be achieved if its redundancy and failure tolerance, in case of DP2 or DP3 notation, is demonstrated by FMEA and proving trials.

**1.2.24 (1/7/2017)**

Station keeping number SKC: the station keeping number indicates the station keeping capability of the ship under given environmental conditions.

**1.2.25** Thruster system: all components and systems necessary to supply the DP-system with thrust force and direction.

**1.2.26 (1/7/2017)**

Time to safely terminate: the amount of time required in an emergency to safely cease operations of the ship. The time to safely terminate will vary in function of the circumstances.

**1.2.27 (1/7/2017)**

Worst Case failure (WCF): identified single failure in the DP-system resulting in maximum effect on DP capability as determined through the FMEA study. This usually relates to a number of thrusters and generators that can simultaneously fail.

**1.3 Dynamic positioning sub-systems**

**1.3.1 (1/7/2019)**

The dynamic positioning system includes all the sub-systems which effects the position keeping ability of the unit, comprising but not limited to:

- power system
- thruster system
- DP-control system (pneumatic, hydraulic, electric, electronic, as applicable)
- reference system.

**1.3.2** The power system can be subdivided in power generation, power management and power distribution and includes:

- prime movers main engine with necessary auxiliary systems (e.g. piping, fuel, cooling, starting air etc.)
- pre-lubricating and lubrication,
- generators with necessary auxiliary systems,
- switchboards, including auxiliaries powered by 24Vdc and UPS
- cabling and cable routing, including distribution of power supply to auxiliaries
- power management system, including its power supply to auxiliaries (24 Vdc, batteries and UPS)
- control systems , including its power supply to auxiliaries (24 Vdc, batteries and UPS).

**1.3.3 (1/7/2017)**

The thruster system includes:

- thrusters with drive units and necessary auxiliary systems including piping, cooling, lubrication systems, etc.
- main propellers and rudders if these are under the control of the DP-system
- thruster control system, including power supplies, (24 Vdc, batteries and UPS)
- manual thruster control system, including its power supplies (24 Vdc, batteries and UPS)
- cabling and cable routing.

**1.3.4 (1/7/2019)**

The DP-control system includes:

- computer system
- joystick system,
- control station and display system (operator panels),
- cabling and cable routing,
- power supplies (24 Vdc, batteries and UPS) and distributions.

**1.3.5 (1/7/2019)**

The reference system consists of sensors providing:

- position (i.e. position reference system),
- environmental information and
- ship attitude information regarding position and heading keeping in the specified environmental characteristics (wave, current, wind speed etc.).

**2 Documentation to be submitted**

**2.1**

**2.1.1** In addition to the drawings and specifications required by Tasneef Rules, the documents listed in Tab 1 are to be submitted.

**Table 1 : Documents to be submitted (1/1/2021)**

Systems	Documents to be submitted	I/A (1)	Notation
Dynamic positioning system	General specification	I	All
	Electrical power balance	A	All
	One-line diagram showing all the power supplies relevant to the DP system, i.e. electrical (24 Vdc, batteries and UPS), pneumatic, hydraulic, electric, electronic, as applicable	A	All
	Layout diagram showing fire and watertight subdivisions to meet DP3 requirement of resistance to worst case failure of fire and/or flooding	A	DP3

(1) A: to be submitted for approval  
I: to be submitted for information

(2) proving trials for **SAM** and **DP1** notation are to include at least:

- normal operation
- verification that any realistic single failure brings the DP system in a safe state
- verification that the local control of the equipment is maintained upon any failure of the control system.

Systems	Documents to be submitted	I/A (1)	Notation
	FMEA of the overall system, i.e. such as to integrate the results of the subsystems' FMEAs at overall DP system level (to be also kept onboard)	A	DP2, DP3
	Procedure and results of proving trials, on the basis of the FMEA, to demonstrate the required redundancy (to be also kept onboard)	A	DP2, DP3
	SKC documentation (if applicable)	A	All
	Software quality plan	I	All
	FMEA proving trial programme (based on the overall DP system FMEA)	A	DP2, DP3
	Proving trials programme	A	SAM, DP1
	Proving trial report	I	SAM, DP1
	FMEA proving trial report	I	DP2, DP3
Position keeping control stations	Layout of the control stations for all the notations	A	All
Thrusters	Documentation showing: <ul style="list-style-type: none"> <li>• thrust output and power input curves</li> <li>• response time for thrust changes</li> <li>• response time for direction changes</li> <li>• residual interaction effects, if any</li> </ul>	I	All
Main and back- up automatic dynamic positioning control systems	Control system philosophy	A	All
	Block diagram	A	All
	Documentation of user interface displays for required position reference systems	A	All
	Power supply, including electric (24 Vdc, UPS and batteries), pneumatic, hydraulic, electronic, as applicable	A	All
	List of instruments and equipment	I	All
	Environmental specifications	I	All
	Software test plan (to be also available onboard)	I	All
	Diagram of essential functions (emergency stops, ESD, mode selection etc.) with their power supplies	A	All
	System FMEA	A	DP2, DP3
	Test procedure at manufacturer premises (to be also available onboard)	A	All
	Test procedure for proving trials (to be also available onboard)	A	All
	Operation manual (to be also available onboard)	I	All
	Installation manual (to be also available onboard)	I	All
	Maintenance manual (to be also available onboard)	I	All
Independent joystick control system	Control system functional description	A	DP1, DP2, DP3
<p>(1) A: to be submitted for approval I: to be submitted for information</p> <p>(2) proving trials for <b>SAM</b> and <b>DP1</b> notation are to include at least:</p> <ul style="list-style-type: none"> <li>• normal operation</li> <li>• verification that any realistic single failure brings the DP system in a safe state</li> <li>• verification that the local control of the equipment is maintained upon any failure of the control system.</li> </ul>			

Systems	Documents to be submitted	I/A (1)	Notation
	Block diagram	A	DP1, DP2, DP3
	Documentation of user interface	A	DP1, DP2, DP3
	Power supply, including low-voltage supply (24 Vdc, UPS and batteries)	I	DP1, DP2, DP3
	List of instruments and equipment	I	DP1, DP2, DP3
	Software test plan (to be also available onboard)	I	DP1, DP2, DP3
	Test procedure at manufacturer premises (to be also available onboard)	A	DP1, DP2, DP3
	Test procedure for proving trials (to be also available onboard)	A	DP1, DP2, DP3
	Operation manual (to be also available onboard)	I	DP1, DP2, DP3
	System FMEA	A	DP2, DP3
Thruster control mode selection system	Control system functional description	A	All
	Block diagram	A	All
	Documentation of user interface	A	All
	Power supply, including electric (24 Vdc, UPS and batteries), pneumatic, hydraulic, electronic, as applicable	A	All
	List of instruments and equipment	I	All
	Environmental specifications	I	All
	Software test plan (to be also available onboard)	I	All
	Test procedure at manufacturer premises (to be also available onboard)	A	DP1, DP2, DP3
	Test procedure for proving trials (to be also available onboard)	A	DP1, DP2, DP3
	Operation manual (to be also available onboard)	I	DP1, DP2, DP3
	System FMEA	A	DP2, DP3
Position reference systems	Documentation of user interface	A	All
	Power supply, including low-voltage supply (24 Vdc, UPS and batteries)	A	All
	List of instruments and equipment	I	All
	Environmental specifications	I	All
	Software test plan (to be also available onboard)	A	DP1, DP2, DP3
	Test procedure for proving trials (to be also available onboard)	A	DP1, DP2, DP3
	Operation manual (to be also available onboard)	I	DP1, DP2, DP3
	System FMEA	A	DP2, DP3
Vertical reference, heading reference, wind and other sensor systems	Position system functional description	A	DP1, DP2, DP3
<p>(1) A: to be submitted for approval I: to be submitted for information</p> <p>(2) proving trials for <b>SAM</b> and <b>DP1</b> notation are to include at least:</p> <ul style="list-style-type: none"> <li>• normal operation</li> <li>• verification that any realistic single failure brings the DP system in a safe state</li> <li>• verification that the local control of the equipment is maintained upon any failure of the control system.</li> </ul>			

Systems	Documents to be submitted	I/A (1)	Notation
	Block diagram	A	DP1, DP2, DP3
	Documentation of user interface	A	DP1, DP2, DP3
	Power supply, including low-voltage supply (24 Vdc, UPS and batteries)	A	DP1, DP2, DP3
	List of instruments and equipment	I	DP1, DP2, DP3
	Environmental specifications	I	All
	Software test plan (to be also available onboard)	A	DP1, DP2, DP3
	Test procedure for proving trials (to be also available onboard)	A	DP1, DP2, DP3
	Operation manual (to be also available onboard)	I	DP1, DP2, DP3
	System FMEA	A	DP2, DP3
Power management system	System FMEA	A	DP2, DP3
<p>(1) A: to be submitted for approval I: to be submitted for information</p> <p>(2) proving trials for <b>SAM</b> and <b>DP1</b> notation are to include at least:</p> <ul style="list-style-type: none"> <li>• normal operation</li> <li>• verification that any realistic single failure brings the DP system in a safe state</li> <li>• verification that the local control of the equipment is maintained upon any failure of the control system.</li> </ul>			

### 2.1.2 Failure mode and Effect Analysis (FMEA) (1/7/2021)

For ships with **DP2** and **DP3** notation, compliance with the single failure criteria is to be demonstrated by means of a Failure Mode Effect Analysis (FMEA).

The FMEA of the overall system is aimed to demonstrate that, in case of single failures, systems will return to a safe situation and that systems in operation will not be lost or degraded beyond acceptable performance criteria on the basis of the **DP** notation criteria. It needs to be based on the FMEA of its subsystems, carried out by the relevant suppliers and required for approval.

Note 1: A 'safe situation' is a situation when the operation is interrupted, or will be soon interrupted, without causing position loss and leaving the ship in a state where operations can readily be resumed once the disturbance is corrected.

The FMEA should be conducted according to the "Tasneef Guide for Failure Mode and Effect Analysis", or according to a standard acceptable to the Society.

When carrying out the FMEA, the following aspects are to be considered:

- a) the FMEA is to demonstrate the fulfilment of the requirements related to all the particular operations of the ship under study;
- b) special attention is to be paid to the equipment that is more liable to originate common cause failures, i.e. interfaces with power supplies, computer-based systems and the like;
- c) the failure modes are also to include realistic operational errors;
- d) it is not to be intended that the FMEA is suitable to evaluate the software, which is to comply with Pt C, Ch 3, Sec 3;

- e) the documentation describing the FMEA, the software test and operations and the proving trials is to be kept onboard, and updated in case of modifications to equipment, hardware and/or software

## 3 Functional requirements

### 3.1 General

**3.1.1** All components in a DP-system are to be designed, constructed and tested according to the relevant applicable requirements.

#### 3.1.2 (1/7/2019)

In order to meet the single failure criteria given in [1.1.4] and [1.1.5], redundancy of components will normally be necessary as follows:

- for **DP2** notation: redundancy of all active components and protection of the static components,
- for **DP3** notation: redundancy of all active components and separation of all the static components; the two DP systems are to be located in different compartments separated by bulkheads that are A-60 fire resistant and watertight if located below the operational waterline.

**3.1.3** For **DP2** and **DP3** notation, connections between otherwise redundant and separated systems are to be kept to a minimum and made to fail to the safest condition. Failure in one system is in no case to be transferred to the other redundant system.

**3.1.4** The transfer to redundant component or system is to be automatic, as far as possible, and operator intervention should be kept to a minimum. Redundant components and system are to be immediately available so that the DP operation can be continued for such a period that the work in

progress can be terminated safely. The transfer of control is to be smooth and not result in breach of acceptable excursion criteria set for loss of position and/or heading.

**3.1.5** For **DP2** and **DP3** notation, hidden failure monitoring is to be provided on all devices where FMEA shows that a hidden failure will result in a loss of redundancy.

**3.1.6** DP-control station is to be located where operator has a good view of the external environment, working operations of the vessel and the surrounding area. At least the following equipment is to be fitted in each DP-control station, including the back-up DP-control station for **DP3** notation:

- DP-control and independent joystick control operator stations;
- manual thruster levers,
- mode change system,
- thruster emergency stops,
- means of internal communications,
- position reference systems.

**3.1.7** For **DP2** and **DP3** notation, systems not directly part of the DP-system, such as fire-fighting systems, engine ventilation, heating, air conditioning (HVAC) systems, shutdown systems, etc., failure of which could cause failure of the DP-system, are also to comply with requirements of these Rules.

**3.1.8** The main DP-control location may be a dedicated part of the navigation bridge or a dedicated space having the characteristics of [3.1.5].

**3.1.9** Means of communication are to be provided between the main DP-control location and

- a) navigating bridge,
- b) engine room and engine control room,
- c) responsible officer's accommodation,
- d) other DP-control locations.

**3.1.10** It is not acceptable to use wireless data links for essential DP services, unless specifically considered by the Society on the basis of:

- the verification of the compliance with Pt C, Ch 3, Sec 3,
- an engineering analysis, which includes Risk Analysis, carried out in accordance with an International or National Standard, and
- an appropriate test campaign, aimed at demonstrating an equivalent level of safety of conventional cable systems.

## 3.2 Power system

### 3.2.1 (1/7/2017)

The electrical installations are to be designed, constructed and tested according to the relevant applicable requirements, in particular for:

- rotating machines
- transformers
- switchboards
- electrical cables
- batteries and/or UPS
- convertors
- electronic equipment.

All the above equipment is to include its associated auxiliaries and control system and relevant power supply, i.e. electric (24 Vdc, UPS and batteries), pneumatic, hydraulic, electronic, as applicable.

**3.2.2** The power system is to have an adequate response time to power demand changes.

### 3.2.3 (1/7/2017)

For **SAM** and **DP1**, the power system, including UPS, batteries and 24Vdc, needs not to be redundant.

### 3.2.4 (1/7/2017)

For **DP2** notation, the power system, including UPS, batteries and 24Vdc, is to be divisible into two or more systems such that, in the event of failure of one system, at least one other system will remain in operation and provide sufficient power for station keeping. The power system may be run as one system during operation, but it is to be arranged with bus-tie breaker(s) to separate the systems automatically upon failures which could be transferred from one system to another, including, but not limited to, overload and short-circuits.

### 3.2.5 (1/7/2017)

For **DP3** notation, the power system, including UPS, batteries and 24Vdc, is to be divided into two or more systems such that in the event of failure of one system, at least one other system will remain in operation and provide sufficient power for station keeping. The divided power system is to be located in different spaces separated by A-60 class division. Where the power systems are located below the operational waterline, the separation is to be also watertight. Bus-tie breakers are to be kept opened during **DP3** operations, unless equivalent integrity of power operation can be demonstrated, in compliance with [3.1.3].

### 3.2.6 (1/7/2019)

For **DP2** and **DP3** notation, the following applies:

- a) the power available for position keeping is to be sufficient to maintain the ship in position after the worst case failure occurring;
- b) a power management system (PMS) is to be provided and is to be redundant in such a way failure of the power management system is not to produce a failure exceeding the worst case failure, to be demonstrated

through FMEA. A failure in the power management system is to initiate an alarm in the DP-control station.

For **DP3** notation, the requirements as per a) and b) above are to be complied with also in case of fire or flooding in one compartment.

**3.2.7** The power management system is to be continuously supplied by means of an uninterruptible power supply system (UPS). Where power management system is required to be redundant, the redundancy is also to be achieved also by the relevant power supply.

**3.2.8** (1/7/2017)

The power management system is to be capable of:

- enabling quick supply of active power to consumers in all operating conditions including generator failure or change of thruster configuration;
- maintaining a proper balance between power demand and power generating configuration, in order to avoid a black-out, following sudden load changes resulting from single failures or equipment failures
- disconnecting or reducing automatically the excess load in case of inadequate available power in order to maintain power to thrusters.

### 3.3 Thruster system

**3.3.1** The thrusters are to be designed, constructed and tested according to the relevant applicable requirements. Care is to be taken to minimize interferences with the other thrusters or parts of the ship that may reduce the available thrust.

**3.3.2** The thruster system is to provide adequate thrust in longitudinal and lateral directions, and provide yawing moment for heading control.

**3.3.3** For **DP2** and **DP3** notation, the thruster system is to be connected to the power system in such a way that [3.3.2] can be complied with even after failure of one of the power systems and the thrusters connected to that system.

**3.3.4** Each thruster is to be capable of being individually remotely controlled independently of the DP- control system.

**3.3.5** Failure of a thruster system including pitch, azimuth and/or speed control is not to cause an increase in thrust magnitude or change in thrust direction.

**3.3.6** (1/7/2019)

A hardwired independent emergency stop is to be provided for each thruster, adequately protected against inadvertent operation and arranged in the DP control stations. The emergency stop is to be arranged with a separate circuit for each thruster. The thruster emergency stop system is to have loop monitoring. For **DP3**, the effects of fire and flooding on the emergency stop system are also to be considered (e.g. a signal of presence of fire or gas is not to stop engine room ventilation).

### 3.4 DP Control system

**3.4.1** For the purpose of granting the **SAM** notation the following applies:

- the control system is to indicate the position and heading of the unit to the operator and control settings are to be displayed;
- the control device handle is to have a well-defined neutral position (no thrust).

**3.4.2** For **DP1**, **DP2** and **DP3** notations, the ship is to be fitted with an automatic control and with a stand-by manual control equivalent to the control system required for **SAM** notation.

**3.4.3** The DP-control station is to display information from the power system, thruster system and DP-control system to ensure that these systems are functioning correctly. Information necessary to safely operate the DP-system are to be visible at all times. Other information is to be available upon operator request.

**3.4.4** Where several control stations are provided, Pt C, Ch 3, Sec 2, [3.3] is to be complied with.

**3.4.5** Display systems and the DP-control station are to be based on sound ergonomic principles which promote proper operation of the system. The DP-control system is to provide for easy accessibility of the control mode (i.e. manual joystick or automatic DP-control of thrusters, propellers and rudders, if part of the thruster system). The active control mode is to be clearly displayed.

**3.4.6** For **DP2** and **DP3** notation, operator controls are to be designed so that no single inadvertent act on the operator's panel can lead to a critical condition, such as loss of position and/or heading.

**3.4.7** Alarms and warnings for failures in systems interfaced to and/or controlled by the DP-control system (see Tab 3) are to be audible and visual. A record of their occurrence and of status changes is to be provided together with any necessary explanations.

**3.4.8** The DP-control system is to prevent failures being transferred from one system to another. The redundant components are to be so arranged that failed component(s) can be easily isolated so that the other component(s) can take over smoothly with no loss of position and/or heading.

**3.4.9** In the event of failure of the DP-control, it is to be possible to control the thrusters manually, by a common independent joystick or by manual control levers. If an independent joystick is provided with sensor inputs, failure of the main DP-control system is not to affect the integrity of the inputs to the independent joystick.

**3.4.10** (1/7/2017)

The installed software is to be produced in accordance with an appropriate international quality standard recognised by the Society.

### 3.5 Computer system

**3.5.1** Computer systems are to be arranged as follows, depending on class notation:

- for **DP1** notation, the DP-control system needs not be redundant,
- for **DP2** notation, the DP-control system is to consist of at least two independent computer systems; common facilities such as self-checking routines, data transfer arrangements and plant interfaces are not to be capable of causing the failure of both / all systems,
- for **DP3** notation, the main DP-control system is to consist of at least two independent computer systems with self-checking and alignment facilities; common facilities such as self-checking routines, data transfer arrangements and plant interfaces are not to cause failures at both/all systems. In addition to the aforesaid main DP-control systems, one further back-up DP-control system is to be provided, arranged in a separate space. An alarm is to be given if any computer fails or is not ready to take over in case of necessity.

**3.5.2** Redundant computer systems are to be arranged with automatic transfer of control after a detected failure in one of the computer systems. The automatic transfer of control from one computer system to another is to be smooth with no loss of position and/or heading.

**3.5.3** For **DP3** notation, the back-up DP-control system is to be located in a space separated by A-60 class division from the main DP-control location. During DP-operation, this back-up DP-control system is to be continuously updated by input from the sensors, position reference system, thruster feedback, etc., and is to be ready to take over control. The switch-over of control to the back-up DP-control system is to be manual, situated in the space where the back-up DP-control system is located and is not to be affected by a failure of the main DP-control system input/output signals to and from the back-up DP-control system.

**3.5.4** For **DP2** and **DP3** notation, the DP-control system is to include a software function, normally known as "consequence analysis", which continuously verifies that the vessel will remain in position even if the worst case failure occurs. This analysis is to verify that the thrusters, propeller and rudders, remaining in operation after the worst case failure, can generate the same resultant thruster force and moment as required before the failure. The consequence analysis is to provide an alarm if the occurrence of a worst case failure would lead to a loss of position and/or heading due to insufficient thrust for the prevailing environmental conditions (e.g. wind, waves, current, etc.). For operations which will take a long time to safely terminate, the consequence analysis is to include a function which simulates the thrust and power remaining after the worst case failure, based on input of the environmental conditions.

**3.5.5** Each computer system is to be isolated from other onboard computer systems and communication systems to ensure the integrity of the DP system and command inter-

faces. This isolation is to be achieved via hardware and/or software systems and by physical separation of cabling and communication lines. Robustness of the isolation is to be verified by analysis and proven by testing. Specific safeguards are to be implemented to ensure the integrity of the computer systems in order to prevent the connection of unauthorized devices or systems.

### 3.6 Position reference system

**3.6.1** The position reference systems is to be selected with due consideration to operational constraints and requirements.

**3.6.2** The ship is to be equipped with suitable position reference system in accordance with the additional class notation:

- for **SAM** notation, one reference system may be provided;
- for **DP1** notation, at least two independent position reference systems are to be installed and simultaneously available to the DP-control system during operation;
- for **DP2** and **DP3** notation, at least three independent position reference systems are to be installed and simultaneously available to the DP-control system during operation.

**3.6.3** For **DP3** notation, at least one of the position references system is to be connected directly to the back-up DP-control system and separated by A-60 class division from the other position reference systems.

#### 3.6.4 (1/7/2017)

When two or more position reference systems are required, they are of different type, based on different principles and suitable for the operating conditions.

**3.6.5** The position reference systems are to produce data with adequate accuracy and repeatability for the intended DP operation.

**3.6.6** The performances of position reference systems are to be monitored and warnings are to be provided when the signals from the position reference system are either incorrect or substantially degraded.

**3.6.7** Visual and audible alarms are to be activated when the unit deviates from the set heading or from the working area determined by the operator.

**3.6.8** Indication of the position reference system in operation is to be given to the operator.

**3.6.9** When the signals from position reference system can be altered by the movement of the unit (i.e. roll, pitch, heave and yaw), a vertical reference sensors (VRS) or a motion reference unit (MRU) with sensors of appropriate characteristics with regard to the expected accuracy of position measurement is to be provided. The VRS/MRU is to be redundant for **DP2** and **DP3** notations, in accordance with **DP2** and **DP3** requirements.



**3.6.10 (1/7/2019)**

Different types of position reference systems may be used, e.g. acoustic position references, taut wires system, GPS or DGPS, etc.:

- When acoustic position references are used, hydrophone is to be chosen for minimising influence of mechanical and acoustical disturbance on the transmission channels, such as propeller noise, spurious reflection on the hull, interference of riser, bubble or mud cluster on the acoustic path. The directivity of transponders and hydrophones is to be compatible with the availability of the transmission channels in all foreseeable operational conditions. It is to be possible to select the frequency range and the rate of interrogation according to prevailing acoustical conditions, including other acoustical system possibly in service in the area.
- When taut wires system is used, materials used for wire rope, tensioning and auxiliary equipment are to be appropriate for marine service. The anchor weight is to be designed to avoid dragging on the sea floor and is not to induce, on recovery, a wire tension exceeding 60% of its breaking strength, and the capacity of the tensioner is to be adapted to the expected movement amplitude of the unit.
- When a GPS or DGPS is used, it is to be designed according to IMO resolutions A.694(17), A.813(19) and MSC.148(77) for communication and performance standards. The equipment is to be either type approved or MED, as applicable, and accepted by the Flag. The relevant certificates are to be readily available and in course of validity. For other reference systems the principle of equivalency is applied.

Other position reference systems may be used. Whatever the chosen principle (for example, hyperbolic or polar determination), the accuracy of the position measurement is to be satisfactory in the whole operational area.

**3.6.11** Location of the receiving equipment is to be chosen so as to minimise, as far as practicable, masking effects and interferences.

**3.6.12** Systems that need periodical adjustment such as those based upon inertial navigation, Doppler effect, deep taut-wire with riser angle detection, are to be integrated with other reference system giving continuous output without appreciable offset. These systems are subject to a special examination by the Society and confirmed after onboard survey.

**3.7 Ship sensors**

**3.7.1** Ship sensors are at least measure vessel heading, ship motion, wind speed and direction.

**3.7.2** For **DP2** and **DP3** notation, signals from ship sensors are to be based on three systems serving the same purpose (e.g. this will result in at least three heading reference sensors being installed).

**3.7.3** For **DP3** notation, one of each type of sensors is to be connected directly to the back-up DP-control system

and separated by A-60 class division from the other sensors. If the data from these sensors is passed to the main DP-control system for their use, this system is to be arranged so that a failure in the main DP-control system cannot affect the integrity of the signals to the backup DP-control system.

**3.7.4** Sensors used for the same purposes, connected to redundant systems, are to be arranged independently so that failure of one will not affect the others.

**3.7.5** Sensors are to be self-monitoring. Inputs from sensors are to be monitored in order to detect possible faults, notably relative to the signal trend. Analogue sensors are to be monitored for wire break, short-circuit or low insulation.

**3.7.6** Inputs from simultaneously in use sensors are to be compared in order to detect significant discrepancy between them.

**3.7.7** Wind speed is to be recorded by suitably located wind sensors so that they are not subject to vessel turbulence or interference for example from crane, helicopter and platform.

**3.7.8** For ship's heading:

- for **SAM** notation, one gyrocompass or another heading measurement unit of equivalent accuracy is to be provided;
- for **DP1** notation, two gyrocompasses or other sensors of equivalent accuracy are to be provided;
- for **DP2** and **DP3** notation, three gyrocompasses or other sensors of equivalent accuracy are to be provided.

**4 Power supply system****4.1**

**4.1.1** The automatic DP-control system and associated reference system are to be powered by uninterruptible power system unit (UPS), complying with Pt C, Ch 2, Sec 7, [3].

**4.1.2** UPS battery capacity is to be provided for a minimum of 30 minutes operation following the failure of the power supplies.

**4.1.3** For the **DP2** and **DP3** notation, UPS provided for DP-control system and associated reference system, are to be arranged such that no single failure to one DP-control system and associated reference system, interrupts the power supplies to the redundant control systems and associated reference systems. For **DP3** notation also fire or flooding in one compartment is not to interrupt the power supplies to the redundant control system and associated reference system. The UPS for redundant systems are to be supplied by individual separate circuits from independent sections of the main switchboard or from two independent section boards, each one powered by separate feeders from independent sections of the main switchboard.

**4.1.4** For **DP3** notation, the back-up DP-control system and its associated reference system are to be provided with a dedicated UPS, located according to [3.5.3].

Table 2 : DP System configuration (1/7/2019)

Subsystems or components		Class Notation			
		SAM	DP1	DP2	DP3
POWER SYSTEM	Main switchboard	- (1)	- (1)	1 with two busbars connected by normally closed bustie	At least 2 arranged In separate compartments
	Bus-tie breaker	- (1)	- (1)	1	2 kept open, one in each main switchboard
	Distribution system	- (1)	- (1)	Redundant arrangement	Redundant arrangement in separate compartments
	Power management system (PMS)	Not required	Not required	Redundant	Redundant, in separate compartments
THRUSTER SYSTEM	Thrusters	Not redundant	Not redundant	Redundant arrangement	Redundant arrangement in separate compartments
DP-CONTROL SYSTEM	Computer System	-	1	2	3, 1 of them connected to the back-up DP-control system
	Joystick with automatic heading	- (2)	- (2)	required	required
REFERENCE SYSTEM	Position Reference system	1	2	3	3, 1 of them connected to the back-up DP-control system
	VRS/MRU	1	1	3	3, 1 of them connected to the back-up DP-control system
	Wind sensor	1	2	3	3, 1 of them connected to the back-up DP-control system
	Gyro or ship heading sensor	1	2	3	3, 1 of them connected to the back-up DP-control system
UPS UNIT		-	1	2	3, 1 of them located in the back-up control room

(1) According to Pt C, Ch 2, Sec 3, [3.5].  
(2) Where provided, failure of the joystick is to bring the system in the safe situation.

## 5 Cables and piping systems

### 5.1

**5.1.1** For DP2 notation, the piping systems for fuel, lubrication, hydraulic oil, water, pneumatic circuits and cables are to be located with due regard to fire hazards and mechanical damages also deriving from operational activities.

**5.1.2** For DP3 notation, cables for redundant equipment or systems are not to be routed through the same compartments. However, electrical cables of one system may be considered to remain operational if routed through the compartment of the other redundant system, provided that:

- the cables of redundant systems are not routed together;
- the cables comply with standard IEC 60092-359, in order to be considered operational during a flooding scenario, and they have no connections, no joints, no equipment connected to them within the space; if connections, joints and devices are fitted, they are to have a degree of protection IPX8 in accordance with standard IEC 60529 and
- the cables are fire-resistant type complying with standards IEC 60331-1 and IEC 60331-2 and they have no connections, joints and equipment connected to them within the space or, alternatively, they are contained in a trunk closed at all boundaries constructed to "A-60" standard.

Note 1: the installation of cables is to be suitable to support their survival in a fire casualty and during fire fighting efforts.

**5.1.3** For DP3 notation, redundant piping systems (i.e. piping for fuel, cooling water, lubrication oil, hydraulic oil, etc.) are not to be routed through the same compartments.

However, piping system of one system may be considered to remain operational if routed through the compartment of the other redundant system, provided that:

- they are not routed together;
- they are contained in a trunk closed at all boundaries constructed to "A-60" standard.

## 6 Alarm and Monitoring System

### 6.1

#### 6.1.1 (1/7/2017)

An alarm and monitoring system is to be provided, in accordance with the applicable requirements of Pt C, Ch 3, Sec 2, reflecting the status of the DP system. In particular the system is to give indications, alarms and/or warnings at the DP-control stations, including the back-up DP-control station for DP3 notation, in case the parameters specific for the DP system assume abnormal values or for any event which can affect the DP system.

A minimum set of alarms and indications is given in Tab 3.

#### 6.1.2 (1/7/2017)

The alarm and monitoring system is to be supplied by UPS.

**Table 3 : Alarms and monitoring system (1/7/2019)**

Power management system (PMS)	A failure in the power management system is to initiate an alarm in the DP-control station.
DP Control system and position reference system	The DP-control station is to display information from the power system, thruster system and DP-control system to ensure that these systems are functioning correctly. Information necessary to safely operate the DP-system are to be visible at all times. Other information is to be available upon operator request.
	The active control mode is to be clearly displayed.
	Alarms and warnings for failures in systems interfaced to and/or controlled by the DP-control system (see Tab 3) are to be audible and visual. A record of their occurrence and of status changes is to be provided together with any necessary explanations.
	The performances of position reference systems are to be monitored and warnings are to be provided when the signals from the position reference system are either incorrect or substantially degraded.
	Visual and audible alarms are to be activated when the unit deviates from the set heading or from the working area determined by the operator.
Computer system	An alarm is to be given if any computer fails or is not ready to take over in case of necessity.
	The consequence analysis is to provide an alarm if the occurrence of a worst case failure would lead to a loss of position and/or heading due to insufficient thrust for the prevailing environmental conditions (e.g. wind, waves, current, etc.).

## 7 Software

### 7.1

**7.1.1** The software is to comply with Pt C, Ch 3, Sec 3, as applicable.

**7.1.2** A back-up copy of the current release is to be available onboard.

**7.1.3** (1/7/2017)

Modifications or updates of the software are to be carried out by authorized personnel, according to a specific management of change. A copy of the documentation that illustrates the modifications performed and the relevant management of change is to be kept onboard.

**7.1.4** (1/7/2019)

Appropriate security measures are to be taken to avoid inadvertent or malicious misuse of the software. In particular, the following actions are deemed not acceptable by the Society:

- remote maintenance;
- onboard maintenance, or use of removable media/storage devices, by non-authorized personnel.

Note 1: software maintenance includes checking, updating, re-configuring, or upgrading the software in order to prevent or correct failures, maintain regulatory compliance and/or improve performance.

Note 2: a malware check should be performed on the device to be used before the maintenance is carried out and confirmation that this check has been performed is to be recorded in the management of change.

**7.1.5** A key figure responsible for the integration of the software of the DP-subsystems should be identified

**7.1.6** The compatibility of individual equipment of the DP subsystems is to be demonstrated.

**7.1.7** Data communication links are to comply with requirements of Pt C, Ch 3, Sec 3. For **DP2** and **DP3** notation, overloading of the data communication link in one system is never to be transferred to the other redundant system.

## 8 Operational requirements

### 8.1 General

**8.1.1** Before every DP-operation, the DP-system is to be checked according to the vessel specific location checklist(s) to make sure that the DP-system is functioning correctly and that the system has been set up for the appropriate equipment class.

**8.1.2** During DP-operations, the system is to be checked at regular intervals according to a vessel specific watch-keeping checklist.

**8.1.3** (1/7/2019)

For **DP2** or **DP3** notation, DP operations are to terminate when the environmental conditions (e.g., wind, waves, current, etc.) are such that the DP-vessel will no longer be able

to keep position if the single failure criterion applicable to the DP notation occurs. In this context, deterioration of environmental conditions and the necessary time to safely terminate the operation is also to be taken into consideration. This is to be checked by way of environmental envelopes if operating in **DP1** and by way of an automatic means (e.g. consequence analysis) if operating in **DP2** or **DP3** notation.

**8.1.4** The necessary DP-operating instructions are to be kept on board. In this context, deterioration of environmental conditions and the necessary time to safely terminate the operation and consequence of loss of position should also be taken into consideration.

**8.1.5** DP capability polar plots are to be produced to demonstrate position keeping capacity for fully operational and post worst case single failure conditions. The capability plots is to represent the environmental conditions at the area of operation and the mission specific operational condition of the ship.

**8.1.6** (1/1/2022)

The following checklist, test procedures and instructions are to be incorporated into the vessel specific DP operation manuals:

- location checklist
- watch-keeping checklist
- DP-operation instructions
- tests and procedures
- example of tests and procedures after modifications and non-conformities
- black-out recovery procedure
- list of critical components
- operating modes
- capability plot.

Reports of tests and record of modification or equivalent are to be kept on board and made available during periodical inspections.

## 9 Testing

### 9.1 General

**9.1.1** Before a new installation, or any alteration or addition to an existing installation, is put into service, the DP system equipment is to be tested in accordance with [9.2] , [9.3].

**9.1.2** When deemed necessary by the attending surveyor, tests additional to those listed above may be required.

### 9.2 Type approved components

**9.2.1** The following components are to be type tested or type approved according to the tests listed in Pt C, Ch 3, Sec 6, Tab 1, as far as applicable:

- DP-control system
- Independent joystick control system with auto heading
- Sensors
- Thruster control system.

**9.2.2** All the other equipment in the DP-system, not mentioned in [9.2.1], is to be type tested or type approved according to requirements of Pt C, Ch 2, Sec 15, [2.1.1], as required for primary essential services.

### 9.3 Sea trials

**9.3.1** An initial survey is to be carried out, including a complete survey of the DP-system to ensure full compliance with the applicable Rules. It is also to include a complete test of all systems and components and the ability to keep position after single failures in relation with the assigned additional class notation. The type of test carried out and results are to be documented and kept on board.

At least the following tests are to be performed:

- Reference System  
The reference systems, including all sensors, are to be tested. Failures of sensors is to be simulated in order to verify the effects on the system.
- Thrusters System  
Functional tests of control and alarm systems of each thruster are to be carried out.
- Mode Change system  
The different control modes are to be tested. Proper operation of mode selection is to be verified.
- UPS system  
The capacity of the UPS batteries are to be tested.
- Thruster emergency stop  
The operation of the emergency stop is to be tested.
- DP-control system  
The DP-control system tests are to be carried out in relation to the worst case failure relevant to each assigned additional class notation.
- Alarm System  
Proper functioning of the alarm system is to be tested.
- Means of communication  
Proper functioning of means of communication is to be tested.

### 9.4 FMEA proving trials

#### 9.4.1 (1/7/2019)

For DP2 and DP3 notation, proving trials in order to check the results of FMEA tests are to be carried out to the satisfaction of the attending Surveyor. The test procedures are to simulate realistic failures, as far as practicable. After completion of the DP proving trials, the FMEA proving trial report is to be kept on board.

## 10 Station keeping capability feature SKC

### 10.1 Definition

#### 10.1.1 (1/7/2017)

The feature SKC may be associated to each of the class notations SAM, DP1, DP2 and DP3 and provides informa-

tion about the position keeping ability of the ship at the most unfavourable heading for specified limiting environmental conditions, considering:

- no failures, applicable for all the DP class notations;
- the worst case single failure, applicable for DP2 and DP3.

#### 10.1.2 (1/7/2017)

The feature SKC is to be provided in the form SKC (L, I1, I2, I3, I4), where:

- L indicates the location considered for defining the environmental conditions used for the assessment:
  - "STD" is to be indicated if the standard reference environmental conditions reported in [10.3.1] are used;
  - "IMCA" is to be indicated if the environmental conditions refer to the North Sea and the correlations among wave height, period and wind speed are derived from IMCA M 140,
  - the identification of the specific geographic area is to be indicated when relevant
- index I1 indicates the capability of maintaining the position considering:
  - all thrusters and rudders in normal operational conditions
  - directions of the environmental forces over the whole 360° heading range
- index I2 indicates the capability of maintaining the position considering:
  - the worst case single failure
  - directions of the environmental forces over the whole 360° heading range
- index I3 indicates the capability of maintaining the position considering:
  - all thrusters and rudders in normal operational conditions
  - directions of the environmental forces in the ±30° heading range
- index I4 indicates the capability of maintaining the position considering:
  - the worst case single failure
  - directions of the environmental forces in the ±30° heading range.

#### 10.1.3 (1/7/2017)

Indices I1, I2, I3 and I4 refer to the wind speed Beaufort scale, as reported in Tab 4, and indicate the highest environmental conditions at which the ship's station keeping capability is verified. The relevant wave heights, wave periods and current are specified in [10.3.1], in IMCA M 140 or are to be selected based on the specific geographic area L.

**Table 4 (1/7/2017)**

BF N	SKC Index	Mean Wind Speed $V_w$ [m/s]
1	1	1,5
2	2	3,4
3	3	5,4
4	4	7,9
5	5	10,7
6	6	13,8
7	7	17,1
8	8	20,7
9	9	24,4
10	10	28,4
11	11	32,6

**10.2 Documentation to be submitted**

**10.2.1 (1/7/2017)**

The following documentation is to be submitted for the purpose of the assignment of the feature SKC:

- General arrangement (including deck superstructure)
- Line plan
- operational location and environmental conditions considered for the assessment, if applicable; documentation

**Table 5 (1/7/2017)**

SKC	Mean Wind Speed $V_w$ [m/s]	Sig. Wave Height $H_s$ [m]	Zero-crossing Period $T_z$ [s]	Current Speed $V_c$ [m/s]
1	1,5	0,1	2,5	0,25
2	3,4	0,4	3,0	0,50
3	5,4	0,8	4,0	0,75
4	7,9	1,3	4,5	0,75
5	10,7	2,1	5,5	0,75
6	13,8	3,1	6,0	0,75
7	17,1	4,2	6,5	0,75
8	20,7	5,7	7,0	0,75
9	24,4	7,4	7,5	0,75
10	28,4	9,5	8,0	0,75
11	32,6	12,1	8,5	0,75

**10.3.2 (1/7/2017)**

Wind, wave and current directions are to be considered coincident.

**10.3.3 (1/7/2017)**

Wind speed refers to the 10-minute mean at a height of 10 meters above water surface. A coefficient of 1,1 can be used for converting the 10-minute mean to the 1-minute mean. Wind speed is assumed uniform in space.

on their relevance with respect to the operational location

- basin and tunnel test results or reports of the calculations performed
- details of waves drift loads on ship or unit
- details of wind loads on ship or unit
- details of current load on ship or unit
- details of thruster layout
- details of thrust power (including polar distribution of thrust as a function of heading for both intact and one thruster failure mode). This should take into consideration the interaction between thrusters, thrusters and hull, thrusters and current
- rudder details, if relevant
- thruster/rudder management logic.

**10.3 Standard environmental conditions**

**10.3.1 (1/7/2017)**

The limiting environmental data listed in the following Tab 5 are to be used for the definition of the SKC indices in standard reference conditions.

**10.3.4 (1/7/2017)**

Current direction and speed are assumed constant in time and uniform in space.

**10.3.5 (1/7/2017)**

The wave drift forces are to be derived for irregular sea states described by a Pierson Moskowitz wave spectrum. A  $\cos^2$  spreading function is to be used.

## 10.4 Site specific environmental conditions

### 10.4.1 (1/7/2017)

The indices of the feature SKC are to be defined based on the limiting wind speed, as specified in [10.1.3].

### 10.4.2 (1/7/2017)

The combination of wind speed, wave height, wave period and current speed, as well as the wave spectrum and spreading function considered for the analysis are to be relevant for the location analysed. Wind, waves and current can be not collinear. Each SKC index derives from the most unfavourable combination.

### 10.4.3 (1/7/2017)

If the limiting environmental conditions refer to the North Sea and correlations among wave height, wave period, wind speed, current speed, as well as wave spectrum and spreading function are derived from IMCA M 140.

## 10.5 Assessment of the forces

### 10.5.1 (1/7/2017)

Environmental forces (wind, wave drift and current loads), thrust and rudder forces are to be evaluated through tunnel and tank model tests, computational fluid dynamics calculations or other recognised methods.

### 10.5.2 (1/7/2017)

The assessment of the environmental forces over the heading range of interest has to be performed with a minimum resolution of 10°.

## 11 DP PLUS notation

### 11.1 Application

#### 11.1.1 (1/1/2021)

The main objective of the **DP PLUS** notation is to increase reliability, performance, protection and detection functions of DP systems during the operative profiles of the ship.

#### 11.1.2 (1/1/2021)

The functions and features requested to obtain the **DP PLUS** notation are not intended to mitigate the worst case failure defined for a ship having the **DYNAPOS** notation

#### 11.1.3 (1/1/2021)

The **DP Plus notation** may be assigned as follows, depending on different functions and operating capability of the DP system:

- **DP PLUS-DFS**
- **DP PLUS-FFP**
- **DP PLUS-PRD**

#### 11.1.4 (1/1/2021)

The **DP PLUS** notation may allow different operative modes of DP system during the DP operation of the ship, provided that these operative modes are addressed in the risk assessment.

#### 11.1.5 (1/1/2021)

Any limitations resulted by the risk assessment are to be clearly understood by ship's Master. The features of the **DP PLUS** notation need to be evaluated during DP operation according to the criteria listed in paragraph 4 of IMO circular MSC.1/Circ. 1580.

## 11.2 General

### 11.2.1 (1/1/2021)

For the purpose of this Section, the following abbreviations are used to indicate the notations listed in [11.1.3]:

- **DFS** for **DP PLUS-DFS**
- **FFP** for **DP PLUS-FFP**
- **PRD** for **DP PLUS-PRD**

### 11.2.2 (1/1/2021)

The **DFS (Dual Feeding System)** notation allows the dual feeding operation of thrusters during DP operations. This notation is assigned when power system of the thrusters complies with the requirements in [11.3] that are beyond those for the **DYNAPOS** notations.

### 11.2.3 (1/1/2021)

The **FFP (Fire and Flooding Protection)** notation enhances fire and flooding tolerance of machinery space of ships having **DP2** class notation; and increases the fire and flooding segregation of machinery space of ships having **DP3** class notation. This notation is assigned when the fire and flooding arrangement and segregation comply with the requirements in [11.4] that are beyond those for the **DYNAPOS** notations.

### 11.2.4 (1/1/2021)

The **PRD (Predictive)** notation allows operative conditions with reduced fuel consumptions due to the following automation capabilities:

- capability of detection and protection of the main switchboard allowing closed bus mode or island mode operations;
- capability of generators and auxiliary systems allowing standby of generators during low risk operating profile.

The low risk operating profile refers to Task Appropriate Mode (TAM) of IMCA Guideline.

This notation is assigned when the power generation system and the power distribution of the main switchboard comply with the requirements in [11.5] that are beyond those for the **DYNAPOS** notations.

## 11.3 Functional requirements for DFS notation

### 11.3.1 (1/1/2021)

The notation **DFS** can be added to the **DYNAPOS DP2** and **DP3** notations on a case-by-case basis.

### 11.3.2 (1/1/2021)

For **DP2 DFS** notation, dual feeding of thrusters and/or propulsion engines from different redundant systems may be accepted on a case-by-case basis, taking into account the operating profile of the vessel (refers to Task Appropriate Mode (TAM) of relevant IMCA Guideline) and as long as the following conditions are met:

- a) any failure in the dual feed system is not to propagate to any redundant system and any failure in each redundant system is not to propagate to dual feed system. In order to mitigate the effects of hidden failures, a minimum of two independent protections for each feeding, both

capable of isolating upon failure, is arranged in each power supply line.

- b) The dual-feed DP equipment is readily available at the power required for its operating profile and no power discontinuity or manual intervention is allowed in case of loss of a supply line.
- c) The correct operation of both supply lines is monitored by each DP control station and an alarm is provided in case of power failure. Test procedure is provided and included in DP trials manual.
- d) The startup and any necessary reset after shutdown is performed from the DP control station.
- e) Each dual-feed DP equipment is fitted with its own independent auxiliary system in order to avoid the possibility of common fault in case of its failure.
- f) Auxiliary and control systems are continuously supplied from a battery or by means of an UPS unit.
- g) Automatic restart of DP equipment after failure or trip is prevented. Test procedure is provided and included in DP trials manual.
- h) Selectivity and voltage-dip ride-through capabilities are documented. Test procedures are provided and included in DP trials manual.
- i) Common equipment of the dual-feed installation is located in a dedicated space separated by bulkheads that are A-60 fire resistant and watertight if located below the operational waterline.

#### 11.3.3 (1/1/2021)

For **DP3-DFS** notation, in addition to the above conditions, also the following is to be complied with:

- A minimum of three independent protections for each feeding, both capable of isolating upon failure and arranged in different watertight compartment and fire subdivision spaces (see [1.1.5]), are arranged in each power supply line.
- Discrimination and voltage-dip ride-through capabilities are verified by live testing.
- The common equipment is located in a dedicated space separated by the spaces of the redundant systems by bulkheads that are A-60 fire resistant and watertight if located below the operational waterline.
- Cables of dual feeding are separated as far as practicable: they are to follow different routes separated both vertically and horizontally, as far as practicable, throughout their entire length.

### 11.4 Functional requirements for FFP notation

#### 11.4.1 (1/1/2021)

The notation **FFP** can be added to the **DYNAPOS DP2** and **DP3** notations on a case-by-case basis.

#### 11.4.2 (1/1/2021)

For ships having **DP2** class notation, the following conditions are to be met:

- a) Physical segregation is to be provided between any redundancy group or main equipment.
  - Redundancy group means a group of equipment that contribute to the redundancy level of DP system. Equipment that constitute the redundancy group results from the FMEA document.
  - Main equipment means a machinery or device, including its auxiliaries, which take part of DP components.
  - Main equipment may result from the major fault conditions based on the from the FMEA document.
  - Main equipment or redundancy group may be not defined based on the FMEA document on the case by case basis but according to the service notation of the ship.
- b) A-60 separation is to be provided between redundancy groups.
- c) A-0 separation is to be provided between different main equipment redundancy groups.
- d) Cable or pipe passages between redundancy groups are to be provided with mechanical protection.
- e) Equipment and their auxiliaries are to be arranged and designed to satisfy the following criteria:
  - a fire is not to cause the loss of generators of two redundancy zones,
  - a fire is not to cause the loss of main switchboard's sections belonging to two redundancy zones,
  - a fire is not to cause the loss of main equipment of two redundancy zones,
  - a fire is not to cause the loss of propulsion thrusters fed by healthy zones.
- f) Each switchboard serving a different redundancy group is to be located in individual compartments separated by at least A-0 bulkheads and be watertight if below the damage waterline.
- g) Watertight bulkhead separation is to be in place below the damage waterline for machinery spaces.
- h) Each redundancy group is to have its own service tanks and it is to be located in individual compartments separated by A-60 bulkheads and be watertight if below the damage waterline.
- i) Thrusters are to be located in separate watertight compartments with at least A-0 boundaries.

#### 11.4.3 (1/1/2021)

For ships having **DP3** class notation, the following conditions are to be met:

- a) Physical segregation is to be provided between any DP zones.
  - DP zone means a redundancy group that contribute to mitigate the worst-case failure in case of fire event.
  - Both the main equipment and boundaries that constitute each redundancy group are to be defined



based on degradation conditions resulted by the FMEA document.

- b) A-60 separation is to be provided between each DP zone.
- c) Each DP zone is to be autonomous in terms of auxiliary systems.
- d) Auxiliaries not installed near the main equipment may be accepted provided that they are installed within the same DP zone.
- e) Each DP zone may be constituted by two or more compartments. Compartments may be not contiguous or within the same A-60 boundaries.
- f) Cables or pipes cross-connection between different DP zone is not allowed, unless connections between the compartments of the same DP zones are needed for their operation.
- g) Cables or pipe passages between compartments of different DP zones are to be provided of cable ducts of A-60 class.
- h) Cables or pipe passages between compartments of the same DP zones through a common zone are to be provided of mechanical protection.
- i) Common zones crossed by cables of different DP zones are to be protected by ducts A-60 class.
- j) Equipment and their auxiliaries are to be arranged and designed to satisfy the following criteria:
  - a fire is not to cause the loss of generators of two DP zones,
  - a fire is not to cause the loss of main switchboard's sections belong to two DP zones,
  - a fire is not to cause the loss of propulsion thrusters fed by healthy zones,
  - in no case a fire event is to exceed the worst-case failure defined defined for a ship having the **DYNA-POS** notation.
- k) Watertight bulkhead separation is to be in place below the damage waterline for machinery spaces.
- l) Each DP zone is to have its own service tanks and it is to be located in individual compartments separated by A-60 partitions and be watertight if below the damage waterline.
- m) Each switchboard serving a different DP zone is to be located in individual compartments separated by at least A-0 partitions and be watertight if below the damage waterline.
- n) Thrusters are to be located in separate watertight compartments with at least A-0 boundaries.

## 11.5 Functional requirements for PRD notation

### 11.5.1 (1/1/2021)

The notation **PRD** can be added to the **DYNAPOS DP2** and **DP3** notations on a case-by-case basis.

### 11.5.2 (1/1/2021)

For closed bus mode or island mode operation the following conditions are to be met:

- a) The main switchboard is to be divisible in four or more sections, able to operate in different configurations. Different sections configurations will be evaluated on the case by case basis, provide that it is demonstrated the fail-safe equivalence to the above requirements.
- b) Each section of the main switchboard is to be defined as a redundancy feeding section on the basis of the failure conditions considered in the FMEA document.
- c) Based on the design of the main switchboard and relevant control system the redundancy feeding zones may be operated mainly in three modes:
  - Island mode. The redundancy feeding sections are disconnected from each other and operate independently.
  - Open bus-tie mode. The redundancy feeding zones are coupled to form two sections separated of the main switchboard equally distributed.
  - Closed bus-tie mode. The redundancy feeding sections are closed together as a single bus.
- d) Closed bus tie mode may include also the closed loop mode. This last mode refers to redundancy feeding Zones that may be closed in loop configuration directly by the bus-tie breakers or by section-link. To such purpose section-link means part of busbar between two continuous breakers without derived circuits.
- e) Each redundancy feeding section is to be autonomous in term of its auxiliaries, control and automation.
- f) Common cause failure is to be avoided. Where unavoidable it is to be demonstrated the fail-to-safe principle of the system.
- g) Arrangement of the redundancy feeding sections is to satisfy the criteria of DP class assigned and the notation **FFP** if assigned.
- h) The design of the main switchboard control system (and automation) is to be such that a single failure does not exceed the worst-case failure defined for a ship having the **DYNAPOS** notation.
- i) Each section of the main switchboard is to be provided of an approved bus-tie breaker on each end side, able to be operated manually and remotely.
- j) Bus-tie breakers are to be arranged such that a failure of one bus-tie breaker does not result in a total blackout.
- k) The arrangement of bus-tie breakers is to be in compliance with the criteria of **DP** class assigned and the notation **FFP** if assigned.
- l) This safety and alarm system is to be able to activate a software based safety and alarm systems are to satisfy the visual and audible alarm in a manned control sta-

tion and activate safety functions on the switchboard to isolate the faulty section.

- m) This system is to be manually excludable and self-checking type, any abnormal condition is to activate a visual and audible alarm.
- n) Any abnormal condition or failure to the safety and alarm system is not to cause unsafe conditions of the main switchboard.

**11.5.3 (1/1/2021)**

Safety and alarm systems developed on software base are to satisfy the requirements listed in Pt C, Ch 3, Sec 3.

**11.5.4 (1/1/2021)**

Hardware devices needed for operation of the system are to be Type Approved.

**11.5.5 (1/1/2021)**

The network communication system is to be designed to eliminate any hidden failure. The fail to safe condition is to be verified at least in case of: open circuit, short-circuit, power failure, data storm, bus error, timing error, data inconsistency.

**11.5.6 (1/1/2021)**

Any fault in one section of the main switchboard is not to propagate to other sections.

**11.5.7 (1/1/2021)**

Any fault of the safety and alarm system is not to prevent the operation of the main switchboard in open bus-tie mode and island mode.

**11.5.8 (1/1/2021)**

Any fault of the safety and alarm system is not to prevent the local and manual operation of the main switchboard.

**11.5.9 (1/1/2021)**

A fail-to-safe condition is to be defined for each operating mode and documented through the FMEA analysis. The fail to safe conditions is to be demonstrated by the Tasneef Surveyor.

**11.5.10 (1/1/2021)**

Main switchboard and its auxiliaries are to be arranged and designed not to exceed the worst-case failure defined for a ship having the **DYNAPOS** notation.

**11.5.11 (1/1/2021)**

Main switchboard and its auxiliaries are to be suitably arranged to satisfy the criteria of advanced fire and flooding notation if assigned.

**11.5.12 (1/1/2021)**

The ship is to be capable to maintain the position and/or heading in intact conditions with a redundancy feeding section faulty or fault of an associated generators and thrusters. Reliability of each redundancy feeding section and segregation of each DP zone is to be demonstrated on board.

**11.5.13 (1/1/2023)**

For standby system of generators, the following conditions are to be met:

- a) Each diesel generator is to be provided of a safety and alarm system (here after called Advanced Generator

System, AGS) capable to detect abnormal conditions during the operation of each generator.

- b) The Advanced Generator System is to be capable to detect and alarm at least the following anomalies included but not limited to:
  - Excess and insufficient fuel
  - Over and under-excitation
  - Generator instability or hunting
  - Loss of exciter current
  - Active and reactive power sharing imbalance
- c) The AGS is to be able to activate a visual and audible alarm in a manned control station and activate safety functions (stopping and/or disconnecting) the respective diesel generator.
- d) This system is to be manually excludable and self-checking type, any abnormal condition is to activate a visual and audible alarm.
- e) Any abnormal condition or failure to the safety and alarm system is not to cause unsafe conditions of the generator.
- f) Any fault to the AGS is not to stop any running generator and prevent the operation of generators in stand-by.
- g) Any fault of the safety and alarm system is not to prevent the local and manual operation of the diesel generator.
- h) A fail-to-safe condition is to be defined and documented through the FMEA analysis. The fail to safe conditions is to be demonstrated by Tasneef Surveyor.
- i) Main switchboard and its auxiliaries are to be arranged and designed to not exceed the worst case failure defined for a ship having the **DYNAPOS** notation.
- j) Main switchboard and its auxiliaries are to be suitably arranged to satisfy the criteria of advanced fire and flooding notation if assigned.
- k) Auxiliary equipment needs for the starting and operation of the diesel generator are to be duplicated and suitably arranged to satisfy the criteria of advanced fire and flooding notation if assigned.
- l) Auxiliary equipment mechanically driven not need to be duplicated.
- m) Hydraulic-mechanical type governor does not need to be duplicated.
- n) All active components necessary to manage the auxiliaries of each redundancy feeding section are to be Type Approved.
- o) The standby generator is to be able to start and supply power within 45 seconds.
- p) Single automatic voltage regulator may be accepted if provided of two mirrored control systems (master and slave type).
- q) Duplicated auxiliary equipment are to be provided of self-checking system as appropriate. Any abnormal condition is to be alarmed and activate the automatic change-over with the standby equipment.
- r) Auxiliary equipment may be dedicated to group of diesel generator (e.g. sea water cooling system) based on

the criteria of advanced fire and flooding notation if assigned.

- s) In no case the grouping of auxiliary equipment is to exceed the worst case failure defined for a ship having the **DYNAPOS** notation in case of single failure.
- t) A system capable to prevention a blackout condition is to be provided. This system is to include:
  - dynamic limiting of electrical power of the propulsion system according to available power,
  - response time quick enough to avoid damage to the generators.
- u) Where the risk of total blackout cannot be eliminated, a detailed blackout resolution procedure/sequence has to be submitted for acceptance. The blackout scenarios are to be defined and documented through the FMEA analysis. Blackout procedure and sequence are to be demonstrated onboard to satisfaction of **Tasneef Surveyor**.
- v) The power management system is to be able to re-establish the functioning of the power plant automatically, without any human intervention, within 60 seconds after blackout, generators and thrusters for DP are also to be available within 60 seconds
- w) The time of 60 seconds is to be noted and considered during the development of the Risk Assessment for each operating procedure.

#### **11.5.14 (1/1/2021)**

Software based safety and alarm systems are to satisfy the requirements listed to Pt C, Ch 3, Sec 3.

#### **11.5.15 (1/1/2021)**

Hardware devices needs for operation of the system are to be Type Approved.

#### **11.5.16 (1/1/2021)**

In any case the acceptability is to be verified on case by case basis taking into account the operating profile of the vessel.

### **11.6 FMEA proving trials**

#### **11.6.1 (1/1/2021)**

For each **DP PLUS** notation assigned to **DP2** and **DP3** class ship, proving trials in order to check the results of FMEA tests are to be carried out to the satisfaction of the attending Surveyor. The test procedures are to simulate realistic failures, as far as practicable. After completion of the DP proving trials, the FMEA proving trial report is to be kept on board.

#### **11.6.2 (1/1/2021)**

For **DP2-DFS** and **DP3-DFS** notations, a dedicated FMEA is to be provided including:

- a) Failure of short-circuit protection systems.
- b) Severe voltage dips associated with short circuit faults in the power plant with the dual feed connection.
- c) Fuel system failures.
- d) Electrical failures of generators, e.g. over and under-excitation, governor and AVR failure modes, etc. and failure modes related to start-up and change-over of standby equipment.
- e) Power management failures.
- f) Blackout and recovery from blackout.
- g) If any, load optimization system.

Test procedures, based on simulation of failures under conditions as realistic as practicable, are to be included in the DP trials manual.

## SECTION 7

## VAPOUR CONTROL SYSTEM (VCS)

### 1 General

#### 1.1 Application

**1.1.1** The additional class notation **VCS** is assigned, in accordance with Pt A, Ch 1, Sec 2, [6.14.7], to ships fitted with systems for control of vapour emission from cargo tanks both in way of midship cargo crossovers and in way of stern cargo manifolds, complying with the requirements of this Section.

The notation **MIDSHIP** is added to the notation **VCS** where the ship is equipped with cargo vapour control systems only in way of cargo midship crossovers.

The notation **TRANSFER** is added to the notation **VCS** for ships fitted with systems for control of vapour emission from cargo tanks to another ship and viceversa. Additional requirements for **TRANSFER** additional notation are given in article [6].

**1.1.2** As a rule, this notation is applicable to ships which are assigned one or more of the following class notations:

- oil tanker
- chemical tanker
- FLS tanker
- liquefied gas carrier
- combination carrier/OOC
- combination carrier/OBO

#### 1.2 Definitions

##### 1.2.1 Diluted

A flammable gas or mixture is defined diluted when its concentration in air is less than 50% of its lower explosive limit.

##### 1.2.2 Flammable cargoes

Flammable cargoes are crude oils, petroleum products and chemicals having a flashpoint not exceeding 60 °C (closed cup tests) and other substances having equivalent fire risk.

##### 1.2.3 Inerted

Inerted is the condition in which the oxygen content in a flammable gas/air mixture is 8% or less by volume.

##### 1.2.4 Independent

Two electrical systems are considered independent when anyone system may continue to operate with a failure of any part of the other system, except power source and electrical feeder panels.

##### 1.2.5 Lightering operation

Lighting operation is the operation of transferring liquid cargo from one ship to one service ship.

##### 1.2.6 Maximum allowable transfer rate

Maximum allowable transfer rate is the maximum volumetric rate at which a ship may receive cargo or ballast.

##### 1.2.7 Service ship

Service ship is a ship which receives and transports liquid cargoes between a facility and another ship and viceversa.

##### 1.2.8 Ship vapour connection

The ship vapour connection is the point of interface between the ship's fixed vapour collection system and the collection system of a facility or another ship. Hoses or loading arms on board, carried for the purpose of these rules, are considered part of the vapour control system of the ship.

##### 1.2.9 Terminal vapour connection

The terminal vapour connection is that point at which the terminal vapour collection system is connected to a vapour collection hose or arm.

##### 1.2.10 Topping-off operation

Topping-off is the operation of transfer of liquid cargo from a service ship to another ship in order to load the receiving ship at a deeper draft.

##### 1.2.11 Vapour balancing

Vapour balancing is the transfer of vapour displaced by incoming cargo from the tank of a ship receiving cargo into a tank of a facility delivering cargo via a vapour collection system.

##### 1.2.12 Vapour collection system

The vapour collection system is an arrangement of piping and hoses used to collect vapour emitted from a ship's cargo tank and to transport the vapour to a vapour processing unit.

##### 1.2.13 Vapour processing unit

Vapour processing unit is that component of a vapour control system that recovers, destroys or disperses vapour collected from a ship.

### 1.3 Documentation to be submitted

**1.3.1** Tab 1 lists the documents which are to be submitted.

Table 1

No.	A/I (1)	Document
1	A	Diagrammatic plan of the vapour piping system including: <ul style="list-style-type: none"> <li>• material specifications</li> <li>• dimensions, scantlings and sizes</li> <li>• ratings (temperature / pressure)</li> <li>• joining details</li> <li>• fittings and standards used</li> <li>• etc.</li> </ul>
2	A	Diagrammatic drawing of the gauging system and overfill protection including: <ul style="list-style-type: none"> <li>• manufacturer and type of the instruments</li> <li>• plan of hazardous area locations</li> <li>• location of electrical equipment in gas dangerous spaces and safe certificates of the electric instruments intended to be used in hazardous locations</li> <li>• electrical schemes concerning the alarm system supply</li> <li>• electrical schemes concerning the intrinsically safe circuits</li> <li>• etc.</li> </ul>
3	A	Diagrammatic drawings of the venting system, including necessary data for verifying the venting capacity of the pressure/vacuum valves
4	I	Pressure drop calculations comparing cargo transfer rates versus pressure drops from the farthest tanks to the vapour connection, included any possible hoses
5	I	Calculations showing the time available between alarm setting and overfill at maximum loading rate for each tank
6	A	Instruction manual
7	I	Information on the antidetonation devices, including manufacturer and type of the device employed as well as documentation on any acceptance test carried out, only for ships for which the notation <b>TRANSFER</b> is requested
(1) A = to be submitted for approval in quadruplicate I = to be submitted for information in duplicate		

## 2 Vapour system

### 2.1 General

#### 2.1.1 Installation of vapour collection system

- Each ship is to have vapour collection piping permanently installed, with the tanker vapour connection located as close as practical to the loading manifolds.
- In lieu of permanent piping, chemical tankers may have vapour connections located in the vicinity of each cargo tanks, in order to preserve segregation of the cargo systems.

#### 2.1.2 Incompatible cargoes

If a tanker simultaneously collects vapour from incompatible cargoes, it is to keep these incompatible vapours separate throughout the entire vapour collection system.

#### 2.1.3 Liquid condensate disposal

Means are to be provided to eliminate liquid condensate which may collect in the system.

#### 2.1.4 Electrical bonding

Vapour collection piping is to be electrically bonded to the hull and is to be electrically continuous.

#### 2.1.5 Inert gas supply isolation

When inert gas distribution piping is used for vapour collection piping, means to isolate the inert gas supply from the vapour collection system are to be provided. The inert gas main isolating valve required in Part C, Chapter 4 may be used to satisfy this requirement.

#### 2.1.6 Prevention of interference between vapour collection and inert gas systems

The vapour collection system is not to interfere with the proper operation of the cargo tank venting system. However, a vapour collection piping may be partly common with the vent piping and/or the inert gas system piping.

#### 2.1.7 Flanges

- Bolt hole arrangement of vapour connection flanges to the terminal is to be in accordance with Tab 2.
- Each vapour connection flange is to have permanently attached 12,7 mm diameter studs protruding out of the flange face for at least 25,4 mm.
- The studs are to be located at the top of the flange, midway between bolt holes and in line with bolt hole patterns.

**Table 2 : Bolting arrangement of connecting flanges**

Pipe nominal diameter (mm)	Outside diameter of flange (mm)	Bolt circle diameter (mm)	Bolt holes diameter (mm)	Bolt diameter (mm)	Number of bolts
≤ 12.70	88.90	60.45	15.75	12.70	4
≤19.05	98.55	69.85	15.75	12.70	4
≤25.40	107.95	79.25	15.75	12.70	4
≤31.75	117.35	88.90	15.75	12.70	4
≤38.10	127.00	98.55	15.75	12.70	4
≤50.80	152.40	120.65	19.05	15.87	4
≤63.50	177.80	139.70	19.05	15.87	4
≤76.20	190.50	152.40	19.05	15.87	4
≤88.90	215.90	177.80	19.05	15.87	8
≤101.60	228.60	190.50	19.05	15.87	8
≤127.00	254.00	215.90	22.35	19.05	8
≤152.40	279.40	241.30	22.35	19.05	8
≤203.20	342.90	298.45	22.35	19.05	8
≤254.00	406.40	361.95	25.40	22.22	12
≤304.80	482.60	431.80	25.40	22.22	12
≤355.60	533.40	476.25	28.45	25.40	12
≤406.40	596.90	539.75	28.45	25.40	16
≤457.20	635.00	577.85	31.75	28.54	16
≤508.00	698.50	635.00	31.75	28.57	20
≤609.60	749.3	749.30	35.05	31.75	20

## 2.2 Vapour manifold

### 2.2.1 Isolation valve

- An isolation valve capable of manual operation is to be provided at the ship vapour connection.
- The valve is to have an indicator to show clearly whether the valve is in the open or closed position, unless the valve position can be readily determined from the valve handle or valve stem.

### 2.2.2 Labelling

The vapour manifold is to be:

- for the last 1 m painted red/yellow/red, with the red bands 0,1 m wide and the yellow band 0,8 m wide;
- labelled "VAPOUR" in black letters at least 50 mm high.

## 2.3 Vapour hoses

### 2.3.1 Hoses

Each hose used for transferring vapour is to have:

- a design burst pressure of at least 0,175 MPa;
- a maximum working pressure of at least 0,035 MPa;
- the capability of withstanding at least 0,014 MPa vacuum without collapsing or constricting;
- electrical continuity with a maximum resistance of 10000 Ω;

- resistance to abrasion and kinking;
- the last 1 m of each end of the hose marked in accordance with [2.2.2];
- for hose flanges see [2.1.7].

### 2.3.2 Handling equipment

Vapour hose handling equipment are to be provided with hose saddles which provide adequate support to prevent kinking or collapse of hoses.

## 2.4 Vapour overpressure and vacuum protection

### 2.4.1 General

The cargo tank venting system is:

- to be capable of discharging cargo vapour at 1.25 times the maximum transfer rate in such a way that the pressure in the vapour space of each tank connected to the vapour collection system does not exceed:
  - the maximum working pressure of the tank;
  - the operating pressure of a safety valve or rupture disk, if fitted;
- not to relieve at a pressure corresponding to a pressure in the cargo tank vapour space of less than 0,007 MPa;

- c) to prevent a vacuum in the cargo tank vapour space, that exceeds the maximum design vacuum for any tank which is connected to the vapour collecting system, when the tank is discharged at the maximum rate;
- d) not to relieve at a vacuum corresponding to a vacuum in the cargo tank vapour space less than 0,0035 MPa below the atmospheric pressure.

#### 2.4.2 Pressure/vacuum safety valves

- a) Pressure/vacuum safety valves are to be fitted with means to check that the device operates freely and does not remain in the open position.
- b) Pressure relief valves are to be fitted with a flame screen at their outlets, unless the valves are designed in such a way as to ensure a vapour discharge velocity of not less than 30 m/second.

## 3 Instrumentation

### 3.1 Cargo tank gauging equipment

**3.1.1** Each cargo tank that is connected to a vapour collection system is to be equipped with a cargo gauging device which:

- provides a closed gauging arrangement which does not require opening the tank to the atmosphere during cargo transfer;
- allows the operator to determine the liquid level in the tank for the full range of liquid levels in the tank;
- indicates the liquid level in the tank, at the location where cargo transfer is located;
- if portable, is installed on tank during the entire transfer operation.

### 3.2 Cargo tank high level alarms

#### 3.2.1 General

- a) Each cargo tank that is connected to a vapour collection system is to be equipped with an intrinsically safe high level alarm system which alarms before the tank overflow alarm, but not lower than 95% of the tank capacity.
- b) The high level alarm is to be identified with the legend "HIGH LEVEL ALARM" and have audible and visible alarm indications that can be seen and heard where the cargo transfer is controlled.

#### 3.2.2 Alarm characteristics

The high level alarm is:

- to be independent of the overflow alarm;
- to alarm in the event of loss of power to the alarm system or failure of the electrical circuits to the tank level sensors.
- to be able to be checked at the tank for proper operation prior to each transfer or contain an electronic self-testing feature which monitors the condition of the alarm circuits and sensors.

### 3.3 Cargo tank overflow alarms

#### 3.3.1 General

- a) Each cargo tank that is connected to a vapour collection system is to be equipped with an intrinsically safe overflow alarm which alarms early enough to allow the person in charge of transfer operation to stop the transfer operation before the cargo tank overflows.
- b) The overflow alarm is to be identified with the legend "OVERFILL ALARM" and have audible and visible alarm indications that can be seen and heard where the cargo transfer is controlled and in the deck cargo area.

#### 3.3.2 Alarm characteristics

The overflow alarm is:

- to be independent of both the high level alarm (see [3.2.1]) and the cargo gauging system (see [3.1]);
- to alarm in the event of loss of power to the alarm system or failure of the electrical circuits to the tank level sensors.
- to be able to be checked at the tank for proper operation prior to each transfer or contain an electronic self-testing feature which monitors the condition of the alarm circuits and sensors.

### 3.4 High and low vapour pressure alarms

#### 3.4.1 Pressure alarms

Each vapour collection system is to be fitted with one or more pressure sensing devices that sense the pressure in the main collection line, which:

- have a pressure indicator located where the cargo transfer is controlled;
- alarm the high pressure of not more than 90% of the lowest relief valve setting in the tank venting system;
- alarm at a low pressure of not less than 0,98 kPa for an inerted tank, or the lowest vacuum relief valve setting in the cargo venting system for a non-inerted tank.

#### 3.4.2 Equivalence

Pressure sensors fitted in each cargo tank are acceptable as equivalent to pressure sensors fitted in each main vapour collection line.

## 4 Instruction manual

### 4.1 General

#### 4.1.1

- a) Each ship utilising a vapour emission control system is to be provided with written operational instructions covering the specific system installed on the ship.
- b) Instructions are to encompass the purpose and principles of operation of the vapour emission control system and provide an understanding of the equipment involved and associated hazards. In addition, the instructions are to provide an understanding of the operating procedures, piping connection sequence, start-up procedures, normal operations and emergency procedures.

## 4.2 Content

### 4.2.1 The instruction are to contain:

- a) a line diagram of the tanker's vapour collection piping including the location of each valve, control device, pressure-vacuum safety valve, pressure indicator, flame arresters and detonation arresters, if fitted;
- b) the maximum allowable transfer rate for each group of cargo tanks having the same venting line, determined as the lowest of the following:
  - 1) 80% of the total venting capacity of the pressure relief valves in the cargo tank venting systems;
  - 2) the total vacuum relieving capacity of the vacuum relief valves in the cargo tank venting system;
  - 3) the rate based on pressure drop calculations at which, for a given pressure at the facility vapour connection, or, if lightering, at the vapour connection of the service ship, the pressure in any cargo tank connected to the vapour collection system exceeds 80% of the setting of any pressure relief valve in the cargo tank venting system;
- c) the initial loading rate for each cargo tank, to be determined in such a way as to minimise the development of a static electrical charge, when applicable;
- d) tables or graphs of transfer rates and corresponding vapour collection system pressure drops including the vapour hoses, if foreseen) determined, from the most remote cargo tanks to the ship vapour connection, as follow:
  - 1) for each cargo handled by the vapour collection system at the a maximum transfer rate and at the lesser transfer rates;
  - 2) based on 50% cargo vapour and air mixture, and a vapour growth rate appropriate for the cargo being loaded;
- e) the safety valve setting at each pressure-vacuum safety valve.

## 5 Testing and trials

### 5.1

#### 5.1.1 General

Machinery and equipment which are part of the vapour collecting system are to be tested in compliance with the applicable requirements of the various Sections of the Rules.

#### 5.1.2 Hydrostatic tests

Pressure parts are to be subjected to hydrostatic tests in accordance with the applicable requirements.

#### 5.1.3 Pressure/vacuum valves

Pressure/vacuum valves are to be tested for venting capacity. The test is to be carried out with the flame screen installed if contemplated in accordance with [2.4.2].

### 5.2 On board trials

**5.2.1** Upon completion of construction, in addition to conventional sea trials, specific tests may be required at the Society's discretion in relation to the characteristics of the plant fitted on board.

## 6 Additional requirements for "TRANSFER" notation

### 6.1 Application

**6.1.1** These requirements are applicable to service ships.

### 6.2 Equipment

#### 6.2.1 Ships with inerted cargo tanks

If the cargo tanks on a ship discharging cargo and a ship receiving cargo are inerted, the service ship is to have means to inert the vapour transfer hose prior to transferring cargo vapour and an oxygen analyser with a sensor or sampling connection fitted within 3 m of the ship vapour connection which:

- activates an audible and visible alarm at a location on the service ship where cargo transfer is controlled when the oxygen content in the vapour collection system exceeds 8% by volume;
- has an oxygen concentration indicator located on the service ship where the cargo transfer is controlled;
- has a connection for injecting a span gas of known concentration for calibration and testing of the oxygen analyser.

#### 6.2.2 Ships with cargo tanks not inerted

If the cargo tanks on a ship discharging cargo are not inerted, the vapour collection line on the service ship is to be fitted with a detonation arrester located within 3 m of the ship vapour connection.

#### 6.2.3 Electrical insulating flange

An electrical insulating flange or one length of non-electrically conductive hose is to be provided between the vapour connection of the service ship and the vapour connection on the ship being lightered.



## SECTION 8

## COFFERDAM VENTILATION (COVENT)

### 1 General

#### 1.1 Application

##### 1.1.1 (1/7/2004)

The additional class notation **COVENT** is assigned, in accordance with Pt A, Ch 1, Sec 2, [6.14.8], to ships having all cofferdams (including ballast tanks) in cargo area which are provided with fixed ventilation systems or having movable components included in the ship equipment complying with the requirements of this Section.

**1.1.2** For the purpose of this Section cargo area is that portion of the ship included between the forward bulkhead of the machinery space and the collision bulkhead.

In the case of ships with machinery spaces located amidships, the cargo area is also to include that portion of the ship between the aft bulkhead of the engine space and the after peak bulkhead, excluding the shafting tunnel.

#### 1.2 Documents to be submitted

**1.2.1** The documents listed in Tab 1 are to be sent to Society for approval.

The Society reserves the right to require additional plans or information in relation to the specific characteristics of the installations.

### 2 Design and construction

#### 2.1 Arrangement

##### 2.1.1 Number of air changes

a) The ventilation system is to be capable to supply at least 4 complete air changes per hours, based on the cofferdam gross volume.

b) For cofferdams adjacent to spaces where dangerous mixtures may be present, such as, for instance cargo tanks of oil carriers, chemical carriers and gas carriers, the minimum number of air changes per hour is to be increased to 8.

##### 2.1.2 Avoidance of stagnation zones (1/7/2004)

In order to avoid air stagnation zones, air exhaust ports inside the cofferdam are to be adequately distributed.

Particular attention is to be paid to the arrangement of the inlet and outlet ducts in the cofferdams surrounding the cargo tanks of the double hull tankers, where, due to the particular shape of the cofferdams and the presence of stiffening inside it is easy the formation of stagnant zones.

##### 2.1.3 Cofferdams that may be used as ballast tanks

Provisions are to be taken to blank the inlet and outlet ventilation ducts, when the cofferdams are used for carriage of ballast.

#### 2.2 Other technical requirements

##### 2.2.1 Ventilation inlets and outlets (1/7/2002)

Ventilation inlets and outlets leading to the open air from cofferdam adjacent to dangerous spaces are to be fitted with protective screens recognized as suitable by the Society. The spacing between them and from ignition sources, openings into spaces where ignition sources are present, openings into cargo tanks and air inlets and outlets of different spaces is to be not less than 3m.

##### 2.2.2 Fans (1/7/2002)

a) Ventilation fans are to be of non-sparking construction in accordance with the requirements of Part C, Chapter 4.

b) In the case the ventilated cofferdams are adjacent to a dangerous space, the electric motors driving the ventilation fans are not to be located in the ventilation ducts.

**Table 1**

No.	A/I (1)	Item
1	I	Schematic drawing of the installations
2	A	Calculation of number of air changes per hour for each cofferdam in cargo area
3	A	Line diagram of power supply circuits of control and monitoring systems, including circuit table
4	A	List and type of equipment and in particular type of fans and their arrangements in ducts
5	I	Plan of the location and arrangements of the control station, if any
6	A	List of remote control devices, if any
7	A	List of alarms
<p>(1) A = to be submitted for approval in quadruplicate I = to be submitted for information in duplicate</p>		

### **2.2.3 Lighting**

In the case the cofferdams are provided with electric light appliances, the ventilation system is to be interlocked with the lighting, such that ventilation is to be in operation to energise the lighting.

### **2.2.4 Alarms**

An audible and visible alarm is to be activated in case of failure of the ventilation.

### **2.2.5 Additional requirements**

For chemical tankers and gas carriers the requirements in Pt E, Ch 8, Sec 12 and Pt E, Ch 9, Sec 12 respectively are also to be applied.

## **3 Inspections and testings**

### **3.1 Equipment and systems**

**3.1.1** Equipment and systems are to be inspected and tested in accordance with the applicable requirements of the Rules relative at each piece of equipment or system used for the ventilation of the cofferdams.

### **3.2 Testing on board**

**3.2.1** Following installation on board, the ventilation systems are to be subjected to operational tests in the presence of the Surveyor.

## SECTION 9

# CENTRALISED CARGO AND BALLAST WATER HANDLING INSTALLATIONS (CARGOCONTROL)

### 1 General

#### 1.1 Application

**1.1.1** The additional class notation **CARGOCONTROL** is assigned, in accordance with Pt A, Ch 1, Sec 2, [6.14.9], to ships carrying liquid cargo in bulk fitted with a centralised system for handling cargo and ballast liquids and complying with the requirements of this Section.

**1.1.2** Compliance with these Rules does not exempt the Owner from the obligation of fulfilling any additional requirements issued by the Administration of the State whose flag the ship is entitled to fly.

#### 1.2 Documents to be submitted

**1.2.1** The documents listed in Tab 1 are to be sent to Society for approval.

The Society reserves the right to require additional plans or information in relation to the specific characteristics of the installations.

### 2 Design and construction requirements

#### 2.1 Control station

##### 2.1.1 Location of control station

- a) The control station is to be located such as to allow visibility of the cargo tanks deck area, and in particular of the cargo loading and unloading ramps.
- b) The station is preferably to be situated in the accommodation area; should this be impracticable, the control

station is to be bounded by A-60 Class fire-resisting bulkheads and provided with two escapes.

##### 2.1.2 Communications

It is possible from the control station to convey orders to crew members on deck and to communicate with the navigating bridge, with cargo handling spaces, with the engine room and with the propulsion control room, where the latter is foreseen.

##### 2.1.3 Safety equipment

Where the control station is located in the cargo area, two complete sets of protective clothing in order to protect the skin from the heat radiating from the fire are always to be readily available together with three breathing apparatuses.

#### 2.2 Remote control, indication and alarm systems

##### 2.2.1 Remote control system

It is to be possible to carry out the following operations from the control station

- a) opening and closing of valves normally required to be operated for loading, unloading and transfer of cargo and ballast (however, the opening and closing of valves is not required for the ends of cargo loading and unloading arrangements);
- b) starting and stopping of cargo pumps, stripping pumps and ballast pumps (alternative solutions may be considered in the case of pumps powered by turbines);
- c) regulation, if foreseen, of the number of revolutions of cargo pumps, stripping pumps and ballast pumps.

**Table 1**

No.	A/I (1)	Item
1	I	Schematic drawing of the installations
2	I	Plan of the location and arrangements of the control station
3	A	List of remote control devices
4	A	List of alarms
5	I	List of the equipment (sensors, transducers, etc.) and automation systems (alarm systems, etc.) envisaged with indication of the manufacturer and of the type of equipment or system

No.	A/I (1)	Item
6	A	Line diagram of power supply circuits of control and monitoring systems, including <ul style="list-style-type: none"> <li>• circuit table, in the case of electrical power supply</li> <li>• specification of service pressures, diameter and thickness of piping, materials used, etc. in the case of hydraulic or pneumatic power supply</li> </ul>
(1) A = to be submitted for approval in quadruplicate I = to be submitted for information in duplicate		

### 2.2.2 Indication system

The control station is to be fitted with indicators showing:

- (open/closed) position of valves operated by remote control;
- state (off/on) of cargo pumps, stripping pumps and ballast pumps;
- number of revolutions of cargo pumps, stripping pumps and ballast pumps where they may be operated at adjustable speeds;
- delivery pressure of the hydraulic plant for the operation of cargo pumps, stripping pumps and ballast pumps;
- delivery and suction pressure of cargo pumps, stripping pumps and ballast pumps;
- pressure of the ends of cargo loading and unloading arrangements;
- oxygen level, temperature and pressure of the inert gas, where the operation of the inert gas system is required or envisaged at the same time as loading/unloading;
- level in cargo and ballast tanks (relaxation of this requirement may be permitted for double bottom ballast tanks of reduced capacity and limited depth);
- temperature in cargo tanks provided with heating or refrigeration.

### 2.2.3 Alarm systems

The cargo control station is to be fitted with visual and audible alarms signalling the following:

- high level, and where requested very high level, in cargo tanks;
- high pressure in cargo tanks, if required by the Rules;

- low delivery pressure of the hydraulic plant for the operation of pumps and valves;
- high vacuum in cargo tanks, if required by the Rules;
- high pressure in the cargo and ballast lines;
- high and low temperature for cargo tanks fitted with heating and refrigerating systems;
- high oxygen level, high temperature, high and low pressure of inert gas, if foreseen;
- high level in a bilge well in cargo and ballast pump rooms;
- high concentration of explosive vapours (exceeding 30% of the lower flammable limit) in spaces where cargo is handled;
- high temperature of gas tight seals with oil glands for runs of shafts, where these are foreseen through bulkheads or decks, for the operation of cargo and ballast pumps.

## 3 Inspections and testings

### 3.1 Equipment and systems

**3.1.1** Equipment and systems are to be inspected and tested in accordance with the applicable requirements of the Rules relative to each piece of equipment or system used for the centralised control.

### 3.2 Testing on board

**3.2.1** Following installation on board, remote control, indication and alarm systems are to be subjected to operational tests in the presence of the Surveyor.

## SECTION 10

## SHIP MANOEUVRABILITY (MANOVR)

### 1 General

#### 1.1 Application

**1.1.1** The additional class notation **MANOVR** is assigned, in accordance with Pt A, Ch 1, Sec 2, [6.14.10], to ships whose manoeuvring capability standards are complying with the requirements of this Section.

##### 1.1.2 (1/7/2009)

The requirements of this Section reproduce the provisions of the IMO Resolution MSC 137(76) "Standards for Ship Manoeuvrability" and are applicable to ships of all rudder and propulsion types, of 100 m in length and over, and to chemical tankers and gas carriers regardless of the length, which were constructed on or after 1 July 1994.

Note 1: Reference is also to be made to IMO MSC/Circ. 1053 on Explanatory notes to the Standards for ship manoeuvrability.

#### 1.2 Manoeuvres evaluation

##### 1.2.1 Conventional trials

The requirements in this section are based on the understanding that the manoeuvrability of ships can be evaluated from the characteristics of conventional trial manoeuvres.

##### 1.2.2 Compliance with the requirements

The following two methods can be used to demonstrate compliance with these requirements:

- Scale model tests and/or predictions using computer programs with mathematical model can be performed to predict compliance at the design stage.  
Results of the model test and/or computer simulations will be confirmed by full scale trials, as necessary.
- The compliance with these requirements can be demonstrated based on the results of the full scale trials conducted in accordance with such requirements.

### 2 Definitions

#### 2.1 Geometry of the ship

##### 2.1.1 Length (L)

Length (L) is the length measured between the aft and forward perpendiculars.

##### 2.1.2 Midship point

Midship point is the point on the centreline of a ship midway between the aft and forward perpendiculars.

##### 2.1.3 Draught $T_A$

The draught  $T_A$  is the draught at the aft perpendicular.

##### 2.1.4 Draught $T_F$

The draught  $T_F$  is the draught at the forward perpendicular.

##### 2.1.5 Mean draught $T_M$

The mean draught  $T_M$  is defined as  $T_M = (T_A + T_F)/2$ .

##### 2.1.6 Trim T (1/7/2009)

The trim (T) is defined as  $T = (T_A - T_F)$ .

##### 2.1.7 Displacement $\Delta$ (1/7/2009)

The displacement  $\Delta$  is the full load displacement of the ship (in tonnes).

#### 2.2 Standard manoeuvres and associated terminology

##### 2.2.1 Test speed

The test speed (V) used in the requirements is a speed of at least 90% of the ship's speed corresponding to 85% of the maximum engine output.

##### 2.2.2 Turning circle manoeuvre

The turning circle manoeuvre is the manoeuvre to be performed to both starboard and port with 35° rudder angle or the maximum rudder angle permissible at the test speed, following a steady approach with zero yaw rate.

##### 2.2.3 Advance

Advance is the distance travelled in the direction of the original course by the midship point of a ship from the position at which the rudder order is given to the position at which the heading has changed 90° from the original course.

##### 2.2.4 Tactical diameter

Tactical diameter is the distance travelled by the midship point of a ship from the position at which the rudder order is given to the position at which the heading has changed 180° from the original course. It is measured in a direction perpendicular to the original heading of the ship.

##### 2.2.5 Zig-zag test

Zig-zag test is the manoeuvre where a known amount of helm is applied alternately to either side when a known heading deviation from the original heading is reached.

##### 2.2.6 10°/10° zig-zag test

10°/10° zig-zag test is performed by turning the rudder alternately by 10° either side following a heading deviation of 10° from the original heading accordance with the following procedure.

- after a steady approach with zero yaw rate, the rudder is put over 10° to starboard/port (first execute);
- when the heading has changed to 10° off the original heading, the rudder is reversed to 10° to port/starboard (second execute);

- c) after the rudder has been turned to port/starboard, the ship will continue turning in the original direction with decreasing turning rate. In response to the rudder, the ship is then to turn to port/starboard. When the ship has reached a heading of 10° to port/starboard of the original course, the rudder is again reversed to 10° to starboard/port (third execute).

### 2.2.7 First overshoot angle

The first overshoot angle is the additional heading deviation experienced in the zig-zag test following the second execute.

### 2.2.8 Second overshoot angle

The second overshoot angle is the additional heading deviation experienced in the zig-zag test following the third execute.

### 2.2.9 20°/20° zig-zag test

20°/20° zig-zag test is performed using the same procedure given in [2.2.6] above using 20° rudder angle and 20° change of heading, instead of 10° rudder angles and 10° change of heading, respectively.

### 2.2.10 Full astern stopping test

Full astern stopping test determines the track reach of ship from the time an order for full astern is given until the ship stops in water.

### 2.2.11 Track reach

Track reach is the distance along the path described by the midship point of a ship measured from the position at which an order for full astern is given to the position at which the ship stops in the water.

## 3 Requirements

### 3.1 Foreword

3.1.1 The standard manoeuvres are to be performed without the use of any manoeuvring aids, which are not continuously and readily available in normal operations.

### 3.2 Conditions at which the requirements apply

#### 3.2.1 (1/7/2009)

In order to evaluate the performance of a ship, manoeuvring trials are to be conducted to both port and starboard and at conditions specified below:

- deep, unrestricted water
- calm environment
- full load (summer load line draught), even keel condition
- steady approach at test speed.

## 3.3 Criteria for manoeuvrability evaluation

### 3.3.1 Turning ability

The advance is not to exceed 4,5 ship lengths (L) and the tactical diameter is not to exceed 5 ship lengths in the turning circle manoeuvre.

### 3.3.2 Initial turning ability

With the application of 10° rudder angle to port/starboard, the ship is not to have travelled more than 2,5 ship lengths by the time the heading has changed by 10° from the original heading.

### 3.3.3 Yaw checking and course keeping ability (1/7/2009)

- The value of the first overshoot angle in the 10° zig-zag test is not to exceed:
  - 10°, if L/V is less than 10 seconds;
  - 20°, if L/V is 30 seconds or more; and
  - $(5 + 1/2 (L/V))$  degrees, if L/V is 10 seconds or more, but less than 30 seconds.where L and V are expressed in m and m/second respectively.
- The value of the second overshoot angle in the 10°/10° zig-zag test is not to exceed:
  - 25°, if L/V is less than 10 seconds;
  - 40°, if L/V is 30 seconds or more; and
  - $(17,5 + 0,75 (L/V))$  degrees, if L/V is 10 seconds or more, but less than 30 seconds.
- The value of the first overshoot angle in the 20°/20° zig-zag test is not to exceed 25°.

### 3.3.4 Stopping ability (1/7/2009)

The track reach in the full astern stopping test is not to exceed 15 ship lengths. However, this value may be increased after judgement of the Society for large ships, but in no case is it to exceed 20 ship lengths.

### 3.3.5 Non-conventional steering and propulsion systems (1/7/2009)

For ships with non-conventional steering and propulsion systems, the Society may permit the use of comparative steering angles to the rudder angles specified in this Section.

## 4 Additional considerations

### 4.1 Trials in different conditions

4.1.1 In the case where the standard trials are conducted in conditions different from those specified in [3.2.1] c), the corrections deemed necessary, at judgement of the Society, is to be made in each particular instance.

### 4.2 Dynamic instability

4.2.1 Where standard manoeuvres indicate dynamic instability the Society may require additional tests to be conducted to define the degree of instability, such as spiral tests or the pull out manoeuvre.

## SECTION 11

## DAMAGE STABILITY (DMS)

### 1 General

#### 1.1

##### 1.1.1 (1/7/2010)

The additional class notation **DMS** is assigned, in accordance with Pt A, Ch 1, Sec 2, [6], to ships complying with the damage stability requirements given in this Section.

#### 1.2 Documents to be submitted

##### 1.2.1 (1/7/2010)

The stability documentation to be submitted for approval is as follows:

- damage stability calculations,
- damage control documentation.

##### 1.2.2 (1/10/2005)

A copy of the documentation as per [1.2.1] is to be available on board for the attention of the Master.

### 2 Requirements applicable to all type of ships

#### 2.1 Approaches to be followed for damage stability investigation

##### 2.1.1 General (1/7/2014)

Damage stability calculations are required in order to achieve a minimum degree of safety after flooding.

In order to assess the behaviour of the ship after damage, the requirements contained in Chapter II-1 of Solas'74 as amended are to be complied with if not otherwise stated in item [3], depending on the ship type and taking into account the exceptions as per the footnote to Regulation 4 of the above-mentioned Chapter II-1. Ships not subject to Chapter II-1 of Solas'74 as amended will be considered on a case by case basis with the exception of ships indicated in item [4] for which specific requirements are given therein.

##### 2.1.2 Damage stability calculations (1/7/2010)

The damage stability calculations are to include:

- list of the characteristics (volume, centre of gravity, permeability) of each compartment which can be damaged

- a table of openings in bulkheads, decks and side shell reporting all the information about:
  - identification of the opening
  - vertical, transverse and horizontal location
  - type of closure: sliding, hinged or rolling for doors
  - type of tightness: watertight, weathertight, semi-watertight or unprotected
  - operating system: remote control, local operation, indicators on the bridge, television surveillance, water leakage detection, audible alarm, as applicable
  - foreseen utilisation: open at sea, normally closed at sea, kept closed at sea
- list of all damage cases corresponding to the applicable requirements
- detailed results of damage stability calculations for all the loading conditions foreseen in the applicable requirements
- the limiting GM/KG curve, if foreseen in the applicable requirements
- capacity plan
- arrangement of cross-flooding, pipes showing location of remote controls for valves, or special mechanical means to correct list due to flooding, if any
- watertight and weathertight door plan.

As a supplement to the approved damage stability documentation, a loading instrument, approved by the Society, may be used to facilitate the damage stability calculations mentioned in this Section.

The procedure to be followed, as well as the list of technical details to be sent in order to obtain loading instrument approval, are given in Pt B, Ch 11, Sec 2, [4.8].

##### 2.1.3 Damage control documentation (1/7/2010)

The damage control documentation is to include a damage control plan which is intended to provide ship's officers with clear information on the ship's watertight compartments and equipment related to maintaining the boundaries and effectiveness of the watertight compartments so that, in the event of damage causing flooding, proper precautions can be taken to prevent progressive flooding through openings therein and effective action can be taken quickly to mitigate and, where possible, recover the ship's loss of stability.

The damage control documentation is to be clear and easy to understand. It is not to include information which is not directly relevant to damage control, and is to be provided in the language or languages of the ship's officers. If the languages used in the preparation of the documentation are not English or French, a translation into one of these languages is to be included.

The use of a loading instrument performing damage stability calculations may be accepted as a supplement to the damage control documentation. This instrument is to be approved by the Society according to the requirements of Pt B, Ch 11, Sec 2, [4.8].

The damage control plan is required for the following ships:

- Ships carrying passengers
- Dry cargo ships corresponding to:
  - Part E, Chapter 1
  - Part E, Chapter 2
  - Part E, Chapter 3
  - Part E, Chapter 4
  - Part E, Chapter 5
  - Part E, Chapter 6
  - Part E, Chapter 18

Note 1: Dry cargo ship is intended to mean a cargo ship which has not been designed to carry liquid cargo in bulk; furthermore, the following ship types are not to be considered as dry cargo ships:

- tugs, as defined in Part E, Chapter 14
- supply vessels, as defined in Part E, Chapter 15
- fire-fighting ships, as defined in Part E, Chapter 16
- oil recovery ships, as defined in Part E, Chapter 17.

#### 2.1.4 Progressive flooding (1/10/2005)

##### a) Definition

Progressive flooding is the additional flooding of spaces which were not previously assumed to be damaged. Such additional flooding may occur through openings or pipes as indicated in b) and c).

##### b) Openings

The openings may be listed in the following categories, depending on their means of closure:

- Unprotected

Unprotected openings may lead to progressive flooding if they are situated within the range of the positive righting lever curve or if they are located below the waterline after damage (at any stage of flooding). Unprotected openings are openings which are not fitted with at least weathertight means of closure.

- Weathertight

Openings fitted with weathertight means of closure are not able to sustain a constant head of water, but they can be intermittently immersed within the positive range of stability.

Weathertight openings may lead to progressive flooding if they are located below the waterline after damage (at any stage of flooding).

- Semi-watertight

Internal openings fitted with semi-watertight means of closure are able to sustain a constant head of water corresponding to the immersion relevant to the highest waterline after damage at the equilibrium of the intermediate stages of flooding.

Semi-watertight openings may lead to progressive flooding if they are located below the final equilibrium waterline after damage.

- Watertight

Internal openings fitted with watertight means of closure are able to sustain a constant head of water corresponding to the distance between the lowest edge of this opening and the bulkhead/freeboard deck.

Air pipe closing devices complying with Pt C, Ch 1, Sec 10, [9.1.6] may not be considered watertight, unless additional arrangements are fitted in order to demonstrate that such closing devices are effectively watertight.

The pressure/vacuum valves (PV valves) currently installed on tankers do not theoretically provide complete watertightness.

Manhole covers may be considered watertight provided the cover is fitted with bolts located such that the distance between their axes is less than five times the bolt's diameter.

Access hatch covers leading to tanks may be considered watertight.

Watertight openings do not lead to progressive flooding.

##### c) Pipes

Progressive flooding through pipes may occur when:

- the pipes and connected valves are located within the assumed damage, and no valves are fitted outside the damage
- the pipes, even if located outside the damage, satisfy all of the following conditions:
  - the pipe connects a damaged space to one or more spaces located outside the damage,
  - the highest vertical position of the pipe is below the waterline, and
  - no valves are fitted.

The possibility of progressive flooding through ballast piping passing through the assumed extent of damage, where positive action valves are not fitted to the ballast system at the open ends of the pipes in the tanks served, is to be considered. Where remote control systems are fitted to ballast valves and these controls pass through the assumed extent of damage, then the effect of damage to the system is to be considered to ensure that the valves would remain closed in that event.

If pipes, ducts or tunnels are situated within assumed flooded compartments, arrangements are to be made to ensure that progressive flooding cannot thereby extend to compartments other than those assumed flooded. However, the Society may permit minor progressive flooding if it is demonstrated that the additional flooding



of those compartments cannot lead to the capsizing or the sinking of the ship.

Requirements relative to the prevention of progressive flooding are specified in Pt C, Ch 1, Sec 10, [5.5].

### 3 Additional requirements applicable to specific type of ships

#### 3.1 Bulk carriers

##### 3.1.1 General (1/7/2010)

Bulk carriers are to comply with the requirements in [2.1.1].

##### 3.1.2 Additional requirements for single side skin bulk carriers equal to or greater than 150 m in length (1/7/2010)

The requirements specified in Chapter XII of Solas'74 as amended apply.

#### 3.2 Alternative requirements to those given in this Section

##### 3.2.1 (1/7/2010)

Taking into account the ship dimensions, service and navigation, alternative requirements to those given in this Section may be accepted by the Society on a case-by-case basis

### 4 Specific damage stability requirements for ships not subject to the SOLAS Convention

#### 4.1 Passenger ships

##### 4.1.1 General (1/7/2014)

For passenger ships not subject to the SOLAS Convention, the requirements of Chapter II-1 of the European Union Directive 98/18/EC adopted by the Council on 17 March 1998 apply.

#### 4.2 Non-propeller units with the service notation barge - accommodation

##### 4.2.1 General (1/7/2014)

- a) The unit is to have sufficient freeboard and be subdivided by means of watertight decks and bulkheads to provide sufficient buoyancy and stability to withstand in general the flooding of any one compartment in any operating condition consistent with the damage assumptions set out in item [4.2.2].
- b) The unit is to have sufficient reserve stability in a damaged condition to withstand the wind heeling moment based on a wind velocity of 25,8 m/s (50 knots) superimposed from any direction. In this condition, the final waterline, after flooding, is to be below the lower edge of any downflooding opening.
- c) Compliance with the requirements of items a) and b) is to be determined by calculations which take into consideration the proportions and design characteristics of the unit and the arrangements and configuration of the damaged compartments. In making these calculations,

it is to be assumed that the unit is in the worst anticipated service condition as regards stability and is floating free of mooring restraints.

- d) The ability to reduce angles of inclination by pumping out or ballasting compartments or application of mooring forces, etc., is not to be considered as justifying any relaxation of the requirements.
- e) For the purpose of stability calculations, tanks whose vents or overflows terminate on open decks or in locations assumed flooded, or in any event not above the final calculated water line in damaged conditions, are to be considered flooded. Where the tanks are considered flooded, the locations where their vents and/or overflows terminate are also to be assumed flooded.
- f) Alternative subdivision and damage stability criteria may be considered for approval by the Society provided an equivalent level of safety is maintained. In determining the acceptability of such criteria, the Society may consider at least the following and take into account:
  - 1) extent of damage as set out in item [4.2.2];
  - 2) the provision of an adequate margin against capsizing.

##### 4.2.2 Extent of damage (1/7/2014)

- a) In assessing the damage stability, the following extent of damage is to be assumed to occur between effective watertight bulkheads:
  - horizontal penetration: 1,5 m; and
  - vertical extent: from the base line upwards without limit.
- b) The distance between effective watertight bulkheads or their nearest stepped portions which are positioned within the assumed extent of horizontal penetration is to be not less than 3,0 m; where there is a lesser distance, one or more of the adjacent bulkheads is to be disregarded.
- c) Where damage of a lesser extent than in item a) results in a more severe condition, such lesser extent is to be assumed. In addition, the compartments bounded by the bottom shell are to be considered flooded individually.
- d) All piping, ventilation systems, trunks, etc., within the extent of damage referred to in item a) are to be assumed to be damaged. Positive means of closure are to be provided at watertight boundaries to preclude the progressive flooding of other spaces which are intended to be intact.

##### 4.2.3 Watertight integrity (1/7/2014)

- a) General
  - 1) All units are to be provided with watertight bulkheads to provide transverse strength subdivision. In all cases, the plans submitted are to clearly indicate the location and extent of the bulkheads.
  - 2) For compliance with the requirements of damage stability, where individual lines, ducts or piping systems serve more than one compartment or are within the extent of damage, satisfactory arrangements are to be provided to preclude the possibility

of progressive flooding through the system to other spaces, in the event of damage.

- 3) The number of openings in watertight subdivisions is to be kept to a minimum compatible with the design and proper working of the unit. Where penetrations of watertight decks and bulkheads are necessary for access, piping, ventilation, electrical cables, etc., arrangements are to be made to maintain the watertight integrity of the enclosed compartments.
- 4) Where valves are provided at watertight boundaries to maintain watertight integrity, these valves are to be capable of being operated from a weather deck, or a deck which is above the final waterline after flooding.

Valve position indicators are to be provided at the remote control position.

b) Tank boundaries

Tanks for fresh water or fuel oil, or any other tanks which are not intended to be kept entirely filled in service, are to have divisions or deep swashes as may be required to minimize the dynamic stress on the structure.

The arrangement of all tanks, together with their intended service and the height of the overflow pipes, is to be clearly indicated on the plans submitted for approval.

**4.2.4 Closing appliances (1/7/2014)**

a) General requirements related to watertight integrity

- 1) The means to ensure the watertight integrity of internal openings are to comply with the following:
  - Doors which are not normally closed are to be remotely controlled from a manned control station and are also to be operable locally from each side.
  - Open/shut indicators are to be provided at a manned control station. Any other doors are to be normally kept closed under the Master's responsibility.
- 2) All downflooding openings, the lower edge of which is submerged when the unit is inclined to the first intercept between the righting moment and wind

heeling moment curves in any intact or damaged condition, are to be fitted with a suitable watertight closing appliance, such as closely spaced bolted covers.

In any case, the lower edges of air pipes (regardless of closing appliances), ventilators, ventilation intakes and outlets, non-watertight hatches and weathertight doorways are not to be submerged.

Openings which may be submerged include man-holes fitted with closed bolted covers, small hatches (see Note 1) and sidescuttles of the opening type.

Note 1: Small hatches, which may be submerged in the event of damage, are those which are normally used for access by personnel. Such openings are to be closed by approved quick-acting watertight covers of steel or equivalent material. An alarm system (e.g. light signal) is to be arranged showing personnel both locally and at a central position (e.g. central control ballast station) whether the hatch covers in question are open or closed. In addition, a notice to the effect that the closing appliance is to be closed while the unit is afloat and is only to be used temporarily is to be fitted locally. Such openings are not to be regarded as emergency means of escape.

- 3) Where flooding of chain lockers or other buoyant volumes may occur, the openings to these spaces are to be considered as downflooding points.

b) General requirements related to weathertight integrity

External openings fitted with appliances to ensure weathertight integrity, which are used during the operation of the unit while afloat are not to be submerged when the unit is inclined to an angle necessary to comply with the requirements of intact and damage stability.

**4.2.5 Freeboard (1/7/2014)**

- a) The minimum freeboard is to be determined on the basis of meeting the applicable intact stability, damage stability and structural requirements. The freeboard is not to be less than that computed from the Convention where applicable.
- b) The requirements of the 1966 Load Line Convention with respect to weathertightness and watertightness of decks, superstructures, deckhouses, doors, hatchway covers, other openings, ventilators, air pipes, scuppers, inlets and discharges, etc., are to be applied.

## SECTION 12

# PROTECTIVE COATINGS IN WATER BALLAST TANKS (COAT-WBT)

### 1 General

#### 1.1 Application

##### 1.1.1 (1/7/2006)

This Section provides the criteria for the assignment of the additional class notation **COAT-WBT**, in accordance with Pt A, Ch 1, Sec 2, [6.14.12], to ships of new construction whose water ballast tanks have been provided with protective coatings complying with the requirements of this Section.

The criteria for retaining the additional class notation **COAT-WBT**, which is subject to the coating system being maintained in or restored to GOOD condition, according to the definition given in Pt A, Ch 2, Sec 2, [2.2.12], during intermediate or class renewal surveys, are dealt with in Pt A, Ch 5, Sec 12, [11].

The additional class notation **COAT-WBT** also covers protective coatings that are applied in double-side skin spaces arranged in bulk carriers of 150 m in length and upward.

##### 1.1.2 (1/7/2006)

The criteria for the selection, application and maintenance of protective coatings in water ballast tanks, provided in this Section, are based on the following international regulations and standard:

- a) Regulation 3-2 of Part A-1, Chapter II-1 of SOLAS Convention 1974, which compulsorily applies to oil tankers and bulk carriers constructed on or after 1 July 1998, stating that "All dedicated seawater ballast tanks shall have an efficient corrosion prevention system, such as hard coating or equivalent. The coating is to preferably

be of light colour. The scheme for the selection, application and maintenance of the system shall be approved by the Administration, based on guidelines adopted by the Organisation. Where appropriate, sacrificial anodes shall also be used";

- b) IMO Resolution A.798(19) "Guidelines for the selection, application and maintenance of corrosion protection systems of dedicated seawater ballast tanks", referred to in the above-mentioned SOLAS regulation;

The reference "coating performance standard" for the assignment of the notation is the "Performance standard for protective coatings for dedicated seawater ballast tanks in all types of ships and double-side skin spaces of bulk carriers", adopted by IMO with Resolution MSC.215(82) on 8 December 2006. The basic coating system requirements are indicated in Tab 2.

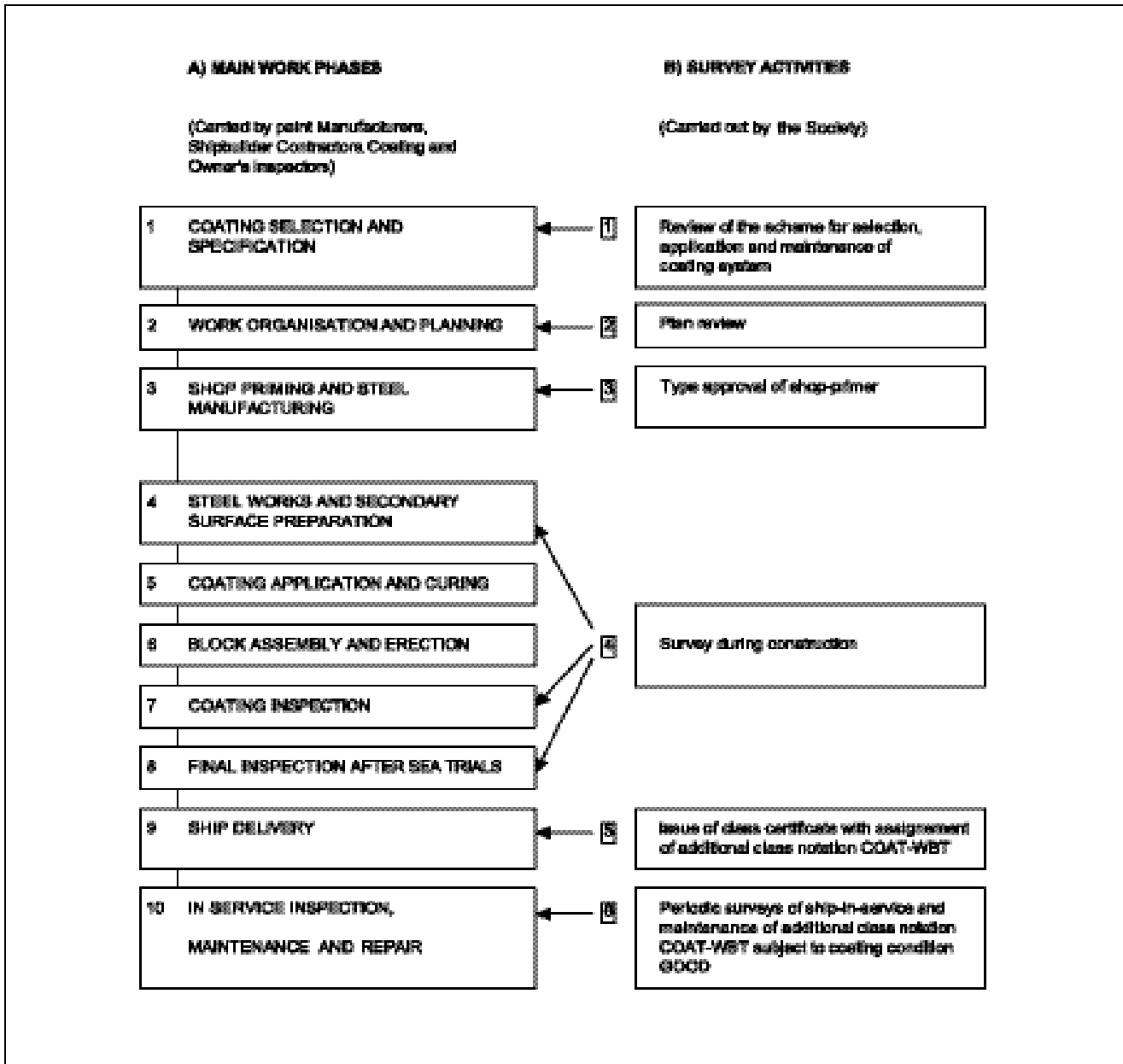
A different "coating performance standard", which may have been chosen in the agreement between the shipyard and the Owner, may be accepted as a reference standard provided that the Society deems it at least equivalent to the above-mentioned standard.

The reference "coating performance standard" will be appended as an enclosure to the Certificate of Classification of those ships to which the notation is assigned.

##### 1.1.3 (1/7/2006)

The assignment of the notation **COAT-WBT** is subject to the verification of the "main work phases" indicated in Tab 1, schedule A) by means of the "survey activities" identified at the milestones indicated in Tab 1, schedule B), as described in [3].

Table 1 : Main work phases and survey activities for the assignment of the notation COAT-WBT



1.2 Definitions

1.2.1 (1/7/2006)

For the purpose of this Section the following definitions apply:

- a) **Ballast spaces:** are spaces that can be used for storing ballast water. They normally include, but are not limited to, ballast tanks as defined in Resolution A.798(19) and Resolution A.744(18) and tanks which, according to the ship's loading manual, can be used for both cargo and ballast;
- b) **Cathodic protection:** is a technique to prevent corrosion of a metal surface by making an electrochemical con-

tact between the substrate and a metal easier to be corroded, i.e. zinc, magnesium, which in this case is sacrificed to preserve the less noble metal such as steel;

- c) **Curing:** is a complex of chemical phenomena which cause the polymerisation of the binder of the paint with formation of a three-dimensional molecular structure insoluble in the original solvents of the binder;
- d) **Curing time:** is the time required by a coating to reach its complete properties and mechanical characteristic;
- e) **Dew point:** is the temperature at which air is saturated with moisture;

- f) **Dust:** is loose particle matter present on a surface prepared for painting arising from blast-cleaning or other surface preparation processes, or resulting from the action of the environment;
- g) **Edge grinding:** is the treatment of edges before secondary surface preparation;
- h) **Hard coating:** is a coating that chemically converts during its curing process or a non-convertible air drying coating which may be used for maintenance purposes. It can be either inorganic or organic;
- i) **NDFT:** is the nominal dry film thickness of coating. 90/10 practice means that 90% of all thickness measurements are to be greater than or equal to NDFT and none of the remaining 10% measurements is to be below 0,9 x NDFT;
- j) **Primer coat:** is the first coating applied in the shipyard (to differentiate it from shop primer);
- k) **Shop primer:** is the prefabrication primer coating applied to steel plates and profiles in thin film, often in an automatic painting shop;
- l) **Solvent:** is a volatile liquid capable of completely dissolving a given binder;
- m) **Stripe coating:** is an application, normally by brush or roller, of one or more coating layers on locations where it is not easy to achieve the final total dry film coating thickness with the simple spray application;
- n) **Target useful life:** is the target value, in years, of the durability for which the coating system is designed. It is noted that the design of a coating system includes criteria for selection of the coating and for its proper application;
- o) **Technical Data Sheet:** is the paint Manufacturer's Product Data Sheet, which contains detailed technical instructions and information relevant to the coating and its application;
- p) **Thinner:** is a volatile liquid that does not necessarily dissolve the binder, but which is capable of reducing the viscosity of the binder solution (vehicle), for example by reducing the viscosity of a paint spraying consistency.

## 2 Coating selection and specification

### 2.1 General Principles

#### 2.1.1 (1/7/2006)

The ability of the coating system to reach its target useful life depends on the selected type of coating system, steel preparation, application and coating inspection and maintenance. All these aspects contribute to the good performance of the coating system.

#### 2.1.2 (1/7/2006)

Inspections of surface preparation and coating processes are to be agreed upon between the Owner, the shipyard and the coating Manufacturer and submitted to the Society for review, prior to the commencement of the shipbuilding process, in order to check that they contain at least the information shown in Tab 7 and that it complies with the basic coating system requirements shown in Tab 2. Clear evi-

dence of these inspections is to be reported and be included in the Coating Technical File (see [2.2]).

#### 2.1.3 (1/7/2006)

The following aspects are to be taken into account for achieving the required coating performance:

- a) it is essential that the agreed technical specifications, procedures and various different steps in the coating application process (including but not limited to surface preparation) are strictly followed by the shipbuilder, in order to prevent premature decay and/or deterioration of the coating system;
- b) the effectiveness of these Rule requirements can be improved by adopting measures at the ship design stage such as reducing scallops, using rolled profiles, avoiding complex geometric configurations and ensuring that the structural configuration permits easy access for tools and to facilitate cleaning, drainage and drying of the space to be coated;
- c) these Rule requirements are based on experience from Manufacturers, shipyards and ship operators and are not intended to exclude suitable alternative systems or innovative approaches that might be developed and applied in the future, provided that they demonstrate a level of performance at least equivalent to that specified in this Section. Acceptance criteria for alternative systems are given in [2.8].

#### 2.1.4 (1/7/2006)

The class notation **COAT-WBT** is not intended to be and shall not amount to a warranty of good performance of the coating nor does it replace the contractor warranty granted by the shipyard and/or paint Manufacturer or Supplier.

## 2.2 Coating Technical File

#### 2.2.1 (1/7/2006)

Specification of the coating system applied to the seawater ballast tanks, records of the shipyard's and Owner's coating work, and detailed criteria for coating selection, job specifications, inspection, maintenance and repair are to be documented in the Coating Technical File, which is to be reviewed by the Society.

#### 2.2.2 (1/7/2006)

The Coating Technical File is to contain at least the following items relating to this standard and is to be delivered by the shipyard at new ship construction stage:

- a) copy of Statement of Compliance or Type Approval Certificate;
- b) copy of Technical Data Sheet, including:
  - product name and identification mark and/or number;
  - materials, components and composition of the coating system, colours;
  - minimum and maximum dry film thickness;
  - application methods, tools and/or machines;
  - condition of surface to be coated (de-rusting grade, cleanness, profile, etc.); and
  - environmental limitations (temperature and humidity);

- c) shipyard work records of coating application, including:
  - applied actual space and area (in square metres) of each compartment;
  - applied coating system;
  - time of coating, thickness, number of layers, etc.;
  - ambient condition during coating; and
  - method of surface preparation;
- d) procedures for inspection and repair of coating system during ship construction;
- e) coating log issued by the coating inspector - stating that the coating was applied in accordance with the specifications to the satisfaction of the coating supplier representative and specifying deviations from the specifications (examples of a Daily Log and Non-conformity Report are given in Tab 4 and Tab 5, respectively);
- f) shipyard's verified inspection report, including:
  - completion date of inspection;
  - result of inspection;
  - remarks (if given); and
  - inspector's signature; and
- g) procedures for in-service maintenance and repair of coating system.

**2.2.3 (1/7/2006)**

Maintenance, repair and partial re-coating activities are to be recorded in the Coating Technical File. For coating maintenance and repair, reference is to be made to IACS Recommendation 87 "Guidelines for Coating Maintenance and Repair for Ballast tanks and Combined Cargo/Ballast tanks on Oil Tankers".

**2.2.4 (1/7/2006)**

If full re-coating is carried out, the items specified in [2.2.2] are to be recorded in the Coating Technical File.

**2.2.5 (1/7/2006)**

The Coating Technical File is to be kept on board and maintained throughout the life of the ship.

**2.3 Health and safety**

**2.3.1 (1/7/2006)**

The shipyard is responsible for implementation of national regulations to ensure the health and safety of individuals and to minimise the risk of fire and explosion.

**2.4 Coating Standard**

**2.4.1 Performance Standard (1/7/2006)**

This coating performance standard is based on specifications and requirements which intend to provide a target useful life of 15 years, which is considered to be the time period, from initial application, over which the coating system is intended to remain in "GOOD" condition. The actual useful life will vary, depending on numerous variables including actual conditions encountered in service.

**2.4.2 Permanent means of access (1/7/2006)**

It is recommended that this standard is to be applied, to the extent possible, to those portions of permanent means of access provided for inspection, not integral to the vessel structure, such as rails, independent platforms, ladders, etc. Other equivalent methods of providing corrosion protection for the non-integral items may also be used provided they do not impair the performance of the coatings of the surrounding structure. Access arrangements that are integral to the vessel structure, such as increased stiffener depths for walkways, stringers, etc., are to fully comply with this standard.

**2.4.3 Other items within ballast tanks (1/7/2006)**

It is also recommended that supports for piping, measuring devices, etc., should be coated in accordance with the non-integral items indicated in [2.4.2].

**2.4.4 Basic coating requirements (1/7/2006)**

The requirements for protective coating systems to be applied at ship construction for water ballast tanks meeting the performance standard specified in [2.4.1] are listed in Tab 2.

Coating Manufacturers are to provide a specification of the protective coating system to satisfy the requirements of Tab 2.

The Society will verify the Technical Data Sheet and Statement of Compliance or Type Approval Certificate for the protective coating system.

The shipyard is to apply the protective coating in accordance with the verified Technical Data Sheet and its own verified application procedures.

**Table 2 : Basic coating system requirements for the notation COAT-WBT**

Item	Requirement	Reference standard
1 - Design of coating system		
a) Selection of the coating system	<p>The selection of the coating system is to be considered by the parties involved with respect to the service conditions and planned maintenance. The following aspects, among other things, should be considered:</p> <ul style="list-style-type: none"> <li>(i) location of space relative to heated surfaces;</li> <li>(ii) frequency of ballasting and deballasting operations;</li> <li>(iii) required surface conditions;</li> <li>(iv) required surface cleanliness and dryness;</li> <li>(v) supplementary cathodic protections, if any (where coating is supplemented by cathodic protection, the coating is to be compatible with the cathodic protection system).</li> </ul> <p>Coating Manufacturers are to have products with documented satisfactory performance records and technical data sheets. The Manufacturers are also to be capable of rendering adequate technical assistance. Performance records, technical data sheets and technical assistance (if given) are to be recorded in the Coating Technical File. Coatings for application underneath sun-heated decks or on bulkheads forming boundaries of heated spaces are to be able to withstand repeated heating and/or cooling without becoming brittle.</p>	
b) Coating type	<p>Epoxy based systems</p> <p>Other coating systems are to have performance according to the test procedure in App 1.</p> <p>A multi-coat system with each coat of contrasting colour is recommended.</p> <p>The top coat is to be of a light colour in order to facilitate in-service inspection.</p>	
c) Coating pre-qualification test	<p>Epoxy based systems tested in a laboratory prior to the date of entry into force of this standard, by a method corresponding to the test procedure in App 1 or equivalent, meeting at least the requirements for rusting and blistering, or which have documented field exposure for 5 years with a final coating condition of not less than "GOOD", may also be accepted.</p> <p>For all other systems, testing according to the procedure in App 1, or equivalent, is required.</p>	
d) Job specification	<p>There are to be a minimum of two stripe coats and two spray coats, except that the second stripe coat, by way of welded seams only, may be reduced in scope where it is proven that the NDFT can be met by the coats applied in order to avoid unnecessary over thickness. Any reduction in scope of the second stripe coat is to be fully detailed in the Coating Technical File.</p> <p>Stripe coats are to be applied by brush or roller. A roller is to be used for scallops, ratholes, etc. only.</p> <p>Each main coating layer is to be appropriately cured before application of the next coat, in accordance with the coating Manufacturer's recommendations. Surface contaminants such as rust, grease, dust, salt, oil, etc. are to be removed prior to painting with a proper method according to the paint Manufacturer's recommendation. Abrasive inclusions embedded in the coating are to be removed.</p> <p>Job specifications are to include the dry-to-recoat times and walk-on time given by the Manufacturer.</p>	

Item	Requirement	Reference standard
e) NDFT (nominal total dry film thickness)	NDFT 320 µm with 90/10 rule for epoxy based coatings, other systems to coating Manufacturer's specifications. Maximum total dry film thickness according to Manufacturer's detailed specifications. Care is to be taken to avoid increasing the thickness in an exaggerated way. Wet film thickness is to be regularly checked during application. Thinner is to be limited to those types and quantities recommended by the Manufacturer.	Type of gauge and calibration in accordance with SSPC-PA2
2. Primary surface preparation		
a) Blasting and profile	Sa 2½, with profiles between 30-75 µm Blasting is not to be carried out when: (i) the relative humidity is above 85%; or (ii) the surface temperature of steel is less than 3°C above the dew point. Checking of the steel surface cleanliness and roughness profile is to be carried out at the end of the surface preparation and before the application of the primer, in accordance with the Manufacturer's recommendations.	ISO 8501-1 ISO 8503-1/3
b) Water soluble salt limit equivalent to NaCl	≤ 50 mg/ m <sup>2</sup> of sodium chloride (NaCl)	ISO 8502-6 Extraction Conductivity measured in accordance with ISO 8502-9
c) Shop primer	Zinc containing inhibitor free zinc silicate based or equivalent. Compatibility with main coating system is to be confirmed by the coating Manufacturer.	
3. Secondary surface preparation		
a) Steel condition	The steel surface is to be prepared so that the coating selected can achieve an even distribution at the required NDFT and have an adequate adhesion by removing sharp edges, grinding weld beads and removing weld spatter and any other surface contaminant in accordance with ISO 8501-3 grade P2. Edges are to be treated to a rounded radius of minimum 2 mm, or subjected to three pass grinding or at least equivalent process before painting.	ISO 8501-3
b) Surface treatment	Sa 2½ on damaged shop primer and welds. Sa 2 removing at least 70% of intact shop primer which has not passed a pre-qualification certified by test procedures specified in 1.c) of this Table. If the complete coating system comprising epoxy based main coating and shop primer has passed a pre-qualification certified by test procedures specified in 1.c) of this Table, intact shop primer may be retained provided the same epoxy coating system is used. The retained shop primer is to be cleaned by sweep blasting, high-pressure water washing or equivalent method. If a zinc silicate shop primer has passed the pre-qualification test specified in 1.c) of this Table, as part of an epoxy coating system, it may be used in combination with other epoxy coatings certified under the same test, provided that the compatibility has been confirmed by the Manufacturer by the test in accordance with App 1.	ISO 8501-1



Item	Requirement	Reference standard
c) Surface treatment after erection	Butts St 3 or better or Sa 2 <sup>1/2</sup> where practicable. Small damage up to 2% of total area: St 3. Contiguous damage over 25 m <sup>2</sup> or over 2% of the total area of the tank, Sa 2 <sup>1/2</sup> is to be applied. Coating in overlap to be feathered.	ISO 8501-1
d) Profile requirements	In the case of full or partial blasting 30-75 µm, otherwise as recommended by the coating Manufacturer.	ISO 8501-1/3
e) Dust	Dust quantity rating "1" for dust size class "3", "4" or "5". Lower dust size classes are to be removed if visible on the surface to be coated without magnification.	ISO 8502-3
f) Water soluble salts limit equivalent to NaCl after blasting/grinding	≤ 50 mg/ m <sup>2</sup> of sodium chloride (NaCl)	ISO 8502-6 Extraction Conductivity measured in accordance with ISO 8502-9
g) Oil contamination	No oil contamination.	
4. Miscellaneous		
a) Ventilation	Adequate ventilation is necessary for the proper drying and curing of coating. Ventilation is to be maintained throughout the application process and for a period after application is completed, as recommended by the coating Manufacturer.	
b) Environmental conditions	Coating is to be applied under controlled humidity and surface conditions, in accordance with the Manufacturer's specifications. In addition, coating is not to be applied when: (i) the relative humidity is above 85%; or (ii) the surface temperature is less than 3°C above the dew point.	
c) Testing of coating	Destructive testing is to be avoided. Dry film thickness is to be measured after each coat for quality control purposes and the total dry film thickness is to be confirmed after completion of final coat, using appropriate thickness gauges.	ISO 19840 Annex 3
d) Repair	Any defective areas, e.g. pin-holes, bubbles, voids, etc., are to be marked up and appropriate repairs effected. All such repairs are to be re-checked and documented.	

## 2.5 Coating system approval

### 2.5.1 (1/7/2006)

Results from prequalification tests of the coating system (see 1.c) of Tab 2) are to be documented, and a Statement of Compliance or Type Approval Certificate is to be issued if found satisfactory by a third party, independent of the coating Manufacturer.

## 2.6 Coating inspection requirements

### 2.6.1 Inspector qualification (1/7/2006)

The inspections indicated in the following paragraphs are to be carried out by qualified coating inspectors certified to NACE Level II or FROSIO level Red, or equivalent as verified by the Society.

### 2.6.2 Records of inspections (1/7/2006)

Results from the inspections indicated in [2.6.3] are to be recorded by the inspector, made available to the Interested Parties, including the attending Surveyor of the Society, and included in the Coating Technical File (refer to Tab 4 - Example of Daily Log and Tab 5 - Non-conformity Report).

### 2.6.3 Inspection items (1/7/2006)

Coating inspectors are to inspect surface preparation and coating application during the coating process by carrying out, as a minimum, those inspection items listed in Tab 3. Emphasis is to be placed on initiation of each stage of surface preparation and coating application, as improper work is extremely difficult to correct later in the coating progress. Representative structural members are to be non-destructively examined for coating thickness. The inspector is to verify that appropriate collective measures have been carried out.

## 2.7 Verification requirements

### 2.7.1 (1/7/2006)

Prior to reviewing the Coating Technical File for the particular ship under construction, the Society is to carry out the following:

- a) check that the Technical Data Sheet and Statement of Compliance or Type Approval Certificate comply with the requirements of this Section;
- b) check that the coating identification on representative containers is consistent with the coating identified in the Technical Data Sheet and Statement of Compliance or Type Approval Certificate;
- c) check that the inspector is qualified in accordance with the qualification standards, as indicated in [2.6.1];
- d) check that the inspector's reports of surface preparation and the coating's application indicate compliance with the Manufacturer's Technical Data Sheet and Statement of Compliance or Type Approval Certificate; and
- e) monitor implementation of the coating inspection requirements.

## 2.8 Alternative systems

### 2.8.1 (1/7/2006)

All systems that are not an epoxy based system applied according to Tab 2 are defined as an alternative system.

### 2.8.2 (1/7/2006)

The requirements of this Section are based on recognised and commonly used coating systems. It is not meant to exclude other, alternative, systems with proven equivalent performance, for example non-epoxy based systems.

### 2.8.3 (1/7/2006)

Acceptance of alternative systems will be subject to documented evidence that they ensure a corrosion prevention performance at least equivalent to that indicated in this Section.

### 2.8.4 (1/7/2006)

As a minimum, the documented evidence is to consist of satisfactory performance corresponding to that of a coating system, which conforms to the requirements, indicated in [2.4], a target useful life of 15 years in either actual field exposure for 5 years with final coating condition not less than "GOOD" or laboratory testing. Laboratory test is to be conducted in accordance with the test procedure given in App 1.

**Table 3 : Inspection items to be carried out during ship construction**

Construction stage	Inspection items
Primary surface preparation	<ol style="list-style-type: none"> <li>a) The surface temperature of steel, the relative humidity and the dew point are to be measured and recorded before the blasting process starts and at times of sudden changes in weather.</li> <li>b) The surface of steel plates is to be tested for soluble salt and checked for oil, grease and other contamination.</li> <li>c) The cleanliness of the steel surface is to be monitored in the shop primer application process.</li> <li>d) The shop primer material is to be confirmed as meeting the requirements of 2.c of Tab 2.</li> </ol>
Thickness	If compatibility with the main coating system has been declared, then the thickness and curing of the zinc silicate shop primer are to be confirmed as conforming to the specified values.
Block assembly	<ol style="list-style-type: none"> <li>a) After completing construction of the block and before secondary surface preparation starts, a visual inspection for steel surface treatment, including edge treatment, is to be carried out. Any oil, grease or other visible contamination is to be removed.</li> <li>b) After blasting/grinding/cleaning and prior to coating, a visual inspection of the prepared surface is to be carried out. On completion of blasting and cleaning and prior to the application of the first coat of the system, the steel surface is to be tested for levels of remaining soluble salts in at least one location per block.</li> <li>c) The surface temperature, the relative humidity and the dew point are to be monitored and recorded during the coating application and curing.</li> <li>d) Inspection is to be performed of the steps in the coating application process mentioned in Tab 2.</li> <li>e) DFT measurements are to be taken to prove that the coating has been applied to the thickness as specified and outlined in Tab 6.</li> </ol>
Erection	<ol style="list-style-type: none"> <li>a) Visual inspection for steel surface condition, surface preparation and verification of conformance to other requirements in Tab 2 and the agreed specification is to be performed.</li> <li>b) The surface temperature, the relative humidity and the dew point are to be measured and recorded before coating starts and regularly during the coating process.</li> <li>c) Inspection is to be performed of the steps in the coating application process mentioned in Tab 2.</li> </ol>

Table 4 : Example of a Daily Log

DAILY LOG					Sheet No:			
Hull no.:			Tank/Hold no.:		Database:			
Part of structure:								
<b>SURFACE PREPARATION</b>								
Method:					Rounding of edges:			
Abrasive:					Area (m <sup>2</sup> ):			
Surface temperature:					Grain size:			
Relative humidity (max):					Air temperature:			
Standard achieved:					Dew point			
COMMENTS:								
Job no.:			Date:		Signature:			
<b>COATING APPLICATION</b>								
<b>Method:</b>								
Coat no.	System	Batch no.	Date	Air temp.	Surface temp.	RH%	Dew point	DFT meas. (1)
(1) Measured minimum and maximum WFT (Wet Film Thickness) and DFT readings to be attached to Daily Log.								
COMMENTS:								
Job no.:			Date:		Signature:			

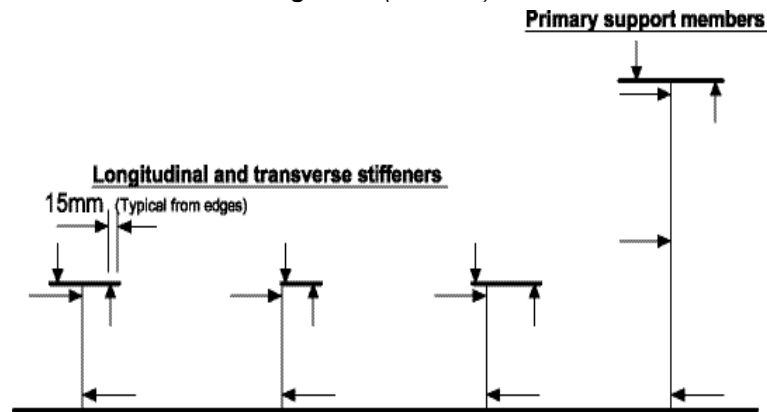
**Table 5 : Example of Non-conformity Report**

NON-CONFORMITY REPORT		Sheet No:	
Hull no.:	Tank/Hold no.:	Database:	
Part of structure:			
<b>DESCRIPTION OF THE INSPECTION FINDINGS</b>			
Description of findings			
Reference document (daily log):			
Action taken:			
Job no.:	Date:	Signature:	

**Table 6 : Dry Film Thickness measurements**

The following verification checkpoints of DFT are to be taken:	
(i)	one gauge reading per 5 m <sup>2</sup> of flat surface areas;
(ii)	one gauge reading at 2 to 3 metre intervals and as close as possible to tank boundaries, but not further than 15 mm from edges of tank boundaries;
(iii)	longitudinal and transverse stiffening members: one set of gauge readings as shown in Fig 1, taken at 2 to 3 metres run and not less than two sets between primary support members;
(iv)	three gauge readings for each set of primary support members and 2 gauge readings for each set of other members as indicated by the arrows in Fig 1;
(v)	for primary support members (girders and transverses) one set of gauge readings for 2 to 3 metres run as shown in Fig 1, but not less than three sets;
(vi)	around openings one gauge reading from each side of the opening;
(vii)	five gauge readings per square metre (m <sup>2</sup> ) but not less than three gauge readings taken at complex areas (i.e. large brackets of primary support members); and
(viii)	additional spot checks to be taken to verify coating thickness for any area considered necessary by the coating inspector.

Figure 1 (1/7/2006)



Note: Arrows of diagram indicate critical areas and are to be understood to mean indication for both sides.

**Table 7 : Documentation to be included in the "Coating Selection, Application and Maintenance Scheme"**

<b>1. GENERAL</b>
1.1 Evidence of explicit agreement between Owner, shipyard and paint Manufacturer on the scheme and its contents
1.2 Manufacturer's evidence of product quality and ability to meet the agreed coating requirements
1.3 Evidence of shipyard's and /or its subcontractor's experience in coating application
<b>2. TANKS TO BE COATED</b>
2.1 List of seawater ballast tanks to be coated identifying the coating system for each tank, including colour
2.2 Identification of tanks whose surfaces to be coated are underneath sun-heated decks or are part of bulkheads forming boundaries of heated cargo or heated bunker spaces
2.3 Identification of tanks where a cathodic protection system is foreseen in addition to a coating system
<b>3. COATING SELECTION</b>
3.1. Paint Manufacturer's technical product data sheet for each product (hard coating or equivalent)
3.2 Paint Manufacturer's documentation of satisfactory service performance
3.3 Paint Manufacturer's data on laboratory tests carried out, and related standard adopted, to verify the suitability for the intended product
3.4 Paint Manufacturer declaration that the coating is able to withstand repeated heating (for tanks listed under 2.2 above)
3.5 Paint Manufacturer's declaration of coating compatibility with the cathodic protection system (for tanks listed under 2.3 above)
<b>4. COATING APPLICATION</b>
4.1 Surface preparation procedures and standards, selected in accordance with paint Manufacturer's recommendations and including inspection points and methods
4.2 Procedures for coating application, including inspection points and methods
4.3 Range of humidity, surface temperature and ventilation conditions during and after coating application
4.4 Number of coats and minimum/maximum limits in dry film thickness (DFT) of each coat; DFT measuring method
4.5 Over-coating time at different temperatures
4.6 Criteria agreed upon for inspection and acceptance of surface preparation and coating application. Agreed format for the inspection reports
4.7 Paint Manufacturer's Material Safety Data Sheet (MSDS) for each selected product.
4.8 Owner's, paint Manufacturer's and shipyard's explicit agreement to take all safety precautions to reduce health and other safety risks
<b>5. MAINTENANCE OF THE COATING SYSTEM</b>
5.1 Maintenance scheme for the coating system
5.2 Indications on replacement of the sacrificial anodes and the inspection of coating around anodes (only when the coating is supplemented with cathodic protection)

### 3 Survey activities

#### 3.1 Review of the scheme for selection and application of coating system

##### 3.1.1 (1/7/2006)

The selection of a coating system on water ballast tanks is to take into consideration several factors affecting corrosion of steel structures, including frequency of ballasting/deballasting, partial or complete filling, temperature of cargo in adjacent cargo tanks, etc. All these factors, separately or in combination, can considerably affect the effectiveness of the corrosion protection system during ship life.

##### 3.1.2 (1/7/2006)

The coating selection is to take into account that:

- a) epoxy (or other equivalent hard coating) is only to be used for ballast tanks of new buildings;
- b) multi-coat layers of contrasting colour are recommended (the top coat layer is to be of a light colour in order to facilitate in-service inspection).

##### 3.1.3 (1/7/2006)

To comply with the requirements of this Section, the following aspects are to be taken into due account:

- a) the contractual coating specifications and the procedures and related working steps for its application as well as the paint Manufacturer's recommendations are to be agreed between the shipyard and Owner taking account of the reference standard and any changes thereto coming from the construction procedures and standards of the shipyard. The above-mentioned aspects will be dealt with during a pre-job meeting, to which the Society is to be invited as an observer;
- b) the coating specifications are to be made known to all Interested Parties, including the Society;
- c) all work is to be performed by skilled operators in a safe and workmanlike manner, in accordance with the agreed specifications;
- d) the coating inspections during the ship's construction are to be performed by qualified coating inspectors, who are to verify that the reference standard agreed between shipyard and Owner is complied with;
- e) coating damage, if any, during ship construction is to be properly repaired in order to avoid premature decay and deterioration of the coating system.

#### 3.2 Plan review

##### 3.2.1 (1/7/2006)

The Shipbuilder is to provide the Society with additional drawings of the internal water ballast tank structures showing compliance with the following aspects:

- a) internal structures, stiffeners and piping are to be designed to avoid, as far as possible, any entrapped

areas not subject to coating application, inspection and maintenance;

- b) burrs and sharp edges are to be rounded off, in accordance with the basic coating system requirements (e.g. three pass edge grinding of sharp edges) and any steel defects removed as listed in Tab 2;
- c) hollow components which are not accessible are to be sealed off completely and permanently, e.g. by welding them closed and leaving them filled with inert material (plastic foam or similar);
- d) if a cathodic protection system is installed, the number and position of sacrificial anodes are to be consistent with the specifications in the agreed scheme for coating selection, application and maintenance;
- e) the structural configuration of internal spaces is to be such as to permit easy access with tools for cleaning, drainage, ventilation and drying of the tanks necessary for coating inspection and repair during the ship life.

#### 3.3 Type approval of shop primer

##### 3.3.1 (1/7/2006)

Shop primers applied to steel plates and profiles are to be approved by the Society or another recognised organisation, in accordance with the requirements in Pt D, Ch 5, Sec 3.

##### 3.3.2 (1/7/2006)

The shipyard is to provide the Society with information confirming that all parameters of shop primer application are consistent with the paint Manufacturer's recommendations.

#### 3.4 Inspection and testing

##### 3.4.1 (1/7/2006)

The shipyard is to provide the Society with daily reports containing the results of the inspections carried out by representatives of the shipyard, Owner and paint Manufacturer during surface preparation and coating application.

##### 3.4.2 (1/7/2006)

At any time during construction the attending Surveyor is to be allowed to take samples of the coating material used for coating the ballast tanks, which may be analysed for verifying conformity with agreed coating specifications.

#### 3.5 Surface preparation survey

##### 3.5.1 (1/7/2006)

At any time during construction the attending Surveyor is to be allowed to carry out an inspection of surface preparation (e.g. blasting and grinding profiles) in order to verify on the spot compliance with the requirements given in Tab 2.

This survey may be carried out by the attending Surveyor concurrently with the inspection carried out by the shipyard, Owner or paint Manufacturer Inspectors, or with the survey carried out on the fabricated blocks to check their correspondence to the approved plans, or on any other appropriate occasion.

### 3.6 Coating application survey

#### 3.6.1 (1/7/2006)

After the completion of coating application in a compartment and before staging has been removed, the attending Surveyor is to be allowed to carry out spot checks of the coating application (e.g. after spray and stripe coats) to verify on the spot that it complies with the requirements given in Tab 2.

This survey may be carried out by the attending Surveyor concurrently with the inspection carried out by the shipyard, Owner or paint Manufacturer Inspectors, or with the survey carried out on the assembled blocks to check their correspondence to the approved plans, or on any other appropriate occasion.

#### 3.6.2 (1/7/2006)

After the staging has been removed, the attending Surveyor is to be allowed to carry out a visual inspection to check that there is no damage caused by mechanical and/or weld-

ing work. Any damage found to the coating is to be repaired in accordance with the technical coating specifications and paint Manufacturer's recommendations.

#### 3.6.3 (1/7/2006)

After the repairs have been completed, a final space inspection is to be carried out for acceptance. If the result is satisfactory, the space is to be closed immediately afterwards.

### 3.7 Final inspection after sea trials

#### 3.7.1 (1/7/2006)

The attending Surveyor is to be allowed to carry out a final inspection of the ballast tanks emptied after sea trials. Should any damage to coating be found, appropriate repairs are to be performed in accordance with the technical coating specifications and paint Manufacturer's recommendations before the ship is delivered. This survey may be concurrent with the final acceptance inspection carried out by shipyard, Owner and paint Manufacturer's Inspectors.

## SECTION 13

# CREW ACCOMMODATION AND RECREATIONAL FACILITIES ACCORDING TO THE MARINE LABOUR CONVENTION, 2006 (MLCDESIGN)

### 1 General

#### 1.1 Applications

##### 1.1.1 (1/4/2008)

The additional class notation **MLCDESIGN** is assigned, in accordance with Pt A, Ch 1, Sec 2, [6.14.16], to ships having crew accommodation and recreational facilities complying with the Marine Labour Convention, 2006 -Title 3 and with the requirements of this Section.

#### 1.2 Documentation to be submitted for approval

##### 1.2.1 Plans (1/4/2008)

Detailed plans of the on board crew accommodation and recreational facilities are to be submitted to the Society in triplicate for approval. These plans are to indicate the general arrangements and dimensions of:

- Rooms and other accommodation spaces;
- Heating and ventilation;
- Noise and vibration and other ambient factors;
- Sanitary facilities;
- Lighting;
- Hospital accommodation.

##### 1.2.2 Documentation to be put on board (1/4/2008)

The Owner is to put on board the ship the plans given in [1.2.1], and they are to be available to the Surveyor when a shipboard inspection is carried out.

### 2 Design requirements

#### 2.1 Basic Standard Requirements to obtain the additional class notation MLCDESIGN

##### 2.1.1 (1/4/2008)

The minimum standards for shipboard accommodation and recreational facilities are set out in paragraphs 6 to 17 of the Marine Labour Convention, 2006 - Title 3 as summarised in Tab 1.

A plan approval and shipboard inspection is to be carried out when the accommodation has been substantially altered and the **MLCDESIGN** additional class notation is to be re-issued.

**Table 1 : Basic Standard Requirements with reference to paragraphs 6 to 17 of the Marine Labour Convention, 2006 - Title 3 (1/4/2008)**

Accommodation and recreational facilities	Standard
General Insulation	<p>6(a) minimum permitted headroom: 203 cm</p> <p>6(b) the accommodation is to be adequately insulated</p> <p>6(c) in ships other than passenger ships, sleeping rooms are, in general, to be situated above the load line amidships or aft</p> <p>6(d) in passenger ships, , on condition that satisfactory arrangements are provided for ventilation and lighting, the competent authority may permit the location of sleeping rooms below the load line</p> <p>6(e) there are to be no direct openings into sleeping rooms from cargo and machinery spaces or from galleys, storerooms, drying rooms or communal sanitary areas; that part of a bulkhead separating such places from sleeping rooms and external bulkheads is to be efficiently constructed of steel or other approved substance and to be watertight and gas-tight</p>
Ventilation and heating	<p>7(a) sleeping rooms and mess rooms are to be adequately ventilated</p> <p>7(b) except for those regularly engaged in temperate climates, ships are to be equipped with air conditioning for seafarer accommodation, for any separate radio room and for any centralised machinery control room</p> <p>7(c) all sanitary spaces are to have ventilation to the open air, independently of any other part of the accommodation</p> <p>7(d) an appropriate heating system is to be provided, except in ships engaged exclusively on voyages in tropical climates</p>



Accommodation and recreational facilities	Standard
Lighting	8) Sleeping rooms and mess rooms are to be lit by natural light and provided with adequate artificial light
Sleeping rooms	<p>9(a) In ships other than passenger ships, an individual sleeping room is to be provided for each seafarer (exemptions may be granted for ships of less than 3000 gt or special purpose ships)</p> <p>9(b) separate sleeping rooms are to be provided for men and women</p> <p>9(d) a separate berth is to be provided for each seafarer in all circumstances</p> <p>9(e) berth's minimum inside dimensions: 198 cm by 80 cm</p> <p>9(f) floor area of single berth seafarers' sleeping rooms (reduced areas may be permitted in special circumstances):</p> <ul style="list-style-type: none"> <li>• 4,5 m<sup>2</sup> (gt&lt;3000)</li> <li>• 5,5 m<sup>2</sup> (3000&lt;gt&lt;10000)</li> <li>• 7 m<sup>2</sup> (gt&gt;10000)</li> </ul> <p>9(k) floor area of sleeping room in ships other than passenger ships and special purpose ships for seafarers who perform the duty of ship officers:</p> <ul style="list-style-type: none"> <li>• 7,5 m<sup>2</sup> per person (gt&lt;3000)</li> <li>• 8,5 m<sup>2</sup> per person (3000&lt;gt&lt;10000)</li> <li>• 10 m<sup>2</sup> per person (gt&gt;10000)</li> </ul> <p>9(i) floor area of sleeping rooms in passenger ships and special purpose ships for seafarers not performing the duty of ship officers:</p> <ul style="list-style-type: none"> <li>• 7,5 m<sup>2</sup> rooms accommodating 2 persons</li> <li>• 11,5 m<sup>2</sup> rooms accommodating 3 persons</li> <li>• 14,5 m<sup>2</sup> rooms accommodating 4 persons</li> </ul> <p>9(l) floor area of sleeping rooms in passenger ships and special purpose ships for seafarers performing the duty of ship officers:</p> <ul style="list-style-type: none"> <li>• 7,5 m<sup>2</sup> per person for junior officers (operational level)</li> <li>• 8,5 m<sup>2</sup> per person for senior officers (management level)</li> </ul> <p>9(n) for each occupant, the furniture is to include a clothes locker (minimum 475 litres) and a drawer (minimum 56 litres)</p> <p>9(o) each sleeping room is to be provided with a table or desk</p>
Mess rooms	10(a) located apart from sleeping rooms and as close as practicable to the galley (exemptions may be granted for ships of less than 3000 gt)
Sanitary facilities	<p>11(a) separate for men and for women</p> <p>11(b) easy access from the navigating bridge and the machinery space or near the engine room control centre (exemptions may be granted for ships of less than 3000 gt)</p> <p>11(c) a minimum of one toilet, one washbasin and one tub or shower or both for every six persons who do not have personal facilities</p> <p>11(d) with the exception of passenger ships, one washbasin with hot and cold fresh running water in each sleeping room</p> <p>11(e) hot and cold fresh running water in all wash places</p> <p>11(f) special arrangements and/or reductions may be granted for passenger ships normally engaged on voyages of not more than 4 hours</p>
Hospital	12) Ships carrying 15 or more seafarers and engaged on a voyage of more than three days' duration are to provide separate hospital accommodation to be used exclusively for medical purposes
Laundry facilities	13) Appropriately situated laundry facilities are to be provided
Open space	14) All ships are to have a space or spaces on open deck to which the seafarers can have access when off duty, which are of adequate area having regard to the size of the ship and the number of seafarers on board
Office(s)	15) All ships are to be provided with separate offices or a common ship's office for use by deck and engine departments (exemptions may be granted to ships of less than 3000 gt)
Recreational facilities	<p>16) Ship regularly trading in mosquito-infested ports are to be fitted with appropriate devices</p> <p>17) Appropriate seafarers' recreational facilities, amenities and services, as adapted to meet the special needs of seafarers who must live and work on ships, are to be provided on board for the benefit of all seafarers.</p>

## SECTION 14

## DIVING SUPPORT SHIPS (DIVINGSUPPORT)

### 1 General

#### 1.1 Applications

##### 1.1.1 (1/7/2009)

This Section provides the criteria for the assignment of the additional class notation **DIVINGSUPPORT** in accordance with Pt A, Ch 1, Sec 2, [6.14.17], to ships equipped with a diving system certified by the Society according to the "Rules for the classification of underwater units" (or certified by another QSCS Classification Society, see Pt A, Ch 1, Sec 1, [1.2.1]) and complying with the requirements of this Section.

The diving system is intended as the whole system and equipment as indicated in Pt E, Ch 2, Sec 3 of the "Rules for the classification of underwater units".

The additional class notation covers the following issues:

- the ship's ability to maintain its position during diving operations,
- the ship's stability during handling of diving equipment (such as lowering of diving bells into the sea),
- the hull structural arrangements related to the diving system, such as moonpool (launching and recovery well for bell) and lifting appliances,
- the electrical system to support the diving operations.

#### 1.2 Documents to be submitted

##### 1.2.1 (1/10/2008)

The documents listed in Tab 1 are to be submitted in addition to the documentation requested for the assignment of the additional class notation **DYNAPOS AM/AT R** and by the "Rules for loading and unloading arrangements and for other lifting appliances on board ships" for cranes and other lifting appliances for diving bell handling systems.

#### 1.3 Position keeping

##### 1.3.1 (1/10/2008)

The ship is to be able to maintain its position safely during diving operations. The ship is to be equipped with a dynamic positioning system complying with the requirements for the additional class notation **DYNAPOS AM/AT R** or other equivalent arrangement.

#### 1.4 Stability criteria

##### 1.4.1 Intact stability criteria during lifting of diving equipment (1/10/2008)

The following intact stability criteria are to be complied with:

- $\theta_c \leq 15^\circ$
- $GZ_C \leq 0,6 GZ_{MAX}$
- $A_1 \geq 0,4 A_{TOT}$

where:

$\theta_c$  : Heeling angle of equilibrium, corresponding to the first intersection between heeling and righting arms (see Fig 1)

$GZ_C, GZ_{MAX}$  : Defined in Fig 1

$A_1$  : Area, in m-rad, contained between the righting lever and the heeling arm curves, measured from the heeling angle  $\theta_c$  to the heeling angle equal to the lesser of:

- heeling angle  $\theta_R$  of loss of stability, corresponding to the second intersection between heeling and righting arms (see Fig 1)
- heeling angle  $\theta_F$ , corresponding to flooding of unprotected openings as defined in Sec 11, [2.1.4] (see Fig 1)

$A_{TOT}$  : Total area, in m rad, below the righting lever curve.

In the above formula, the heeling arm, corresponding to equipment lifting, is to be obtained, in m, from the following formula:

$$b = (P_d - Z_z) / \Delta$$

where:

$P$  : Equipment lifting mass, in t

$d$  : Transverse distance, in m, from diving equipment to the longitudinal plane (see Fig 1)

$Z$  : Mass, in t, of ballast used to right the ship, if applicable (see Fig 1)

$z$  : Transverse distance, in m, of the centre of gravity of  $Z$  to the longitudinal plane (see Fig 1)

$\Delta$  : Displacement, in t, in the loading condition considered.

The above check is to be carried out considering the most unfavourable situations of equipment lifting combined with the lesser initial metacentric height GM, corrected according to the requirements in Pt B, Ch 3, Sec 2, [4].

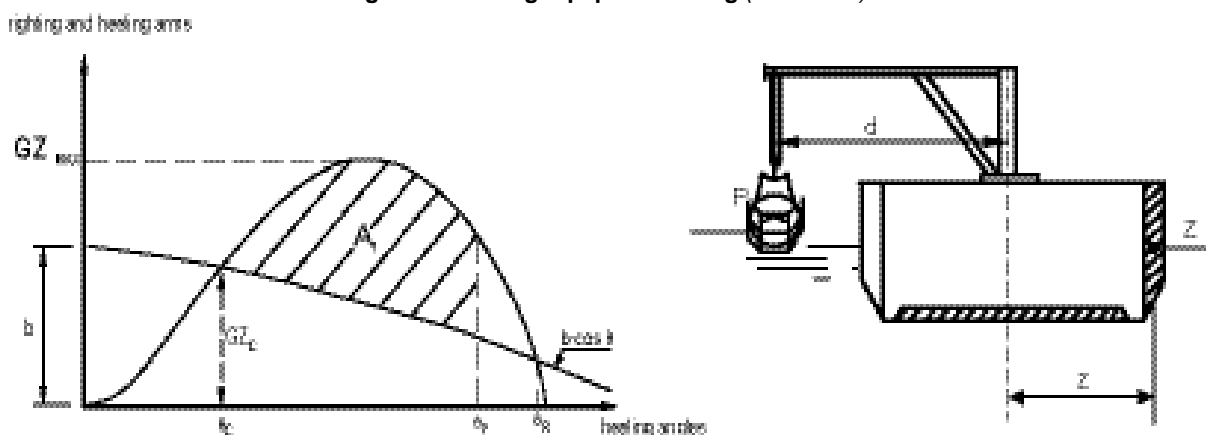
The residual freeboard of the ship during lifting operations in the most unfavourable stability condition is to be not less than 0,30 m. However, the heeling of the unit is not to produce in the lifting devices higher loads than those envisaged by the Manufacturer, generally expected to be  $5^\circ$  in the boom plane and  $2^\circ$  transversally in the case of a crane.

The vertical position of the centre of gravity of diving equipment is to be assumed in correspondence with the suspension point.

**Table 1 : Documents to be submitted (1/10/2008)**

No.	I/A (1)	Document
1	I	General arrangement of the diving system
2	A	Hull structures related to the arrangement of the diving system
3	A	Electrical load analysis of main and emergency source, showing diving system related loads
4	I	Plans showing electrical equipment arrangement
5	A	Single line diagrams of communication systems

(1) A = to be submitted for approval, in quadruplicate  
I = to be submitted for information, in duplicate

**Figure 1 : Diving equipment lifting (1/10/2008)**

## 1.5 Hull structural arrangements related to the diving system

### 1.5.1 General (1/10/2008)

The hull structures related to the arrangement of the diving system on the ship are to be designed with adequate strength and stiffness to sustain the loads induced by the system during rest and operation, in accordance with the general load and strength criteria in Pt B, Ch 7, App 1.

Pedestals and foundations also concern the ship's hull and are to comply with the above structural strength requirements.

### 1.5.2 Lifting appliances (1/10/2008)

Cranes and other lifting appliances for diving bell handling systems are to be certified according to the "Rules for loading and unloading arrangements and for other lifting appliances on board ships", as far as applicable.

## 1.6 Arrangement and installation of the diving system

### 1.6.1 General (1/10/2008)

The diving system is not to be located in spaces containing other machinery or in spaces where explosive gas-air mixtures may be present.

## 1.7 Electrical systems

### 1.7.1 Essential services (1/10/2008)

In addition to the primary and secondary essential services defined in Part C, Chapter 2, those services that need to be in continuous operation to:

- sustain the safety, health and environment in a hyperbaric environment
- monitor the divers by the crew
- support divers in the water, in a bell, in the decompression chambers are to be considered essential.

### 1.7.2 Emergency services (1/10/2008)

In addition to the emergency services defined in Part C, Chapter 2, those services that are essential for safety in an emergency condition are to be considered emergency services as well.

Examples of these services include:

- a) condition monitoring of emergency batteries
- b) launch and recovery system
- c) diving system emergency lighting
- d) diving system communication systems
- e) diving system life support systems including environmental monitoring equipment
- f) diving system heating systems
- g) alarm systems for the above services.

**1.7.3 Main source and emergency source**  
(1/10/2008)

The main source is to be capable of maintaining the essential services mentioned above for the period required to safely terminate the diving operation, including time for decompression of the divers.

The electrical installations essential to the safe completion of the mission are to be supplied from both main and emergency sources of electrical power.

The emergency source of electrical power is to be capable of supplying all connected loads and in particular the emergency users mentioned above, for the duration specified hereafter:

- a) all services supporting divers in the water, for at least 20 minutes (minimum time required to ensure that the divers are safely recovered in the bell or brought to the surface),
- b) all services supporting divers in a bell, for at least 24 hours (minimum time required to ensure that the divers are safely recovered in the decompression chambers or brought to the surface),
- c) all services supporting divers in the decompression chambers, at least for the required life-support time,

unless the diving system is provided with an emergency source complying with the above.

**1.7.4 Distribution systems** (1/10/2008)

Only insulated (IT) electrical distribution systems are permitted to supply a diving system. Being insulated, they are to be provided with a device capable of automatic insulation monitoring and, in the case of insulation failure, actuating switch-off and giving an alarm.

Alarm only may be used if a sudden switch-off of the equipment may cause danger to the divers.

Systems using double insulated apparatus or earth fault circuit-breakers will be considered on a case-by-case basis.

It is to be possible to disconnect power from each chamber or bell separately.

When the main power to the diving system is supplied via a distribution board, this board is to be supplied by two separate feeders from different sections of the main switchboard.

When the emergency power to the diving system is supplied by the ship, the supply is to be from the ship's emergency switchboard.

**1.7.5 Installation** (1/10/2008)

Tensile loads are not to be applied to electrical cables or wiring.

**1.7.6 Communication systems** (1/10/2008)

A communication system is to be arranged for direct two-way communication between the ship's control position and the following as applicable:

- diver in water,
- bell
- chamber (each compartment)
- diving system
- diving system handling position and emergency control station
- dynamic positioning room, navigation bridge.

An emergency means of communication between the control position and the diving system is to be available.

For diving bells, this may be a self-contained, through water communication system.

For diving bells, this may be a self-contained, through water communication system.

When means (e.g. TV) are arranged for visual observation of the divers in the bells and in the chamber compartments (or in general the persons in the diving system), a suitable connection to the relevant ship's control position is to be provided.

Means are to be available in the ship's control position to record communications with the diving system.

**1.7.7 Instrumentation** (1/10/2008)

Indication and operation of all essential life support conditions to and from the diving system are to be arranged at the appropriate control position.

## SECTION 15

# HIGH VOLTAGE SHORE CONNECTION (HVSC-NB AND HVSC)

### 1 General

#### 1.1 Application

##### 1.1.1 (1/5/2022)

The additional class notations **HVSC-NB** and **HVSC** are assigned in accordance with Pt A, Ch 1, Sec 2, [6.14.18] to ships fitted with high voltage shore connection (HVSC) systems complying with the requirements of this Section as follows:

- **HVSC-NB** for systems tested on board without any onshore facility connection test for communication and power circuits,
- **HVSC** for systems fully tested including at least one onshore facility connection test for communication and power circuits.

##### 1.1.2 (1/1/2022)

These requirements are additional to those applicable in other Parts of the Rules.

For specific requirements relevant to particular ship's types, annexes in IEC 80005 may be referred to.

##### 1.1.3 (1/1/2022)

On shore equipment and installations (including shore-based transformers, circuit-breakers, cables, connectors and on shore alarm, control and safety systems) are not covered by these requirements.

##### 1.1.4 (1/5/2022)

Assessment of the overall compatibility between ship and shore installation is necessary before connection and is not covered by this additional class notation.

Note 1: Where the requirements and recommendations of IEC/IEEE 80005-1 are complied with, high voltage shore supply arrangements are likely to be compatible for visiting ships for connection.

#### 1.2 Definitions

##### 1.2.1 (1/1/2022)

Cable management system: all equipment designed to control, monitor and handle the HV-flexible and control cables and their connection devices.

##### 1.2.2 (1/1/2022)

Equipotential bond monitoring device: device that monitors the equipotential bonding between two points.

##### 1.2.3 (1/1/2022)

Pilot contact: contact of the plug and socket-outlet, which signals correct plug connection and is a safety-related component.

#### 1.3 Documents to be submitted

##### 1.3.1 (1/1/2022)

The documents in Tab 1 are required.

The Society reserves the right to request the submission of additional documents in the case of non-conventional design or when it is deemed necessary for the evaluation of the systems and components.

### 2 Requirements for both ship's and shore systems

#### 2.1 General

##### 2.1.1 (1/1/2022)

A typical HVSC system consists of all hardware components necessary to electrically connect ship to shore such as plugs and sockets, transformers (where applicable), switchboards, (static or rotating) frequency converters and alarm, control and safety systems.

##### 2.1.2 (1/1/2022)

Protection and safety systems are to be designed based on the fail-safe principle and hard-wired.

##### 2.1.3 (1/7/2009)

Electrical power supply from an HVSC system is not to adversely affect the availability of main, auxiliary or emergency machinery, including ship sources of electrical power to allow ship power to be restored.

#### 2.2 Equipotential bonding

##### 2.2.1 (1/1/2022)

An equipotential bonding between the ship's hull and shore earthing system is to be foreseen.

##### 2.2.2 (1/1/2022)

Integrity of the equipotential bonding is to be continuously checked as a part of the ship shore safety circuit.

##### 2.2.3 (1/1/2022)

Loss of continuity in the equipotential bonding is to result in the shutdown of the HVSC and the ship system is to perform a standard restart after blackout.

Note 1: The adoption of special arrangements (e.g. detection of corrosion currents across the equipotential bonding circuit) against electrochemical corrosion is to be considered, especially in the case of aluminum ships.

##### 2.2.4 (1/1/2022)

As an alternative to the continuous monitoring of the equipotential bonding, periodic testing and maintenance of the bonding connection may be accepted on a case-by-case basis, considering the operative profile of the ship. Documentation is to be made available onboard as a reference for the surveyor in charge for survey.

**2.3 Compatibility**

**2.3.1 (1/7/2009)**

At least the following matters are to be considered when ship shore network compatibility is evaluated:

- nominal ratings of the shore supply, ship to shore connection and ship connection (power, alarm, control, safety and communication cables),
- maximum prospective short-circuit current (electrical system design, including short-circuit protective device rating, is to be suitable for the maximum prospective short-circuit current at the installation point),
- acceptable voltage variations at ship switchboards between no load and rated load (considering steady state and transient ship load demands),
- shore supply response to step changes in load,
- verification of ship equipment impulse withstand capability,
- configuration compatibility assessment of neutral point connection (where an on board transformer is not feasible, the neutral point treatment on the shore supply is to be able to adapt to various grounding philosophies),
- cable length,
- presence of hazardous areas.

**2.4 Failures**

**2.4.1 (1/7/2009)**

An alarm is to be given at the ship's manned station during HVSC system operation whenever a failure occurs on the HVSC system or in ship's systems required to maintain ready availability (for example preheating systems).

**2.4.2 (1/7/2009)**

The failure effect is to be analysed and the consequences found acceptable from the safety point of view.

**2.5 Location**

**2.5.1 (1/7/2009)**

HV equipment is to be located in access controlled spaces.

**2.5.2 (1/1/2022)**

In addition, at least the following matters are to be considered when ship shore equipment location is evaluated:

- the safe and efficient operation of the ship's bunkering, cargo handling and mooring systems
- interference with other ships' operations
- flow on the pier and to maintain open fire (or other emergency) lanes
- need for physical safeguards to prevent injuries (e.g. personnel falling from the shore or the ship because of HVSC system operations)
- all tidal conditions
- presence of hazardous areas.

**Table 1 : Documents to be submitted (1/1/2022)**

No.	(1)	Document
1	A	One line diagram of the HVSC system
2	A	Electrical Load Analysis (in shore supply condition)
3	I	Short-circuit calculation
4	A	Selectivity and coordination of the electrical protection
5	A	Diagrams of converters and switchboards (including information about Manufacturer, type and characteristics of circuit-breakers and protection)
6	A	Diagrams of alarm, control and safety system (including information about Manufacturer, type and characteristics of electronic equipment and location of the ship's manned station during HVSC system operation)
(1) A = to be submitted for approval, in quadruplicate		

**2.6 Short-circuit calculation and electrical load analysis**

**2.6.1 (1/7/2009)**

In calculating the maximum prospective short-circuit current, the source of current is to include the maximum number of generators which can be simultaneously connected (as far as permitted by any interlocking arrangements), the shore supply contribution and the maximum number of motors which are normally simultaneously connected in the system.

**2.6.2 (1/7/2009)**

The calculations may take into account any arrangements that:

- prevent permanent parallel connection of high voltage shore supply with ship sources of electrical power and/or,
- restrict the number of ship generators operating during parallel connection to transfer load,
- restrict load to be connected.

**2.6.3** (1/7/2009)

The maximum number of generators or transformers may be evaluated without taking into consideration short-term parallel operation for load transfer, provided that suitable interlocks are foreseen.

**2.7 Emergency shutdown and emergency stop****2.7.1** (1/7/2009)

Emergency shutdown system is to be provided to open instantaneously all shore connection circuit-breakers, when activated.

**2.7.2** (1/1/2022)

The high voltage power connections are to be:

- a) automatically earthed (so that they are safe to touch) immediately following the isolation from ship and shore electrical supply or
- b) arranged from manual earthing, routed and located such that personnel are prevented from access to live connection cables and live connection points by barriers and/or adequate distance(s) (see Note 1) under normal operational conditions.

Note 1: barriers and/or adequate distance(s) may be satisfied with operational procedures established to:

- restrict un-authorized access to HVSC spaces,
- control personnel access to HVSC spaces and areas when the HV connection is live with locking arrangements, and
- arrangement for the safe discharge of HV conductors.

**2.7.3** (1/1/2022)

Where connection equipment can move into a potentially hazardous area, all electrical powered HVSC equipment that is not certified safe type is to be isolated and only alternative a) in [2.7.2] is to be implemented.

**2.7.4** (1/7/2009)

Where earthing of shore equipment by ship equipment would not be permitted by the responsible shore authorities, alternative proposals for personnel protection and connection cable discharge may be considered.

**2.7.5** (1/1/2022)

The emergency shutdown system is to be activated in the event of:

- loss of continuity in the equipotential bonding circuit, if applicable (see [2.2.4]),
- over-tension on the flexible cable (mechanical stress),
- loss of any safety circuit,
- activation of any emergency stop buttons,
- activation of protection relays provided to detect faults on the HV connection cable or connectors and
- disengaging of power plugs from socket-outlets while HV connections are live.

**2.7.6** (1/1/2022)

Emergency stop push buttons, manually activating the emergency shutdown system, are to be provided at least at the:

- ship's manned control station during HVSC system operation,
- active cable management system control locations; and
- shore and ship circuit-breaker locations.

Additional emergency stop push buttons may also be provided at other locations, where considered necessary.

**2.7.7** (1/7/2009)

The emergency stop devices are to be clearly visible, protected against inadvertent operation. They are to require a manual action to reset.

**2.7.8** (1/7/2009)

An alarm is to be given at the ship's manned station during HVSC system operation, upon emergency shutdown activation. The alarm is to indicate the cause of the activation of the emergency shutdown system.

**3 Ship requirements****3.1 Power connection from shore****3.1.1** (1/7/2009)

A shore connection switchboard for the reception of the ship to shore connection is to be provided at a suitable location, near the supply point.

**3.1.2** (1/7/2009)

The shore connection switchboard is to comply with IEC 62271-200.

**3.1.3** (1/7/2009)

The switchboard is to include a circuit-breaker to protect the shipboard fixed electrical cables.

**3.1.4** (1/7/2009)

The following interlocks are required for correct system operation (isolation before earthing):

- circuit-breaker and disconnector are to be interlocked and
- disconnector and earthing switches are to be interlocked.

**3.1.5** (1/7/2009)

An automatic operated circuit-breaker and remote operated or manually operated earthing switch are to be provided.

**3.2 Instrumentation and protection****3.2.1** (1/1/2022)

The shore connection switchboard is to be equipped with:

- a voltmeter, all three phases,
- short-circuit devices: tripping and alarm,
- overcurrent devices: tripping and alarm,
- earth fault indicator: alarm
- unbalanced protection for systems with more than one ship inlet,
- battery backup adequate for at least 30 min. operation of all auxiliary circuits,

**3.2.2** (1/7/2009)

Alarms and indications are to be provided at the ship's manned station during HVSC system operation and at any other appropriate location for safe and effective operation.

**3.2.3** (1/7/2009)

Arrangements are to be provided to check the insulation between HVSC system conductors, and between the conductors and earth prior to the connection of the power supply.

**3.3 System separation**

**3.3.1** (1/7/2009)

Galvanic separation is to be provided between the onshore and on-board systems.

**3.3.2** (1/7/2009)

If necessary, means are to be provided to reduce transformer current in-rush and/or to prevent the starting of large motors, or the connection of other large loads, when an HV supply system is connected.

**3.4 Ship's power switchboard**

**3.4.1** (1/7/2009)

An additional panel is to be provided in the ship's receiving switchboard (in general a section of the main switchboard).

**3.4.2** (1/7/2009)

Where parallel operation of the HV-shore supply and ship sources of electrical power for load transfer is possible, necessary instruments and synchronising devices are to be provided.

**3.4.3** (1/7/2009)

The shore connection circuit breaker is to be suitable for short time parallel operation and is to be an automatic circuit-breaker.

**3.5 Instrumentation**

**3.5.1** (1/7/2009)

When parallel operation for load transfer is implemented, the following instruments are to be available:

- two voltmeters,
- two frequency meters,
- one ammeter (with an ammeter switch to read the current in each phase), or an ammeter in each phase,
- phase sequence indicator or lamps, and
- one synchronising device.

Means are to be provided to ensure that power supply can be connected to other live parts only when synchronised.

**3.5.2** (1/7/2009)

When transfer of supply from ship to shore and vice-versa is made passing through blackout condition, the following instruments are to be available:

- two voltmeters,
- two frequency meters,
- one ammeter (with an ammeter switch to read the current in each phase), or an ammeter in each phase,
- phase sequence indicator or lamps.

**3.6 Protection**

**3.6.1** (1/7/2009)

The following alarms and circuit-breaker trips are to be implemented in the event of:

- short-circuit: tripping with alarm,
- overcurrent: in two steps - alarm, and trip with alarm,
- earth fault: alarm (tripping if required by the type of distribution system used),
- over-under voltage: in two steps - alarm, and trip with alarm,
- over-under frequency: in two steps - alarm, and trip with alarm,
- reverse power: tripping with alarm,
- overcurrent (directional overcurrent protection): tripping with alarm, and
- wrong phase sequence: protection with alarm and interlock.

**3.6.2** (1/7/2009)

At least the following protective devices, or equivalent protective devices, are to be provided to satisfy the requirements of [3.6.1] (see Note 1):

- synchronising device (25)
- undervoltage (27)
- directional power (reverse power) (32)
- phase sequence voltage (47)
- overload (49)
- instantaneous overcurrent (50)
- overcurrent (51)
- earth fault (51G)
- overvoltage (59)
- directional overcurrent (67)
- frequency (under and over) (81)

Note 1: ANSI standard device designation numbers are shown in brackets.

**3.6.3** (1/1/2022)

Load shedding of unessential consumers and restoration of ship power is to be considered where these measures could prevent complete power loss.

**3.7 Shore connection circuit-breaker**

**3.7.1** (1/1/2022)

Interlocks are to be provided to ensure that the shore connection circuit-breakers cannot be closed when:

- one of the earthing switches is closed (shoreside/shipside),
- the safety circuit is not established,
- the emergency shutdown system is activated,
- failure that would affect the safety of the connection is detected in ship or shore control, alarm or safety system
- the data communication link between shore and ship is not operational (where applicable),
- the high voltage supply is not present,
- equipotential bonding is not established, if applicable (see [2.2.4]),
- an earth fault on ship distribution system is detected.



### 3.8 Communication

#### 3.8.1 (1/7/2009)

An independent means of voice communication is to be provided between the ship and the shore.

### 3.9 HVSC behaviour in case of failure

#### 3.9.1 (1/7/2009)

If any failure occurs on the HVSC supply, all shore connection circuit-breakers are to automatically open.

Failures include loss of HV power and disconnection (including activation of emergency shutdown or electrical system protective device activation).

#### 3.9.2 (1/7/2009)

An alarm is to be given at the ship's manned station during HVSC system operation to indicate activation of the automatic circuit-breaker opening required in [3.9.1].

The alarm is to indicate the failure that caused the activation.

### 3.10 Load transfer via blackout

#### 3.10.1 (1/7/2009)

When load transfer is via blackout, interlocking means are to be provided to ensure that the shore supply can only be connected to a dead switchboard.

#### 3.10.2 (1/7/2009)

The simultaneous connection of an HVSC and a ship source of electrical power to the same dead section of the ship's electrical system is to be prevented.

#### 3.10.3 (1/7/2009)

The interlocking system is to be fault tolerant, i.e. also in the event of a single failure, improper connection is not to be possible.

### 3.11 Load transfer via temporary parallel operation

#### 3.11.1 (1/7/2009)

When parallel operation for load transfer is foreseen, loads are to be transferred between the HV shore supply and ship source(s) of electrical power after their connection in parallel.

#### 3.11.2 (1/7/2009)

The load transfer is to be completed in as short a time as practicable without causing machinery or equipment failure or intervention of protective devices and this time is to be used as the basis for defining the transfer time limit.

#### 3.11.3 (1/7/2009)

When the HVSC system is not connected, systems or functions used for paralleling or controlling the shore connection load transfer are not to affect the ship's electrical system.

#### 3.11.4 (1/1/2022)

When the defined transfer time limit for transferring of load between HV shore supply and ship source(s) of electrical power has elapsed, one of the sources is to be automatically disconnected and an alarm is to be given at the ship's manned station during HVSC system operation.

#### 3.11.5 (1/7/2009)

When load reductions are required to transfer load, this is not to result in the loss of essential or emergency services.

## 4 Ship to shore connection

### 4.1 Standardisation

#### 4.1.1 (1/7/2009)

Standardised HVSC systems, including cables and their accessories, socket-outlets, data and communication links between ship and shore and earthing, are to be used.

### 4.2 Cable installation

#### 4.2.1 (1/7/2009)

The ship to shore connection cable installation and operation are to be arranged to provide adequate movement compensation, cable guidance, anchoring and positioning of the cable during normal planned ship to shore connection conditions.

#### 4.2.2 (1/1/2022)

Ship to shore connection cable extension is not to be permitted.

### 4.3 Connectors

#### 4.3.1 (1/1/2022)

Connectors are to comply with IEC 62613-1 and the following.

#### 4.3.2 (1/1/2022)

The shore-side of the connection cable is to be fitted with plug(s). Cable connections may be permanently connected on shore to suitable terminations.

#### 4.3.3 (1/7/2009)

The shipside of the connection cable is to be fitted with connector(s). Cable connections may be permanently connected on board to suitable terminations.

#### 4.3.4 (1/7/2009)

Socket-outlets and inlets are to be interlocked with the earth switch so that plugs or connectors cannot be inserted or withdrawn without the earthing switch in closed position.

#### 4.3.5 (1/1/2022)

Handling of connectors are to be possible only when the associated earthing switch is closed.

#### 4.3.6 (1/7/2009)

The earthing contacts are to make contact before the live contact pins do when inserting a plug.

#### 4.3.7 (1/1/2022)

Each connector is to be fitted with pilot contacts to ensure continuity verification of the safety loop.

#### 4.3.8 (1/7/2009)

Contact sequence is to be the following:

- a) connection
  - earth contact,
  - power contacts, and
  - pilot contacts;
- b) disconnection
  - pilot contacts

- power contacts, and
- earth contact.

**4.3.9** (1/7/2009)

Each plug and socket-outlet is to have a permanent, durable and readable nameplate with the following information:

- Manufacturer's name and trademark,
- type designation, and
- applicable rated values.

The nameplates are to be readable during normal service.

**4.3.10** (1/1/2022)

Support arrangements are to be foreseen so that the weight of connected cable is not borne by any plug or ship connector termination or connection.

**4.3.11** (1/1/2022)

Pilot contact connections are to open before the necessary degree of protection is no longer achieved during the removal of an HV plug or connector. Pilot contacts are to be part of the safety circuit.

**4.3.12** (1/1/2022)

Interlocking with earthing switches is to be arranged to ensure that the HV power contacts remain earthed until:

- all connections are made,
- no emergency stop is activated,
- the communication link is operational,
- self-monitoring properties of ship or shore alarm, control and safety systems detect that no failure would affect safe connections, and
- the permission from ship and shore is activated.

Interlocking are to be hardwired.

**4.3.13** (1/7/2009)

The current carrying capacity of the earth contact is to be at least equal to the rated current of the other main contacts.

**4.4 Cables**

**4.4.1** (1/7/2009)

Cables are to be at least of a flame-retardant type in accordance with the requirements given in IEC 60332-1-2.

**4.4.2** (1/7/2009)

The outer sheath is to be oil-resistant, resistant to sea air, sea water, solar radiation (UV) and non-hygroscopic.

**4.4.3** (1/7/2009)

The insulation temperature class is to be at least 85°C.

**4.5 Protection**

**4.5.1** (1/7/2009)

If unbalanced damaging (above the rated cable current) current among multiple phase conductors (parallel power cables and connectors) occurs, the ship and shore HV circuit-breakers are to trip opening all insulated poles.

**4.5.2** (1/1/2022)

Protective devices to satisfy the requirement of [4.5.1] are to be installed ashore to isolate the connection in the event of damaging unbalanced detection.

**4.6 Data communication**

**4.6.1** (1/7/2009)

At least the following data are to be communicated at the ship's manned station during HVSC system operation:

- shore transformer high temperature alarm,
- HV shore supply circuit-breaker protection activation,
- permission to operate HV circuit-breakers for HV ship to shore connection,
- alarm given by self-monitoring facilities of the ship or shore alarm, control or safety systems, when an error that would affect safe connection is detected,
- emergency stop activation,
- where provided, shore control functions,
- emergency disconnection of the shore supply.

**4.7 Storage**

**4.7.1** (1/7/2009)

When not in use, shipboard equipment is to be stored in dry spaces in such a way that it does not present a hazard during normal ship operation.

**4.7.2** (1/7/2009)

Parts dismantled after use of the communication link are to be provided with stowage arrangements.

**4.7.3** (1/7/2009)

When stored, plugs, socket-outlets, inlets and connectors are to maintain their IP ratings.

**4.7.4** (1/7/2009)

Temporary coverings are not considered to satisfy [4.7.1], [4.7.2] or [4.7.3].

**4.8 Equipotential bond monitoring**

**4.8.1** (1/1/2022)

The equipotential bond monitoring device, where provided, is to be installed either ashore or onboard where the cable management system is installed. Equipotential bond monitoring termination device, where provided, is to be installed on the other side.

**5 Testing**

**5.1 Rule application**

**5.1.1** (1/7/2009)

Before a new installation or any alteration or addition to an existing installation is put into service, the electrical equipment is to be tested in accordance with the following to the satisfaction of the Surveyor in charge.

**5.2 Type approved components**

**5.2.1** (1/1/2022)

Plugs, connectors and socket-outlets, in addition to the components listed in Pt C, Ch 2, Sec 15, [2.1.1], are to be type tested or type approved or provided with manufacturer's statement of conformity to the applicable IEC product standard.

**5.2.2** (1/7/2009)

Case-by-case approval based on submission of adequate documentation and execution of tests may also be granted at the discretion of the Society.

**5.3 Component testing****5.3.1** (1/7/2009)

HV system components are to be type and routine tested according to the relevant applicable requirements.

**5.3.2** (1/7/2009)

Tests are to be carried out to demonstrate that the electrical system and its alarm, control and safety systems have been correctly installed and are in good working order.

**5.4 Initial tests of shipside installation for HVSC-NB additional class notation****5.4.1** (1/5/2022)

Tests are to be carried out on the ship's system, including alarm, control and safety equipment, according to a prescriptive test program to be agreed with the Society, to verify that the shipside installation complies with the requirements of this Section.

**5.4.2** (1/7/2009)

Tests are to be carried out in the presence of a Surveyor of the Society after completion of the installation.

**5.4.3** (1/1/2022)

The following tests are to be carried out:

- visual inspection,
- HV test,
- insulation resistance measurement,
- ship-side bonding connection resistance measurement,
- functional tests including correct settings of the protection devices,
- functional tests of the interlocking system,
- functional tests of the control equipment,
- earth fault monitoring test,
- phase sequence test,
- functional tests of the cable management system, where applicable,
- integration tests to demonstrate that the shipside installations such as the power management system, integrated alarm, control and safety systems, etc. work properly.

**5.5 Ship Shore Integration tests for HVSC additional class notation****5.5.1** (1/5/2022)

A preliminary assessment in accordance with [1.1.4] and the following tests are to be carried out for the issuance of the HVSC addition class notation:

- visual inspection,
- insulation resistance measurement,
- measurement of the earthing resistance,
- functional tests of the protection devices,
- functional tests of the interlocking system,
- functional tests of the control equipment,
- load functional test at the ship required electric load,
- earth fault monitoring test,
- phase sequence test,
- equipotential bond monitoring test, if applicable (see [2.2.4]),
- phase sequence test,
- functional tests of the cable management system, where applicable.

The integration tests are to be managed by a single designated party and are to be performed in accordance with a defined procedure identifying the roles, responsibilities and requirements of all parties involved, and have to demonstrate:

- that the ship-side installations such as the power management system, integrated alarm, control and safety systems, etc. work properly
- that the shore and ship-side installations work properly eg: communication and relevant safeties.

Evidence that shore side installation has been satisfactory tested before the above-mentioned integration tests, prior to connection with shipside, is to be made available to attending surveyor.

The test program is to be agreed with the Society and is to be used to identify any procedural or engineering problems to be solved.

Additional and/or alternative requirements, if any, of:

- national administrations
- authorities within whose jurisdiction the ship is intended to operate
- owners of shore supply or distribution system
- authorities responsible for a shore supply or distribution system

are to be kept into consideration.

**SECTION 16****HELICOPTER FACILITIES (HELIDECK)****1 General****1.1 Application****1.1.1 (1/7/2010)**

This Section provides the criteria for the assignment of the additional class notations **HELIDECK** and **HELIDECK-H**, in accordance with Pt A, Ch 1, Sec 2, [6.14.19], to ships fitted with helicopter facilities (i.e. platforms specifically built for the landing of helicopters or areas of open decks intended for the same purpose).

**1.1.2 (1/7/2010)**

The requirements set out in this Section are applied by the Society for the purposes of the class notations in [1.1.1]. Compliance with these requirements does not absolve the Interested Parties from obligations regarding different and/or

more stringent regulations issued by the flag Administration, international organisations or other concerned Parties, if applicable.

**1.1.3 (1/7/2010)**

Notwithstanding the requirements of this Section, the notation **HELIDECK** may also be assigned to ships fitted with helicopter facilities in compliance with relevant national or international regulations. In this case, a specific annotation concerning the applied regulations will be introduced in the Certificate of Classification.

**1.2 Documents to be submitted****1.2.1 (1/7/2010)**

The documents listed in Tab 1 are to be submitted to the Society.

**Table 1 : Documents to be submitted (1/7/2010)**

No.	I/A (1)	Document (2)
1	I	General arrangement plan
2	I	Main characteristics of helicopter intended to use the helideck (main dimensions and weight)
3	A	General plan showing the markings to be fitted on the helideck
4	A	Structural plans of the helideck also showing the connection of the helideck with the unit's hull
5	A	Diagram of the fuel supply system
6	A	Structural fire protection, showing the purpose of the various spaces, adjacent helideck & helideck facilities and the fire rating of relevant bulkheads and decks
7	A	Natural and mechanical ventilation systems of helideck facilities (including ventilation systems serving hazardous spaces) showing: <ul style="list-style-type: none"> <li>• position of vent inlets and outlets;</li> <li>• penetrations on "A" class divisions;</li> <li>• location of dampers;</li> <li>• means of closing;</li> <li>• arrangements of air conditioning rooms;</li> <li>• location of fan controls;</li> <li>• air changes per hour (where requirements for air changes per hour are set)</li> </ul>
8	A	Automatic fire detection systems

(1) A : to be submitted for approval, in four copies

I : to be submitted for information, in duplicate.

(2) Plans are to be schematic and functional and to contain all information necessary for their correct interpretation and verification, such as:

- structural scantling
- service pressures
- capacity and head of pumps and compressors, if any
- materials and dimensions of piping and associated fittings
- volumes of protected spaces, for gas and foam fire-extinguishing systems
- surface areas of protected zones for automatic sprinkler and pressure water-spraying, low expansion foam and powder fire-extinguishing systems

All or part of the information may be provided, instead of on the above plans, in suitable operating manuals or in specifications of the systems.

No.	I/A (1)	Document (2)
9	A	Fire pumps and fire main including pump head and capacity, hydrant and hose locations
10	A	Arrangement of fixed fire-extinguishing systems
11	A	Fire-fighting equipment and firemen's outfits (or fire control plans)
12	A	Electrical diagram of the fixed gas fire-extinguishing systems
13	A	Plan of hazardous areas relevant to hangar and refuelling installations
14	A	Documents giving details of types of cables and safety characteristics of the equipment installed in the hazardous areas mentioned in 13 above

(1) A : to be submitted for approval, in four copies  
I : to be submitted for information, in duplicate.

(2) Plans are to be schematic and functional and to contain all information necessary for their correct interpretation and verification, such as:

- structural scantling
- service pressures
- capacity and head of pumps and compressors, if any
- materials and dimensions of piping and associated fittings
- volumes of protected spaces, for gas and foam fire-extinguishing systems
- surface areas of protected zones for automatic sprinkler and pressure water-spraying, low expansion foam and powder fire-extinguishing systems

All or part of the information may be provided, instead of on the above plans, in suitable operating manuals or in specifications of the systems.

## 2 Helideck lay-out

### 2.1 General

#### 2.1.1 (1/7/2010)

The construction of the helidecks is to be of steel or other equivalent metallic materials, i.e. any non-combustible metallic material which, by itself or due to insulation provided (e.g. aluminium alloy with appropriate insulation), has structural and integrity properties equivalent to steel at the end of the applicable exposure to the standard fire test (see Note 1). Where the Society permits aluminium or other low melting point metal construction, items [4.2.1] a) to c) are also to be taken into account.

Note 1: Refer to the "International Code for Application of Fire Test Procedures" (FTP Code), as adopted by the Maritime Safety Committee of IMO by Resolution MSC.61 (67), as may be amended by IMO.

### 2.2 Definitions

#### 2.2.1 (1/7/2010)

- "Helicopter landing area" means an area on a ship designed for emergency landing of helicopters.
- "Diameter (d)" means the overall length of the helicopter with the rotors turning. The maximum value of "d" will depend on the type and size of the helicopter. This is to be agreed by the Society taking into account the particulars of the ship and its area of operation.

## 2.3 Landing area

### 2.3.1 Positioning of landing area (1/7/2010)

Helicopter landing areas are to be located on a weather deck or on a platform permanently connected to the hull structure. The landing areas are to consist of an outer manoeuvring zone and a clear zone. Whenever possible, the clear zone is to be close to the ship's side.

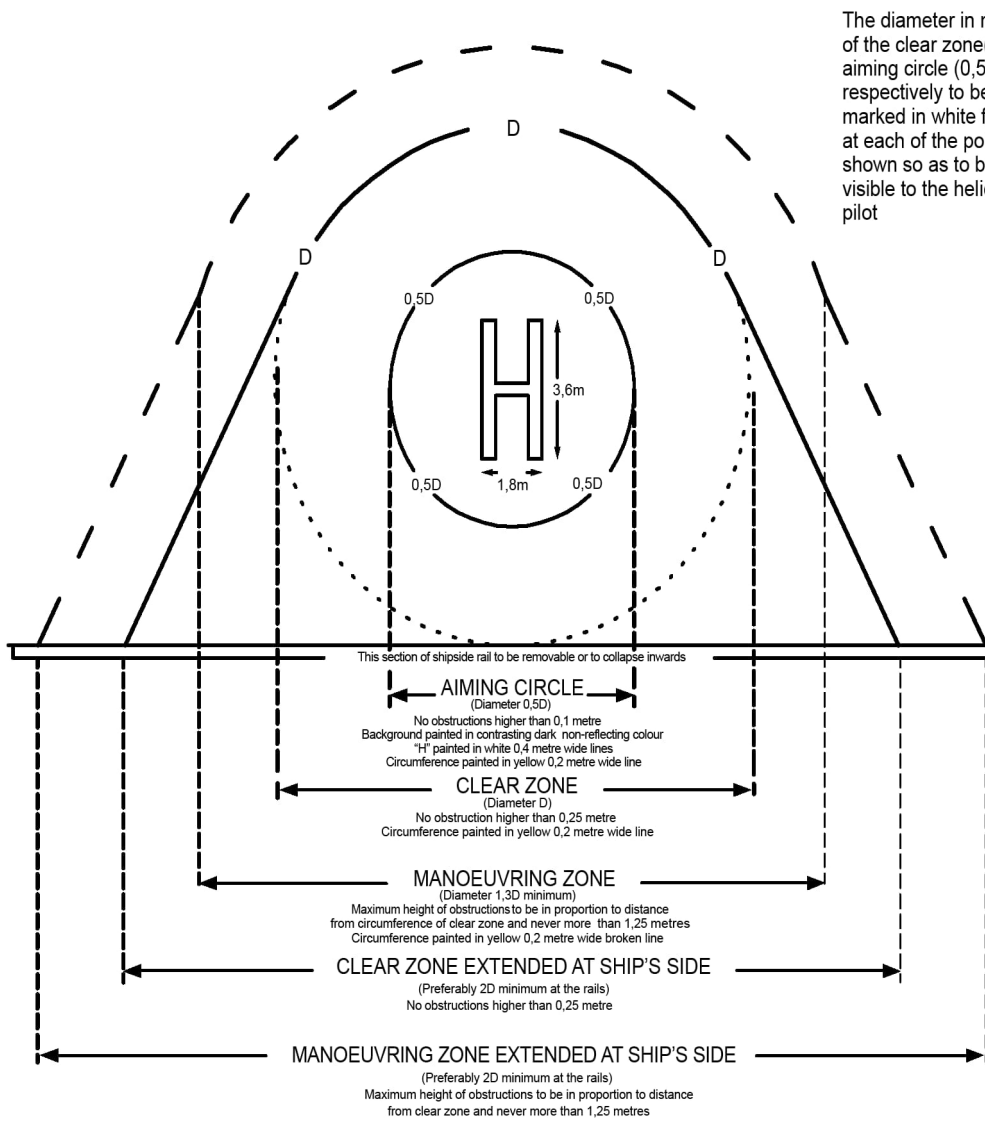
### 2.3.2 Landing area at ship's side (1/7/2010)

The landing area is to be as large as possible and set out to provide safe access for helicopters from the ship's side. Due account must be taken of possible helicopter slippage and wind and ship movement. Where the boundary of the clear zone is close to or in line with the ship's side, and where the height of fixed obstructions so permits (see item [2.3.8]), helicopter safety is to be improved by extending the clear and manoeuvring zones to the ship's side symmetrically, thereby widening the approach to the landing area (see Fig 1).

### 2.3.3 Landing area without unobstructed access from ship's side (1/7/2010)

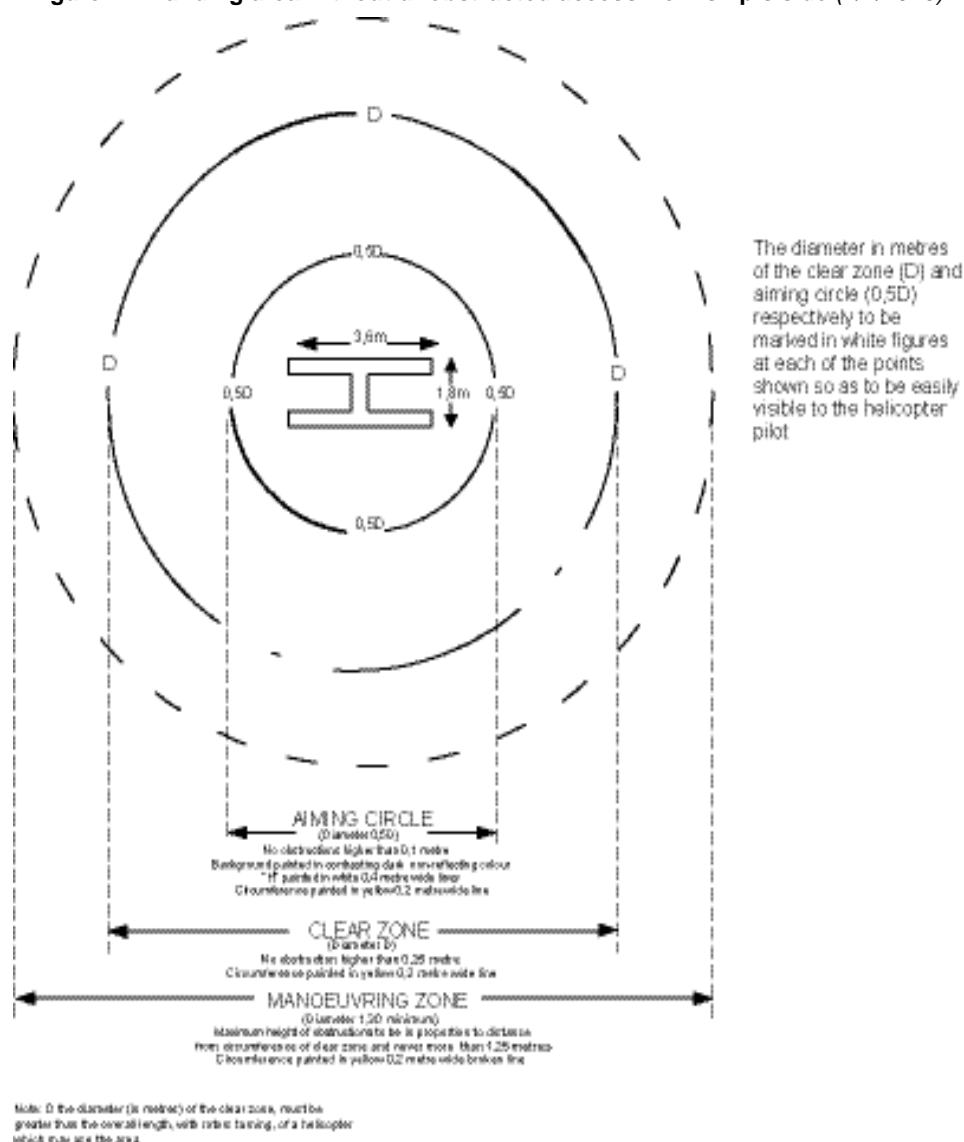
Where it is not possible to provide an operating area with clear access from the ship's side, the landing area is to be set out as shown in Fig 2 and, if practicable, placed on the ship's centreline.

Figure 1 : Landing area at the ship's side (1/7/2010)



The diameter in  $r$  of the clear zone aiming circle (0,5 respectively to be marked in white  $f$  at each of the poi shown so as to be visible to the heli pilot

Figure 2 : Landing area without unobstructed access from ship's side (1/7/2010)



### 2.3.4 Dimension of the landing area (1/7/2010)

In establishing a landing area, it is essential to ensure a safe correlation between:

- the dimensions of the aiming circle, clear zone and manoeuvring zone and the maximum permitted height of obstructions in these zones; and
- the sizes of helicopters expected to use the facility.

The dimensions of the landing area are to be in proportion to the diameter of the clear zone, as illustrated in Fig 1 and Fig 2 (see [2.3.6]).

### 2.3.5 Aiming circle (touchdown zone) (1/7/2010)

The aiming circle is an area concentric to the centre of the clear zone and has a diameter half that of the clear zone itself. The circle is to accommodate with safety the landing gear of helicopters for which it is intended and, if possible, be completely obstruction-free. If there are unavoidable obstructions, they are to have rounded edges capable of being traversed without damaging the landing gear of a helicopter, and are to be no higher than 0,1 m.

The aiming circle is to be completely covered with a matt anti-slip surface painted in a dark non-reflecting colour which contrasts with the other deck surfaces. Its circumference is to be marked with a yellow line 0,2 m wide, with the diameter in metres of the aiming circle clearly indicated in white figures at four points in the circumference line as shown in Fig 1 and Fig 2.

The letter 'H' is to be painted at the centre of the aiming circle in 0,4 m wide white lines forming a letter of dimensions 3,6 x 1,8 m.

### 2.3.6 Clear zone (1/7/2010)

The diameter of the clear zone will depend upon the available landing area. The clear zone is however to be as large as practicable recognizing that its diameter D is to be greater than the overall length, with rotors turning, of a helicopter able to use the landing area (d). Where the landing area is at the ship's side safe helicopter access will be enhanced by widening, where possible, the boundaries of the obstacle free clear zone at the ship's side to a dimension of at least 1,5D (see Fig 1).

The circumference of the clear zone is to be marked by a yellow line of 0,2 m width, with the diameter D in metres indicated in white figures at points in the circumference line as shown in Fig 1 and Fig 2.

There are to be no fixed obstructions in the clear zone higher than 0,25 m.

**2.3.7 Manoeuvring zone (1/7/2010)**

The maneuvering zone of the landing area extends the area in which a helicopter may maneuver with safety by enlarging, to a diameter of at least 1,3D, the area over which the rotors of the helicopter may overhang without danger from high obstructions. When the landing area is at the ship's side, safe helicopter access will be enhanced by widening, where possible, the boundaries of the obstruction-free maneuvering zone at the ship's side to a dimension of at least 2D (see Fig 1).

If it is impossible to remove all obstructions from the manoeuvring zone, a graduated increase in the permitted height of obstructions, from 0,25 m at the circumference of the clear zone to a maximum of 1,25 m at the circumference of the manoeuvring zone, is acceptable. However, such height above 0,25 m is not to exceed a ratio of one to two in relation to the horizontal distance of the obstruction from the edge of the clear zone (see Fig 3). So, for example, an obstruction of 1 m in height (0,75 m more than the maximum obstruction height in the clear zone) is to be at least 1,5 m outside the circumference of the clear zone. All obstructions in the manoeuvring zone are to be clearly marked in contrasting colours.

To assist the helicopter pilot in his positioning, the circumference of the manoeuvring zone is to be indicated by a broken yellow line of 0,2 m width (see Fig 1 and Fig 2).

**2.3.8 Use of landing area for other purposes (1/7/2010)**

It is considered that helicopter landing areas may be used for other purposes in normal circumstances. In the event of need, it is to be possible to clear this area readily.

**2.3.9 Night operations: Lighting (1/7/2010)**

The following general remarks apply in all cases:

- a) lighting is to be arranged so as to illuminate the operating area and is not to be directed towards the helicopter; and
- b) a wind pennant or flag is to be illuminated.

For a helideck located on an ad hoc platform, a safety net is to be provided at the sides of the platform. The requirements of this item [2.3.9] may be not met if the position and arrangement of the helicopter platform facilities are such that, in the opinion of the Society, they provide an equivalent standard of safety.

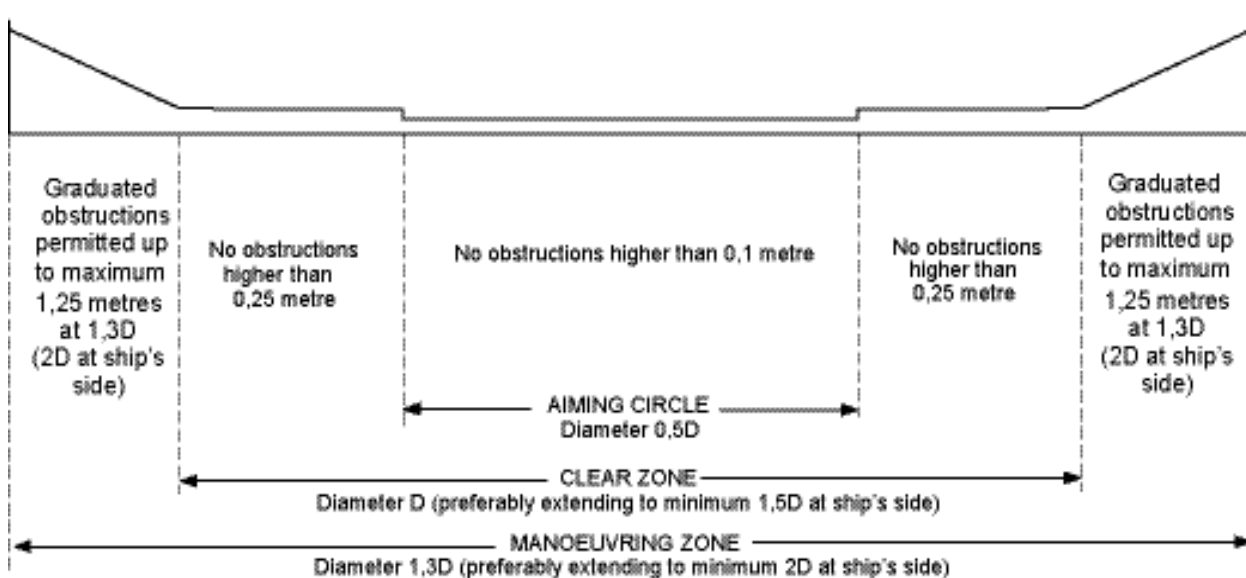
**2.3.10 Drainage system (1/7/2010)**

Gutter-ways of adequate height and a drainage system are to be provided on the periphery of the helideck.

Drainage facilities are to be constructed of steel, lead directly overboard independent of any other system and are to be designed so that drainage does not fall onto any part of the ship.

The requirements of this item [2.3.10] may be not met if the position and arrangement of the helicopter facilities are such that, in the opinion of the Society, they provide an equivalent standard of safety.

**Figure 3 : Landing area - permitted height of obstructions (elevation) (1/7/2010)**





### 3 Structural design and scantling

#### 3.1 General and symbols

##### 3.1.1 General (1/7/2010)

Local deck strengthening is to be fitted at the connection of diagonals and pillars supporting the platform where an ad hoc platform is fitted for the helideck.

##### 3.1.2 Symbols (1/7/2010)

$W_H$	: Maximum weight of the helicopter, in t
$g$	: Gravity acceleration, in $m/s^2$
$R_y$	: Minimum yield stress, in $N/mm^2$ , of the material, to be taken equal to $235/k N/mm^2$ , unless otherwise specified
$k$	: material factor for steel, defined in Pt B, Ch 4, Sec 1, [2.3].

#### 3.2 Design loads

##### 3.2.1 Landing area located on a weather deck (1/7/2010)

The following loads are to be considered for the scantlings of the helicopter deck:

- landing load defined in [3.4],
- garage load, if any, defined in [3.5],
- loads due to ship accelerations and wind defined in [3.6].

##### 3.2.2 Landing area located on a platform (1/7/2010)

The loads defined in [3.2.1], and in addition the sea pressure defined in [3.3], are to be considered for the scantlings of the helicopter deck.

##### 3.2.3 Helicopter having landing devices other than wheels (1/7/2010)

In the case of a deck or a platform intended for the landing of helicopters having landing devices other than wheels (e.g. skates), the landing load, the emergency landing load and the garage load, if any, will be examined by the Society on a case-by-case basis.

#### 3.3 Sea pressure

##### 3.3.1 (1/7/2010)

The sea pressure acting on a landing platform is to be obtained according to Pt B, Ch 5, Sec 5, [2.1.2].

#### 3.4 Landing load

##### 3.4.1 (1/7/2010)

The landing load transmitted through one tyre to the deck or the platform is to be obtained, in kN, from the following formula:

$$F_{CR} = 0,75gW_H$$

##### 3.4.2 (1/7/2010)

Where the upper deck of a superstructure or deckhouse is used as a helicopter deck and the spaces below are quarters, the bridge, control room or other normally manned service spaces, the value of the landing load defined in [3.4.1] is to be multiplied by 1,15.

#### 3.5 Garage load

##### 3.5.1 (1/7/2010)

Where a garage zone is fitted in addition to the landing area, the still water and inertial forces transmitted through the tyres to the deck or the platform in the garage zone are to be obtained, in kN, as specified in Pt B, Ch 5, Sec 6, [6.1.2], where  $M$  is to be taken equal to  $0,5 W_H$ .

#### 3.6 Forces due to ship accelerations and wind

##### 3.6.1 (1/7/2010)

The still water and inertial forces applied to the deck or the platform are to be determined on the basis of the forces obtained, in kN, as specified in Tab 2.

#### 3.7 Net scantling

##### 3.7.1 (1/7/2010)

As specified in Pt B, Ch 4, Sec 2, [1], all scantlings referred to in this Section are net, i.e. they do not include any margin for corrosion.

The gross scantlings are obtained as specified in Pt B, Ch 4, Sec 2, [1].

#### 3.8 Plating

##### 3.8.1 Load model for landing area located on a weather deck (1/7/2010)

The following loads transmitted by tyre prints are to be considered:

- landing load, as defined in [3.4],
- garage load, if any, as defined in [3.5].

##### 3.8.2 Load model for landing area located on a platform (1/7/2010)

The following loads are to be considered independently:

- sea pressure, as defined in [3.3],
- loads transmitted by tyre prints,
- landing load, as defined in [3.4],
- garage load, if any, as defined in [3.5].

##### 3.8.3 Plating subjected to sea pressure (1/7/2010)

The net thickness of the landing area plating subjected to sea pressure is to be not less than that obtained from the formulae in Pt B, Ch 7, Sec 1, [3].

##### 3.8.4 Plating subjected to landing load or garage load (1/7/2010)

The net thickness of the landing area plating subjected to landing load or garage load, if any, transmitted by tyre prints, is to be not less than that obtained from the formulae in Pt B, Ch 7, Sec 1, [4.3], considering the wheeled load as being calculated according to [3.8.1] or [3.8.2], as applicable.

Where the print area is not specified by the Designer, a 300x300 mm print area is to be taken into account.

**Table 2 : Still water and inertial forces (1/7/2010)**

Ship condition	Load case	Still water force $F_s$ and inertial force $F_w$ , in kN
Still water condition		$F_s = (W_H + W_p)g$
Upright condition	"a"	No inertial force
	"b"	$F_{w,x} = (W_H + W_p) a_{x1} + 1,2 A_{HX}$ in x direction $F_{w,z} = (W_H + W_p) a_{z1}$ in z direction
Inclined condition (negative roll angle)	"c"	$F_{w,y} = C_{FA}(W_H + W_p) a_{y2} + 1,2 A_{HY}$ in y direction
	"d"	$F_{w,z} = C_{FA}(W_H + W_p) a_{z2}$ in z direction
<b>Note 1:</b>		
<p><math>W_p</math> : structural weight of the platform, in t, to be evenly distributed, and to be taken not less than the value obtained from the following formula: <math>W_p = 0,2 A_H</math></p> <p><math>A_H</math> : area, in <math>m^2</math>, to be obtained projecting on A horizontal plane parallel to the summer load waterline the entire landing area considering also possible helideck supporting structures outside the landing area</p> <p><math>a_{x1}, a_{z1}</math> : accelerations, in <math>m/s^2</math>, determined at the helicopter centre of gravity for the upright ship condition, and defined in Ch 5, Sec 3, [3.4]</p> <p><math>a_{y2}, a_{z2}</math> : accelerations, in <math>m/s^2</math>, determined at the helicopter centre of gravity for the inclined ship condition, and defined in Ch 5, Sec 3, [3.4]</p> <p><math>A_{HX}</math> : area, in <math>m^2</math>, to be obtained projecting on a transversal plane perpendicular to the summer load waterline the helideck supporting structures (including the helideck platform)</p> <p><math>A_{HY}</math> : area, in <math>m^2</math>, to be obtained projecting on a longitudinal plane parallel to the centreline plane of the ship the helideck supporting structures (including the helideck platform)</p> <p><math>C_{FA}</math> : Combination factor, to be taken equal to:</p> <ul style="list-style-type: none"> <li>• <math>C_{FA} = 0,7</math> for load case "c"</li> <li>• <math>C_{FA} = 1,0</math> for load case "d"</li> </ul>		

### 3.9 Ordinary stiffeners

#### 3.9.1 Load model for landing area located on a weather deck (1/7/2010)

The following loads are to be considered independently:

- landing load defined in [3.4],
- garage load, if any, defined in [3.5],
- loads due to ship accelerations and wind defined in [3.6].

#### 3.9.2 Load model for landing area located on a platform (1/7/2010)

The following loads are to be considered independently:

- sea pressure, as defined in [3.3],
- loads transmitted by tyre prints,
- landing load defined in [3.4],
- garage load, if any, as defined in [3.5],
- loads due to ship accelerations and wind defined in [3.6].

#### 3.9.3 Normal and shear stresses (1/7/2010)

Normal and shear stresses induced by loads and pressures in an ordinary stiffener are to be obtained according to:

- Pt B, Ch 7, Sec 2, [3.4] for an ordinary stiffener subjected to sea pressure,
- Pt B, Ch 7, Sec 2, [3.5] for an ordinary stiffener subjected to loads transmitted by tyre prints.

#### 3.9.4 Checking criteria (1/7/2010)

It is to be checked that the normal stress  $\sigma$  and the shear stress  $\tau$  calculated according to [3.9.3], are in compliance with the following formulae:

$$\frac{R_y}{\gamma_R \gamma_m} \geq \sigma$$

$$0,5 \frac{R_y}{\gamma_R \gamma_m} \geq \tau$$

where:

- $\gamma_m$  : partial safety factor covering uncertainties on the material, to be taken equal to 1,02
- $\gamma_R$  : partial safety factor covering uncertainties on the resistance:
  - $\gamma_R = 1,3$  for landing area located above accommodation spaces,
  - $\gamma_R = 1,05$  for landing area located outside a zone covering accommodation spaces,
  - $\gamma_R = 1,0$  for emergency condition.

### 3.10 Primary supporting members

#### 3.10.1 Load model for landing area located on a weather deck (1/7/2010)

The following loads are to be considered independently:

- loads transmitted by tyre prints,
- landing load defined in [3.4],

- garage load, if any, defined in [3.5],
- loads due to ship accelerations and wind defined in [3.6].

### 3.10.2 Load model for landing area located on a platform (1/7/2010)

The following loads are to be considered independently:

- sea pressure, as defined in [3.3],
- loads transmitted by tyre prints,
- landing load defined in [3.4],
- garage load, if any, defined in [3.5],
- loads due to ship accelerations and wind defined in [3.6].

### 3.10.3 Normal and shear stresses (1/7/2010)

Normal and shear stresses induced by loads and pressures in a primary supporting member are to be obtained according to Pt B, Ch 7, App 1, [5], considering:

- $\sigma = \max(\sigma_1, \sigma_2)$  and  $\tau = \tau_{12}$ , for analyses based on finite element models,
- $\sigma = \sigma_1$  and  $\tau = \tau_{12}$ , for analyses based on beam models.

### 3.10.4 Checking criteria (1/7/2010)

It is to be checked that the normal stress  $\sigma$  and the shear stress  $\tau$  calculated according to [3.9.3], are in compliance with the following formulae:

$$\frac{R_y}{\gamma_R \gamma_m} \geq \sigma$$

$$0,5 \frac{R_y}{\gamma_R \gamma_m} \geq \tau$$

where:

- $\gamma_m$  : partial safety factor covering uncertainties on the material, to be taken equal to 1,02
- $\gamma_R$  : partial safety factor covering uncertainties on the resistance:
- $\gamma_R = 1,3$  for landing area located above accommodation spaces,
  - $\gamma_R = 1,05$  for landing area located outside a zone covering accommodation spaces,
  - $\gamma_R = 1,0$  for emergency condition.

## 4 Specific requirements for the assignment of the Helideck-H notation

### 4.1 Refuelling and hangar facilities

#### 4.1.1 Storage of fuel (1/7/2010)

- a) A designated area is to be provided for the storage of fuel tanks which is to be:
- as remote as is practicable from accommodation spaces, escape routes and embarkation stations; and
  - isolated from areas containing a source of vapour ignition.

- b) The fuel storage area is to be provided with arrangements whereby fuel spillage may be collected and drained to a safe location.
- c) "NO SMOKING" signs are to be displayed at appropriate locations.
- d) Tanks and associated equipment are to be protected against physical damage and from a fire in an adjacent space or area.
- e) Where portable fuel storage tanks are used, special attention is to be given to:
- design of the tank for its intended purpose;
  - mounting and securing arrangements;
  - electric bonding; and;
  - inspection procedures.
- f) Storage tank fuel pumps are to be provided with means which permit shutdown from a safe remote location in the event of a fire. Where a gravity fuelling system is installed, equivalent closing arrangements are to be provided to isolate the fuel source.
- g) The fuel pumping unit is to be connected to one tank at a time. The piping between the tank and the pumping unit is to be of steel or equivalent material, as short as possible, and protected against damage.
- h) Electrical fuel pumping units and associated control equipment are to be of a type suitable for the location and potential hazards.
- i) Fuel pumping units are to incorporate a device which will prevent overpressurisation of the delivery or filling hose.
- j) Equipment used in refuelling operations is to be electrically bonded.
- k) Electrical equipment and wiring in an enclosed hangar or enclosed spaces containing refuelling installations are to comply with the following:
- 1) electrical equipment and wiring are to be of a type suitable for use in an explosive petrol and air mixture (see Note 1);
  - 2) electrical equipment and wiring, if installed in an exhaust ventilation duct, are to be of a type approved for use in explosive petrol and air mixtures and the outlet from any exhaust duct is to be sited in a safe position, having regard to other possible sources of ignition; and
  - 3) other equipment which may constitute a source of ignition of flammable vapours is not permitted.

Note 1: Refer to the recommendations of the International Electrotechnical Commission, in particular publication 60079.

### 4.2 Fire protection

#### 4.2.1 Fire integrity of bulkheads and decks (1/7/2010)

- a) If the Society permits aluminium or other low melting point metal construction that is not made equivalent to steel, the following provisions in [4.2.2] and [4.2.3], as pertinent, are to be satisfied.

- b) If the platform is cantilevered over the side of the ship, after each fire on the ship or on the platform, the latter is to undergo a structural analysis to determine its suitability for further use; and
- c) if the platform is located above the ship's deckhouse or similar structure, the following conditions are to be satisfied:
  - 1) the deckhouse top and bulkheads under the platform are to have no openings;
  - 2) windows under the platform are to be provided with steel shutters; and
  - 3) after each fire on the platform or in close proximity, the platform is to undergo a structural analysis to determine its suitability for further use.
- d) If the helideck forms the deckhead of a deckhouse or superstructure, it is to be insulated to "A-60" class standard.
- e) Hangar, refuelling and maintenance facilities are to be treated as category 'A' machinery spaces with regard to structural fire protection requirements. For the determination of the structural fire protection of these spaces with respect to adjacent spaces, SOLAS regulations II-2/9.2.2.3, 9.2.2.4, 9.2.3.3 or 9.2.4.2 apply on the basis of the type of ship under consideration (i.e. passenger ship, cargo ship or tanker).

#### 4.2.2 Ventilation (1/7/2010)

- a) Enclosed hangar facilities or enclosed spaces containing refuelling installations are to be provided with mechanical ventilation complying with these requirements.
- b) The system is to be capable of:
  - providing 6 air changes per hour;
  - preventing air stratification and the formation of air pockets;
  - being controlled from a position outside the spaces served.
- c) Ventilation fans are to be of non-sparking type and are normally to be run continuously whenever helicopters are on board. Where this is impracticable, they are to be operated for a limited period daily as weather permits and in any case for a reasonable period prior to discharge, after which period the hangar facilities or enclosed spaces containing refuelling installations are to be proved gas-free. At least one portable combustible gas detecting instrument is to be carried for this purpose.
- d) Means are to be provided on the navigation bridge to indicate any loss of the required ventilating capacity.
- e) Ventilation ducts, including dampers, are to be made of steel and are to be capable of being effectively sealed for each space served.
- f) Arrangements are to be provided to permit a rapid shut-down and effective closure of the ventilation ducts and openings from outside of the space served in case of fire, taking into account the weather and sea conditions.

#### 4.2.3 Fire-fighting appliances and rescue equipment (1/7/2010)

The following fire-fighting appliances are to be provided and stored in close proximity to and near the means of access to the helideck:

- a) at least two dry powder extinguishers having a total capacity of not less than 45 kg;
- b) carbon dioxide extinguishers of a total capacity of not less than 18 kg or equivalent;
- c) a suitable foam application system consisting of monitors or foam making branch pipes capable of delivering foam to all parts of the helideck in all weather conditions in which helicopters can operate. The system is to be capable of delivering a discharge rate as required in Tab 3 for at least five minutes;
- d) a principal agent suitable for use with salt water and conforming to performance standards not inferior to those acceptable to the Society (see Note 1):
- e) at least two nozzles of an approved dual-purpose type (jet/spray) and hoses sufficient to reach any part of the helideck;
- f) two sets of fire-fighter's outfits, additional to those required elsewhere; and
- g) at least the following equipment, stored in a manner that provides for immediate use and protection from the elements:
  - adjustable wrench;
  - blanket, fire-resistant;
  - cutters, bolt 60 cm;
  - hook, grab or salving;
  - hacksaw, heavy duty complete with 6 spare blades;
  - ladder;
  - lift line 5 mm diameter x 15 m in length;
  - pliers, side cutting;
  - set of assorted screwdrivers; and
  - harness knife complete with sheath.

Note 1: Refer to the International Civil Aviation Organization Airport Services Manual, Part 1 - Rescue and Fire Fighting, Chapter 8-Extinguishing Agent Characteristics, Paragraph 8.1.5 - Foam Specifications Table 8-1, Level 'B'.

#### 4.2.4 Fire-fighting appliances for hangars, refuelling and maintenance facilities (1/7/2010)

Hangars, refuelling and maintenance facilities are to be provided with:

- a) a fixed fire-extinguishing system complying with Chapter 5, 6 or 7 of the Fire Safety System Code;
- b) a fire detection and alarm system complying with Chapter 9 of the Fire Safety System Code;
- c) one portable foam applicator unit of capacity of 20 l with a spare charge;
- d) foam-type fire extinguishers, each of at least 45 l capacity or equivalent, sufficient in number to enable foam or its equivalent to be directed onto any part of the space;

- e) a sufficient number of portable foam extinguishers or equivalent, which are to be so located that no point in the space is more than 10 m walking distance from an extinguisher and that there are at least two such extinguishers in each such space.

#### 4.2.5 Means of escape (1/7/2010)

A helideck is to be provided with both a main and an emergency means of escape and access for fire-fighting and rescue personnel. These are to be located as far apart from each other as is practicable and preferably on opposite sides of the helideck.

## 5 Specific requirements for the assignment of the Helideck notation

### 5.1 Fire protection

#### 5.1.1 (1/7/2010)

The requirements of items a) to d) of [4.2.1] apply.

### 5.2 Fire-fighting appliances and rescue equipment

#### 5.2.1 Fire-fighting equipment fitted on board (1/7/2010)

Fire-fighting equipment fitted on board may be used, to the Society's satisfaction. This equipment is to be made readily available in close proximity to the landing or winching areas during helicopter operations.

### 5.3 Means of escape

#### 5.3.1 (1/7/2010)

The requirements of item [4.2.5] apply.

**Table 3 : Foam discharge rates (1/7/2010)**

Category	Helicopter overall length	Foam solution discharge rate
H1	Less than 15 m	250
H2	At least 15 m but less than 24 m	500
H3	At least 24 m but less than 35 m	800

## SECTION 17

## FIRE PROTECTION (FIRE)

### 1 General

#### 1.1 Application

##### 1.1.1 (1/1/2020)

This Section provides the criteria for the assignment of the following additional class notations, in accordance with Pt A, Ch 1, Sec 2, [6.14.22], to passenger and cargo ships as specified in the relevant Articles:

- **FIRE-AS**, assigned to ships with accommodation and service spaces meeting the requirements in Articles [2] and [3]
- **FIRE-MS**, assigned to ships with machinery spaces meeting the requirements in Articles [2] and [4];
- **FIRE-MS (hot-spots)**, assigned to ships with machinery spaces meeting the requirements in Articles [5];
- **FIRE-CS**, assigned to ships with cargo decks and cargo spaces meeting the requirements in [1.1.2] and Articles [2] and [6]; and

- **FIRE**, assigned to ships meeting all the requirements pertinent to the assignment of the previously listed class notations as applicable to the ship type being considered.

##### 1.1.2 (1/7/2011)

Compliance with the requirements of this Section does not absolve the Interested Parties from obligations regarding different and/or more stringent regulations issued by the flag Administration, international organisations or other concerned parties, if applicable.

#### 1.2 Documents to be submitted

##### 1.2.1 (1/7/2011)

The documents listed in Tab 1 are to be submitted to the Society.

**Table 1 : Documentation to be submitted (1/1/2020)**

No.	I/A (1)	Document (2)
1	A	Structural fire protection, showing the method of construction, purpose of the various spaces of the ships, fire rating of bulkheads and decks, means of closing of openings in "A" and "B" class divisions, draught stops
2	A	Natural and mechanical ventilation systems showing the penetrations in "A" class divisions, location of dampers, means of closing, arrangements of air conditioning rooms

(1) A : to be submitted for approval, in four copies  
I : to be submitted for information, in duplicate.

(2) Plans are to be schematic and functional and to contain all information necessary for their correct interpretation and verification such as:

- service pressures
- capacity and head of pumps and compressors, if any
- materials and dimensions of piping and associated fittings
- volumes of protected spaces, for gas and foam fire-extinguishing systems
- surface areas of protected zones for automatic sprinkler and pressure water-spraying, low-expansion foam and powder fire-extinguishing systems
- capacity, in volume and/or in mass, of vessels or bottles containing the extinguishing media or propelling gases, for gas, automatic sprinkler, foam and powder fire-extinguishing systems
- type, number and location of nozzles of extinguishing media for gas, automatic sprinkler, pressure water-spraying, foam and powder fire-extinguishing systems.

All or part of the information may be provided, instead of on the above plans, in suitable operation manuals or in specifications of the systems.

(3) See Pt C, Ch 1, Sec 2, [4.4.1]

(4) For the assignment of the additional class notation **FIRE-MS (hot-spots)** only.

(5) Plans are to be schematic and functional and to contain all information necessary for their correct interpretation and verification such as:

- location of leakage points
- identification and type of leakage points
- type of flammable product that may leak and maximum rate in m<sup>3</sup>/h, when available
- type of arrangement provided to detect, contain or shield the leak and relevant technical details.

No.	I/A (1)	Document (2)
3	A	Means of escape and, where required, the relevant dimensioning
4	A	Automatic fire detection systems and manually operated call points
5	A	Fire pumps and fire main, including pump head and capacity, hydrant and hose locations
6	A	Arrangement of fixed fire-extinguishing systems (2) and inert gas systems
7	A	Arrangement of sprinkler or sprinkler equivalent systems, including the capacity and head of the pumps (2)
8	A	Fire-fighting equipment and firemen's outfits (or fire control plans)
9	A	Fixed fire-extinguishing system in scavenge spaces of two-stroke crosshead type engines (3)
10	A	Hydraulic calculations for fixed gas fire-extinguishing systems
11	A	Electrical diagram of the fixed gas fire-extinguishing systems
12	A	Electrical diagram of the sprinkler or sprinkler equivalent systems
13	A	Electrical diagram of power control and position indication circuits for fire doors
14	I	General arrangement plan
15	A	Combustible (fuel and lubrication) oils systems (4) (5)
16	A	Report of "thermo-scan" inspection and mapping of hot-spots (4)

(1) A : to be submitted for approval, in four copies  
I : to be submitted for information, in duplicate.

(2) Plans are to be schematic and functional and to contain all information necessary for their correct interpretation and verification such as:

- service pressures
- capacity and head of pumps and compressors, if any
- materials and dimensions of piping and associated fittings
- volumes of protected spaces, for gas and foam fire-extinguishing systems
- surface areas of protected zones for automatic sprinkler and pressure water-spraying, low-expansion foam and powder fire-extinguishing systems
- capacity, in volume and/or in mass, of vessels or bottles containing the extinguishing media or propelling gases, for gas, automatic sprinkler, foam and powder fire-extinguishing systems
- type, number and location of nozzles of extinguishing media for gas, automatic sprinkler, pressure water-spraying, foam and powder fire-extinguishing systems.

All or part of the information may be provided, instead of on the above plans, in suitable operation manuals or in specifications of the systems.

(3) See Pt C, Ch 1, Sec 2, [4.4.1]

(4) For the assignment of the additional class notation **FIRE-MS (hot-spots)** only.

(5) Plans are to be schematic and functional and to contain all information necessary for their correct interpretation and verification such as:

- location of leakage points
- identification and type of leakage points
- type of flammable product that may leak and maximum rate in m<sup>3</sup>/h, when available
- type of arrangement provided to detect, contain or shield the leak and relevant technical details.

## 2 Requirements applicable to all spaces

### 2.1 General

#### 2.1.1 (1/1/2020)

For obtaining the class notations in [1.1.1], ships are to comply with the requirements set out in this Article and:

- Chapter II-2 of the SOLAS Convention as amended and associated Codes;
- IBC Code and IGC Code, where applicable to the ship

type being considered;

- IACS Unified Interpretations in force, as applicable;
- SOLAS Unified Interpretations contained in the following documents: MSC/Circ.1081, MSC/Circ.1120, MSC/Circ.1169, MSC/Circ.1203, MSC.1/Circ.1239, MSC.1/Circ.1275, MSC.1/Circ.1276, MSC.1/Circ.1368, MSC.1/Circ.1434, MSC.1/Circ.1436, MSC.1/Circ.1437, MSC.1/Circ.1456, MSC.1/Circ.1505 and MSC.1/Circ.1511. In this case, equivalent arrangements may also be accepted by the Society; and

- e) Part C, Chapter 4;
- f) Articles [2], [3], [4] and [5] as applicable to the type of space being considered.

## **2.2 Firefighter's Outfits**

### **2.2.1 (1/1/2020)**

The minimum number of firefighter's outfits, including breathing apparatus, to be provided on board is to be as follows:

- a) 10 on passenger ships;
- b) 4 on cargo ships;
- c) 6 on oil and chemical tankers and ro-ro cargo ships;
- d) 8 on ro-ro ships and gas carriers.

The above number may be reduced, at the discretion of the Society, considering the dimensions of the ship concerned and the number of crew.

Firefighter's outfits provided for fulfilling statutory requirements may be considered for meeting this requirement.

### **2.2.2 (1/1/2020)**

The firefighter's outfits, including breathing apparatus, are to be of the same model.

### **2.2.3 (1/1/2020)**

In general, the total weight of the breathing apparatus, including any devices necessary for their functioning, is not to exceed 18,0 kg.

### **2.2.4 (1/1/2020)**

A two-way portable radiotelephone apparatus is to be available for each of the firefighter's outfits in [2.2.1] and to be explosion-proof or intrinsically safe type. Only one type of radiotelephone is to be used for this purpose. At least two of the radiotelephones are to be adapted for use by the fire-fighting squad (installed inside helmet).

### **2.2.5 (1/7/2011)**

Measures are to be taken to prevent communication from any part of the accommodation spaces, machinery spaces and cargo spaces to the navigating bridge and the manned control station, if fitted, from being impaired.

### **2.2.6 (1/1/2020)**

The firefighter's outfits are to be equally distributed in at least two fire lockers located on different decks and, in the case of passenger ships, in different main vertical zones. The fire lockers are to be clearly marked and are to have access from the open deck or through a stairway enclosure.

Fire lockers are not to be located in positions far from the accommodation spaces and their fire integrity with respect to adjacent internal spaces is to correspond to that requested for storerooms depending on their deck area.

### **2.2.7 (1/7/2011)**

The arrangement of the fire lockers is to be such that the equipment contained therein is easily accessible and ready for immediate use. Protective clothing is to be hung up and shelves are to be provided for orderly storage of any other items of the firefighter's outfits.

### **2.2.8 (1/1/2020)**

A compressor or a dedicated tank that is part of a self-contained high pressure storage system is to be provided for the refilling of the breathing apparatus. This equipment is to be either located in a dedicated room or stored along with other fire-fighting equipment. The storage room is to:

- a) be located on an upper deck in a position close to a stairway enclosure;
- b) have access from the open deck;
- c) be illuminated by the main and emergency sources of electrical power; and
- d) be provided with facilities (such as a water tank of adequate capacity surrounded by a steel wire cage) able to accommodate the maximum number of cylinders that can be recharged simultaneously and store empty and full cylinders separately.

### **2.2.9 (1/7/2011)**

When a compressor is installed:

- a) it is to be driven by its own diesel engine capable of functioning for not less than 3 hours or by the emergency source of electrical power for at least the same period of time;
- b) it is to comply with the relevant requirements in Pt C, Ch 1, Sec 10, Tab 36;
- c) flexible hoses and associated valves are to comply with Pt C, Ch 1, Sec 10, [2.6] and Pt C, Ch 1, Sec 10, [2.7], respectively; and
- d) its capacity is not to be less than 60 litres/minute.

### **2.2.10 (1/7/2011)**

When a self-contained high pressure storage system is installed:

- a) the storage tank:
  - is to have a volume of at least 1200 litres of free air per any required breathing apparatus fitted on board but is not required to exceed 50,000 litres
  - is to comply with Pt C, Ch 1, Sec 3 and the associated pipes and valves are to comply with Pt C, Ch 1, Sec 10
  - may be fed by compressors located as indicated above; alternative arrangements will be considered by the Society
  - is to be kept filled at all times



- is to be provided with a safety valve so arranged as to prevent injuries to persons.
- b) a low pressure alarm for the storage tank is to be provided in a continuously manned control station;
- c) non-return valves are to be fitted on the feeding pipes at the storage room;
- d) high pressure pipes are to run, as far as possible, outside accommodation spaces, service spaces and control stations.

### 2.3 Manuals and instructions

#### 2.3.1 (1/7/2011)

Manuals and instructions for use, maintenance and periodic tests of fire-fighting, fire detection and alarm systems and for fire-fighting equipment are to be kept in the wheelhouse or another manned control station not easily cut off by a fire in the surrounding spaces.

## 3 Accommodation spaces

### 3.1 Restricted use of combustible materials

#### 3.1.1 Passenger ships (1/1/2020)

The following applies:

- a) curtains and other suspended textile materials in public spaces are to have resistance to flame as given in Annex 1, Part 7 of the Fire Test Procedures Code (FTP Code);
- b) exposed surfaces of decks of accommodation and service spaces and control stations, with the exclusion of hard wood decks, are to have low flame spread characteristics as given in Annex 1, Part 5 of the FTP Code;
- c) exposed surfaces of hard wood decks (i.e. dancefloors, bowling lines, etc.) with a surface greater than 50 m<sup>2</sup> of public spaces are to have low flame spread characteristics as given in Annex 1, Part 5 of the FTP Code;
- d) bedding components are to comply with Annex 1, Part 9 of the FTP Code;
- e) exposed surfaces of open decks accommodating part of public spaces such as restaurants or open galleys are to have low flame spread characteristics as given in Annex 1, Part 5 of the FTP Code.

#### 3.1.2 Ships other than passenger ships (1/1/2020)

The following applies:

- a) construction method IC as defined in SOLAS Regulation Ch. II-2/9.2.3.2 is to be used;
- b) bedding components are to comply with Annex 1, Part 9 of the FTP Code;
- c) curtains and other suspended textile materials are to have resistance to flame as given in Annex 1, Part 7 of the FTP Code;
- d) subject to compliance with [3.3.2] (c), furniture and furnishing in stairways enclosures and corridors are to comply with Annex 1, Part 8 of the FTP Code;
- e) exposed surfaces of bulkheads, linings and decks of accommodation and service spaces and control stations, with the exclusion of hard wood decks, are to

have low flame spread characteristics as given in Annex 1, Part 5 of the FTP Code.

### 3.2 Structural fire protection

#### 3.2.1 Passenger ships (1/1/2020)

The following applies:

- a) doors fitted in corridor bulkheads (providing access to cabins, public spaces, etc.) are to be of self-closing type;
- b) if fitted, hold back devices are to be arranged so they may be remotely closed from the wheelhouse, unless they can be automatically released through the intervention of the fire detection system;
- c) where in Tables 9.3 and 9.4 of SOLAS Regulation II-2/9 an asterisk is shown, the division concerned is to be of at least A-0 class. However, this requirement may be waived for those separations between internal spaces and open decks;
- d) on passenger ships carrying not more than 36 passengers the exhaust ducts serving laundry and drying rooms are to be fitted with service hatches for cleaning purposes and are not to serve other spaces. This requirement does not forbid that these ducts can be served by the same air conditioning unit of accommodation and service spaces, provided that an automatic fire damper is fitted near the air conditioning unit;
- e) separations between cabins, service spaces and corridors are to be of B-15 class. In this context, on passenger ships carrying not more than 36 passengers, an A-0 class division can be considered equivalent to a B-15 class division.

#### 3.2.2 Ships other than passenger ships (1/1/2020)

The following applies:

- a) doors fitted in corridor bulkheads (providing access to cabins, public spaces, etc.) are to be of self-closing type;
- b) if fitted, hold back devices are to be arranged so they may be remotely closed from the wheelhouse, unless they can be automatically released through the intervention of the fire detection system;
- c) where in Tables 9.5, 9.6, 9.7 and 9.8 of SOLAS Regulation II-2/9 an asterisk is shown, the division concerned is to be of at least A-0 class. However, this requirement may be waived for those separations between internal spaces and open decks;
- d) boundaries within the accommodation block separating the accommodation and service spaces from machinery spaces (regardless of their fire risk category) are to be of A-60 class. However, this requirement may be waived for those machinery spaces of category 7 (see SOLAS regulations II-2/9.2.3.3.2 and 9.2.4.2.2) located within the accommodation block and containing machinery serving only accommodation and service spaces (e.g. air condition rooms and associated trunks serving only cabins and similar spaces);
- e) the exhaust ducts serving laundry and drying rooms are to be fitted with service hatches for cleaning purposes and are not to serve other spaces. This requirement does not forbid that these ducts can be served by the same air

conditioning unit of accommodation and service spaces, provided that an automatic fire damper is fitted near the air conditioning unit;

- f) separations between cabins, services spaces and corridors are to be of B-15 class. In this context, an A-0 class division can be considered equivalent to a B-15 class division.

### 3.3 Means of escapes

#### 3.3.1 Passenger ships (1/1/2020)

Spaces having a deck area exceeding 30 m<sup>2</sup> are to be provided with at least two independent escape routes, the primary escape route is to be a door directly to a corridor or an open deck. For spaces having a deck area exceeding 50 m<sup>2</sup> the secondary means of escape is also to consist of a door leading to a corridor, and is to be widely separated from the primary means of escape.

#### 3.3.2 Ships other than passenger ships (1/1/2020)

The following applies:

- a) dead end corridors are prohibited. A part of a corridor that has a depth not exceeding its width is considered a recess and is acceptable;
- b) spaces having a deck area exceeding 30 m<sup>2</sup> are to be provided with at least two independent escape routes; the primary escape route is to be a door directly to a corridor or an open deck. For spaces having a deck area exceeding 50 m<sup>2</sup> the secondary means of escape is also to consist of a door leading to a corridor, and is to be widely separated from the primary means of escape;
- c) furniture and furnishing in stairways and corridors, if any, are to be fixed to the ship's structure and are not to obstruct the escape routes.

### 3.4 Fire detection and alarm system

#### 3.4.1 Passenger ships (1/1/2020)

Heat detectors may be installed in refrigerated chambers and other spaces (such as saunas and steam baths) or areas (galleys above deep fat fryers and ovens) where the presence of vapour or condensation in the normal working conditions is expected.

#### 3.4.2 Ships other than passenger ships (1/1/2020)

In all accommodation, service spaces and control stations there is to be installed an approved automatic fire detection and alarm system of addressable type and in accordance with the Fire Safety Systems Code (FSS Code). Smoke detectors are to be used, except that heat detectors can be installed in refrigerated chambers and other spaces (such as saunas and steam baths) or areas (galleys above deep fat fryers and ovens) where the presence of vapour or condensation in the normal working conditions is expected.

### 3.5 Portable fire extinguishers

#### 3.5.1 Passenger ships (1/1/2020)

The following applies:

- a) at least one extinguisher is to be provided in pantries and laundries and public spaces;
- b) at least two extinguishers of suitable type for deep fat fryers are to be provided in the galley;
- c) extinguishers suitable for use on electrical equipment are to be located as follows:
- at least two on the navigating bridge; and
  - one close to any electrical switchboard of power not less than 20 kW.

#### 3.5.2 Ships other than passenger ships (1/1/2020)

The following applies:

- a) two extinguishers are to be provided in corridors or stairways at each deck. In addition, at least one extinguisher is to be located in all pantries, laundries, crew dayrooms and similar spaces
- b) at least two extinguishers of suitable type for deep fat fryers are to be provided in the galley
- c) extinguishers suitable for use on electrical equipment are to be located as follows:
- at least two on the navigating bridge; and
  - one close to any electrical switchboard of power not less than 20 kW.

### 3.6 Hydrants and fire hoses

#### 3.6.1 (1/7/2011)

Hydrants are to be located so that any point of the accommodation spaces can be reached by two streams of water from fire hoses of single length fed by different hydrants: this requirement may be waived for those parts of the accommodation spaces where double length of hoses can be used without the need to bend and twist them.

#### 3.6.2 (1/7/2011)

A fire hose is to be provided for each hydrant.

## 4 Machinery spaces

### 4.1 Emergency escape and access

#### 4.1.1 (1/1/2020)

One of the escape routes from the engine control room is to be independent from the engine room.

#### 4.1.2 (1/4/2021)

Machinery spaces and workshops that are not part of the engine room are to have at least one escape route independent from the engine room.

### 4.2 Ventilation

#### 4.2.1 (1/1/2020)

At least one of the machinery space fans, is to be of the reversible type and fed by the emergency source of power.

**4.2.2 (1/7/2011)**

All dampers, including fire dampers, at engine room boundaries are to be made of corrosion-resistant materials, such as stainless steel and brass.

**4.2.3 (1/1/2020)**

Means for closing inlet and outlet ventilation openings are to be positioned in easily accessible locations. These means of closing are to:

- a) be provided with controls operable at a height not greater than 1,80 m above the deck and indicators showing their position (open or closed); and
- b) have the same fire integrity of the boundary they are part of.

**4.3 Fire control station****4.3.1 (1/1/2020)**

Controls for release of the local fire-extinguishing system, stopping of the fuel pumps and of ventilation fans, are to be located in a normally manned control station ("fire control station" for the purpose of this Section).

**4.3.2 (1/1/2020)**

Controls for release of the fixed fire-extinguishing system in the engine room and closing of the fuel oil valves may be located outside the fire control station provided that they are located in readily accessible positions outside the engine room.

**4.3.3 (1/1/2020)**

The CCTV system required in [4.7] and a slave panel for the fire detection system are to be located in the fire control station in the proximity of the controls mentioned in [4.3.1].

**4.4 Hydrants and fire hoses****4.4.1 (1/7/2011)**

The emergency fire pump is to have a capacity of not less than 72 m<sup>3</sup>/hour. If the pump is used for feeding other systems required to operate during a fire, its capacity is to be increased accordingly.

**4.4.2 (1/7/2011)**

The space containing the emergency fire pump and its mover is to be ventilated and provided with emergency light. The pump's prime mover is to be provided with heating unless the space in which it is located has adequate heating facilities.

**4.5 Precaution against oil ignition****4.5.1 (1/7/2011)**

The requirements of this Article apply to systems for fuel oils, thermal oils, lubricating oils and hydraulic oils.

The arrangements of tanks, piping for oil under pressure, oil processing machinery etc. are to be such that the danger of leakage and ignition is reduced to a minimum.

**4.5.2 (1/7/2011)**

The following installations are not to be located in spaces containing combustion engines and oil fired boilers:

- a) oil fired thermal oil heaters
- b) fuel oil purifiers
- c) incinerators.

**4.5.3 (1/1/2020)**

Rooms containing the installations in [4.5.2] are to be protected by a fixed fire-extinguishing system. If the volume of the space exceeds 500 m<sup>3</sup> and other machinery and equipment are installed therein, a local application system is also to be provided.

**4.5.4 (1/7/2011)**

Hydraulic power aggregates located within the engine room are to be provided with shielding plates where facing major ignition hazards, such as combustion engines (if located at a distance less than 10 m) and electric motors (if located at a distance less than 3 m).

**4.5.5 (1/7/2011)**

Oil piping with working pressure above 15 MPa located within a machinery space of category A is not to run above combustion machinery unless arranged in jacketed piping. Flanges and couplings are to be provided with steel sheet screens unless arranged in screened positions (e.g. underneath tight floor plating).

**4.5.6 (1/7/2011)**

Insulation of hot surfaces is to be protected by steel sheet cladding or other protection approved by the Society; such protection is to be easy to dismantle and assemble wherever inspection of the protected equipment is necessary.

**4.6 Fire detection and alarm system****4.6.1 (1/7/2011)**

The requirements in Ch 3, Sec 1, [3.2] for ships with periodically unattended machinery space are to be complied with.

**4.6.2 (1/7/2011)**

All machinery spaces, whether or not of category A, are to be covered by the system.

**4.6.3 (1/7/2011)**

Smoke detectors are to be used. In addition, flame detectors are to cover all internal combustion engines, heated fuel oil separators, oil fired boilers and similar equipment.

**4.6.4 (1/7/2011)**

For workshops (e.g. welding workshops) where fumes may cause false alarms, the relevant smoke detectors can be connected to a timer function that automatically resets after not more than 20 minutes. In addition, one or more heat detectors not connected to this timer are to be installed.

**4.7 Monitoring system****4.7.1 (1/1/2020)**

A colour CCTV monitoring system is to be provided to cover all engines with rated power above 375 kW, heated fuel oil separators, oil fired boilers and all oil fired equipment, except for the emergency generator. Monitors are to be available in the fire control station or in the engine control room, if the latter is not an integral part of the engine room.

**4.8 Local application systems****4.8.1 (1/7/2011)**

In addition to spaces specified in SOLAS Regulation II-2/10.5.6.3, the system is to protect the fire hazard portions

of any internal combustion machinery with a total power output of not less than 375 kW.

**4.8.2 (1/7/2011)**

The local application system is not to be dependent on the fire main.

**4.8.3 (1/7/2011)**

The failure of the main source of electrical power is not to put out of order the local application system protecting fire hazard areas in the space where the main source of electrical power is located.

**4.8.4 (1/7/2011)**

An installation consisting of pumps driven directly by a dedicated diesel engine is to be capable of delivering water at full pressure within 20 seconds.

**4.8.5 (1/7/2011)**

Use of sea water is not accepted within the first 20 minutes of the functioning of the system. The pump is to be able to operate under all conditions without the use of any self-priming system. The pump and its mover are to be provided with heating unless the space in which they are located has adequate heating facilities.

**4.8.6 (1/7/2011)**

The pump capacity is to be designed to simultaneously cover risk objects in the same space located at less than 3 m from each other, even if the machinery concerned is protected by separated sections. The same piece of machinery is to be protected simultaneously.

**4.8.7 (1/7/2011)**

Discharge of water directly into electric generators and engine air intakes is to be avoided.

**4.8.8 (1/7/2011)**

A test and drain valve is to be fitted. The valve is to be provided with means to secure it in a closed position after use.

**4.8.9 (1/7/2011)**

The system is to operate automatically by the combined intervention of a smoke detector and a flame detector; however, it is to be possible to operate the system manually.

**4.8.10 (1/7/2011)**

System components such as section valves, test and drain valves, any accumulators, the pump unit and its power supply and control equipment are to be readily accessible and located outside the protected spaces.

**4.9 Total flooding fire-extinguishing systems**

**4.9.1 (1/7/2011)**

The following spaces are to be protected by a fixed fire-extinguishing system:

- a) spaces containing main electric propulsion systems (if fitted), including electric motors if inside the hull, switchboards and transformers serving such motors. This requirement may be waived for those bow thruster rooms not containing other fire risk items;
- b) spaces containing the main switchboards (of any size) and switchboards with capacity exceeding 1000 kW;
- c) an engine control room that is not part of the engine room.

**4.9.2 (1/4/2021)**

The extinguishing media used in spaces in [4.9.1] a) and b) are not to be capable of causing damage to non-redundant essential services.

**4.10 Portable fire extinguishers**

**4.10.1 (1/1/2020)**

A fire extinguisher suitable for use on electrical equipment is to be located near each electrical switchboard of a power of not less than 20 kW (for switchboards not more than 1 m apart, a single fire extinguisher is deemed sufficient).

**4.10.2 (1/7/2011)**

At least two fire extinguishers of the type mentioned in [4.1] are to be located in the engine control room.

**4.10.3 (1/7/2011)**

Fire extinguishers are also to be provided:

- a) four at the lowest level and at each platform level of each main propulsion engine; and
- b) one near each auxiliary engine.

**5 Special Provisions to prevent occurrence of a fire in machinery spaces**

**5.1 Portable fire extinguishers**

**5.1.1 General (1/1/2020)**

The present section applies to the design, operation and maintenance of systems conveying combustible oils, fitted or in transit within machinery spaces, irrespective of its fire category.

**5.2 Detection and identification of critical points**

**5.2.1 General (1/1/2020)**

A detailed procedure with the aim of planning periodical inspections within the machinery spaces is to be available on board the ship.

The procedure is to include at least the following information:

- a) intervals between the inspections;
- b) requirements for preparation of the inspections (plan and list of machinery, piping, etc., run/stop of auxiliary systems) and fast response actions;
- c) safety measures for the crew and instrumentation (Personal Protective Equipment (PPE), thermal cameras, tools, etc.);
- d) instruments to record any report, corrective action and follow-up of detected critical points and any anomalies and damages of the items listed in [5.2.2] below;
- e) technical specifications or reference to technical specification, Material Safety Data Sheet (MSDS) and installation manuals of systems present on board for leaks, spillage or ignition containment and prevention.

**5.2.2 (1/1/2020)**

The inspection is to be carried out paying attention to the following items, whose anomalies and damages are to be

recorded as per previous [5.2.1] d) and kept onboard for any future use in planned inspections:

- flexible hoses, relevant fittings and connections;
- insulation, jacketing and supports of combustible oils piping, including tank sounding pipes, air vents and level measuring devices;
- spray/spill shield protections on joints of combustible oils piping;
- insulation and protection against sprays fitted on hot surfaces and equipment (exchangers, exhaust gas piping, etc.);
- items found subjected to unusual or unexpected vibrations;
- springs, tab washers, locking wires and any other device to limit or suppress vibrations;
- actual presence of combustible oil spills.

### 5.2.3 (1/1/2020)

Additional systems or procedures on board for the permanent marking of critical points and early leakage detections are allowed; they are to be included in the [5.2.1] and to be evaluated on a "case-by-case" basis.

### 5.2.4 (1/1/2020)

All surfaces in the engine room (i.e. engines, exhaust ducts, steam ducts and similar equipment) that may be expected to reach a temperature above 220°C are to be identified by means of an infrared scanning camera during their normal operation (85% of MCR).

The verification is to be carried out by certified personnel using a calibrated instrument.

Corrective actions (that may include improved insulation or improved heat dissipation arrangements) are to be preliminarily approved by the Society and their effectiveness confirmed by additional verification.

The infrared scanning is to be repeated at any annual machinery survey.

### 5.2.5 (1/1/2020)

An automatic oil-leak detection system is not required. However, any system provided for this purpose on a voluntary basis, is to be preliminarily evaluated by the Society to verify its characteristics of installation, operation and communication with the ship's automation, if any. In any case, the system is not to cause loss of propulsion and maneuvering of the ship.

## 5.3 Oil leakage prevention

### 5.3.1 (1/1/2020)

The provisions of this paragraph are additional to those in [4.5.2], [4.5.4], [4.5.6] and Pt C, Ch 1, Sec 10, [2], where applicable.

### 5.3.2 (1/1/2020)

Flexible hoses assembly is to comply with the provisions of IMO Circular MSC.1/Circ.1321, paragraphs 2.1 and 2.2. Installation, verification and testing should be as per paragraphs 2.3 to 2.7, or equivalent.

### 5.3.3 (1/1/2020)

Bellows expansion joints on combustible oils piping are to be protected against mechanical damage where necessary.

### 5.3.4 (1/1/2020)

Instruments (e.g. pressure gauges, sight glasses, etc.) are to be fitted with an isolating valve at the take off point and the point connection pipe made without joints, with path the shortest possible. Take off points for instruments are to be kept the minimum necessary.

On cargo ships, the installation of level gauges with penetrations below the top of oil tanks is not allowed.

## 5.4 Oil leakage containment

### 5.4.1 (1/1/2020)

In pressurized combustible oil systems, the leakage points are to be enclosed with a containment in way of spray shield ( Fig 1).

### 5.4.2 (1/1/2020)

A drainage to a safe recovery collecting is to be provided for every containment ( Fig 1).

### 5.4.3 (1/1/2020)

The containment is to be easily accessible for maintenance.

### 5.4.4 (1/1/2020)

In case of screwed-type connection, or when the space makes the provision of a containment not practicable, the use of an approved self-adhesive containment tape is deemed acceptable. In this latter case, additional measures to grant the tightness of flange bolts are required ( Fig 1).

### 5.4.5 (1/1/2020)

The use of Copper or Aluminum-Brass drainage piping is allowed only for a length less than 1 m.

In case of refitting, steel piping only are admitted.

## 5.5 Prevention of ignition

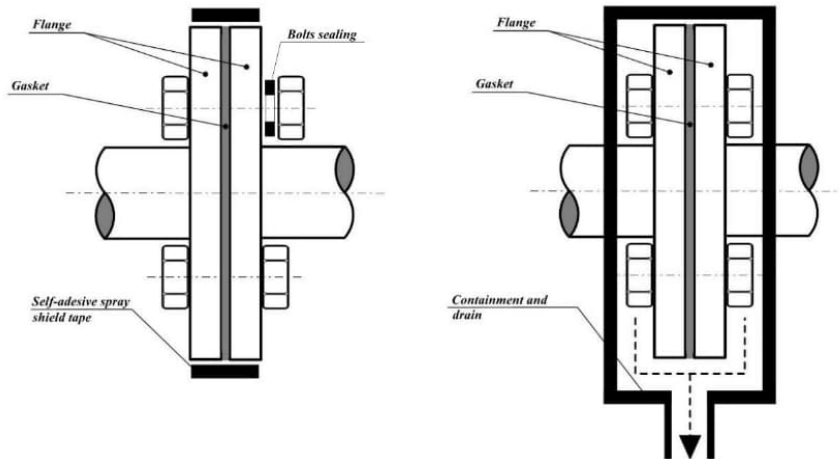
### 5.5.1 (1/1/2020)

The combustion oil systems are to be arranged to avoid, as far as practicable, the proximity to ignition sources. In this context particular attention is to be paid at the turbochargers area.

### 5.5.2 (1/1/2020)

The connection points in steel sheet cladding required in previous item [4.5.6] to protect the insulation are to be made capable to avoid seeping or dripping of oil inside.

Figure 1 (1/1/2020)



## 6 Cargo decks and cargo spaces

### 6.1 Introduction

#### 6.1.1 (1/7/2011)

The Rules address the following ship types:

- oil tankers and chemical tankers (including combinations);
- gas carriers;
- general cargo ships and bulk carriers;
- ro-ro cargo ships and ro-ro passenger ships;
- container ships.

For ships of other types, the requirements for obtaining the notation **FIRE-CS** will be determined on a case-by-case basis, taking into account the characteristics of the ship being considered.

### 6.2 Oil and chemical tankers

#### 6.2.1 Cargo pump room (1/1/2020)

- When a CO<sub>2</sub> fixed fire-extinguishing system is provided as a total flooding extinguishing system, the quantity of CO<sub>2</sub> needed is to be calculated on the basis of 45% of the gross volume of the protected space. If the gas fire-extinguishing system is of another type, its quantity is to be increased by at least 30% in respect of the design concentration.
- A smoke detection system suitable for use in gas hazardous atmosphere is to be provided. The system is to be monitored from the cargo control room (if provided) and from the navigating bridge.
- The following portable fire extinguishers are to be provided:
  - one at the entrance of the space; and
  - two in readily accessible positions in the lower part of the space.

#### 6.2.2 Inert gas system (1/7/2011)

An inert gas generating system in compliance with SOLAS Ch. II-2, Reg.4.5.5 is to be provided regardless of the deadweight.

#### 6.2.3 Gas detection system (1/7/2011)

The fixed gas detection system required by SOLAS Ch. II-2, Reg.4.5.10 is also to cover all other enclosed spaces in the cargo area, including ballast tanks, but excluding cargo tanks.

#### 6.2.4 Fire main (1/1/2020)

- The fire main is to be arranged so that a rupture at any part of it will not affect the delivery of the water in the cargo area.
- Isolation valves are to be steel ball valves; other arrangements (e.g. the use of valves tested as fire safe) will be considered by the Society. All fire pumps are to be remotely controlled from the wheelhouse or the manned fire station, if provided.
- All hydrants in the deck area are to be provided with fire hoses contained in boxes made of corrosion-resistant materials.
- Any metallic component of fire hoses is to be made of corrosion-resistant material not capable of producing sparks if dragged on the deck's surface.

#### 6.2.5 Deck foam system (1/1/2020)

- An independent foam main is to be provided for the deck foam extinguishing system. The manifold is to be arranged along the centreline as a single line with foam outlet branches to both port and starboard arranged just aft of each monitor. At least one foam outlet is to be fitted close to each of the two monitors required to be located in front of the accommodation block.
- The foam applicators required by SOLAS are to be stored as follows:
  - two next to the front of the accommodation facing the cargo area; and
  - two at a suitable position ready for use on the cargo manifolds.
- Foam applicators are to be contained in boxes made of corrosion-resistant materials.
- Any metallic component of foam applicators is to be made of metallic, corrosion-resistant material not capable of producing sparks if dragged on the deck's surface.

- e) Redundancy for foam mixing units and foam concentrate pumps is to be provided.
- f) Storage tanks for foam concentrate, foam mixing units and foam concentrate pumps are to be located in a dedicated room. For ships below 4000 gross tonnage this requirement may be waived.
- g) The water supply to the foam extinguishing system may be supplied by a dedicated water pump or by the fire pumps. In the latter case, the capacity of the pumps is to be sufficient for simultaneously meeting the requirement of the foam system and the fire main.
- h) Foam monitors are to have a free movement of plus or minus 45° in the vertical plane and in the horizontal plane they are to be able to point at any part of the deck intended to be protected. These monitors are to be provided with means for locking them at any position within these ranges. Monitor foundations are to be capable of withstanding the loads that they will be subjected to on the open deck.
- i) The two foam monitors at each side of the forward end of the accommodation block and the monitor protecting the cargo manifold (and any associated valve) are to be capable of being remotely controlled (in both vertical and horizontal directions) from a protected position (e.g. the wheelhouse) affording an unobstructed view of the cargo area. The manual operation of such monitors is always to be possible.

#### 6.2.6 Protection for life-saving appliances (1/7/2011)

Unless they are located in positions that can be considered shielded from a fire in the cargo area (e.g. free fall lifeboats located aft), lifeboats and the area surrounding them are to be cooled by means of sprayed water with a delivery of not less than 10 l/min/m<sup>2</sup>. The system can be supplied by the fire main provided that the performance of this system is not affected by the contemporary activation of the sprayed water. Controls for the activation of the sprayed water may be located in a position near the lifeboats or in the wheelhouse.

### 6.3 Gas carriers

#### 6.3.1 Spaces containing cargo handling equipment (1/1/2020)

- a) The following spaces are to be protected by a CO<sub>2</sub> fixed fire-extinguishing system:
  - cargo re-liquefy room, if fitted; and
  - electrical equipment room or similar spaces located in the cargo area.

The use of other extinguishing media will be considered by the Society.

- b) When a CO<sub>2</sub> fixed fire-extinguishing system is provided as a total flooding extinguishing system, the quantity of CO<sub>2</sub> needed is to be calculated on the basis of 45% of the gross volume of the protected space. If the gas fire-extinguishing system is of another type, its quantity is to be increased by at least 30% in respect of the design concentration.

#### 6.3.2 Smoke detection system (1/7/2011)

A smoke detection system suitable for use in gas hazardous atmosphere is to be provided in all spaces located within the cargo area. The system is to be monitored from the cargo control room (if provided) and from the navigating bridge.

#### 6.3.3 Fire main (1/1/2020)

- a) The fire main system is to comply with [6.2.6].
- b) At least one monitor fed by the fire main is to be installed as additional protection for the cargo manifold area.

The monitor is to be capable of producing a water jet providing a coverage of not less than 10 l/min/m<sup>2</sup> of the horizontal area of the cargo manifold area plus an additional area extending 2 m out of the perimeter of the cargo manifolds. Remote operation from a safe position outside of the cargo area as well as manual operation of the monitor and relevant section valve are to be provided. The functioning of the monitor is not to affect the required performances (delivery and pressure) of the fire main that may be required to operate simultaneously.

#### 6.3.4 Powder fire-extinguishing system (1/7/2011)

- a) The powder distribution lines and the pressure gas lines are to be made of stainless steel or equivalent corrosion-resistant materials.
- b) Only nitrogen is to be used for pressurising the powder tank.
- c) The layout of the system (i.e. number of powder tanks, number of nitrogen bottles, maximum length of pipes, maximum number of curves, distance from the powder tank to the monitors, etc.) is to conform to a prototype successfully subjected to a full-scale test.
- d) The dry powder stored on the tanks is to provide for 60s operation of each system, when all attached monitors are activated.
- e) The system is to be so designed that ingress of water in the pipes is avoided.
- f) Dry powder hose stations are to be contained in boxes made of corrosion-resistant materials.
- g) Any metallic component of dry powder hoses is to be made of metallic, corrosion-resistant material not capable of producing sparks if dragged on the deck's surface.

#### 6.3.5 Water spray system (1/7/2011)

Piping of the water spray system fitted in accordance with Chapter 11 of the IGC Code is to be made of metallic, corrosion-resistant material (e.g. CuNi or equivalent).

#### 6.3.6 Fire extinguishing in the gas venting arrangement (1/7/2011)

Venting masts for the cargo tank venting system on liquefied gas carriers are to be provided with a fixed system for extinguishing a fire at the vent outlet. The type of media used as well as the design of the system are to be to the Society's satisfaction.

#### 6.3.7 Protection for life-saving appliances (1/7/2011)

The requirements in [6.2.6] apply.

## 6.4 General cargo and bulk carriers

### 6.4.1 Fire detection (1/7/2011)

A detection system is to be provided in all dry cargo holds.

### 6.4.2 Fixed fire-extinguishing system for cargo holds (1/7/2011)

- a) The storage room for the fixed fire-extinguishing medium for the holds, as well as any associated discharge control, is to be located in a position reachable without passing through the section(s) of the ship where the holds are located.
- b) In the case of refrigerated holds, precautions are to be taken in order to avoid the formation of ice within the pipes due to the presence of water (condensation).
- c) If a CO<sub>2</sub> fixed fire-extinguishing system is provided as a total flooding extinguishing system, the quantity of CO<sub>2</sub> needed is to be calculated on the basis of 40% of the gross volume of the largest hold protected.

## 6.5 Ro-ro ships

### 6.5.1 Fire detection (1/7/2011)

Ro-ro and special category spaces are to be covered by an addressable type fire detection system; a combination of smoke and heat detectors is to be utilised in the system. The location of each detector is to be shown either on a mimic panel or using a computer program.

### 6.5.2 TV monitoring system (1/1/2020)

A colour CCTV monitoring system is to be provided to cover all decks, including moveable decks. Monitors are to be placed in a manned control station.

## 6.6 Container ships

### 6.6.1 Fixed fire-extinguishing system for enclosed cargo holds (1/7/2011)

The requirements in [6.4.2] apply.

### 6.6.2 Fire-extinguishing systems for partially open or open cargo spaces (1/7/2011)

- a) Where partially weathertight hatchway covers are fitted, the provisions of MSC/Circ 1087 and [6.4.2] are to be applied.
- b) In the case of open-top container ships, MSC/Circ. 608/Rev.1 applies. The pump associated with the system is to be remotely controlled from the manned fire control station, if fitted, or the wheelhouse. Isolation valves are to be operable in positions outside the boundaries of the cargo holds concerned.

### 6.6.3 Fire detection (1/7/2011)

A detection system is to be provided in all cargo holds. In the case of open-top container ships or ships fitted with weathertight hatchway covers, precautions are to be taken against damage to detectors due to water leakage.



# SECTION 18 CARRIAGE OF SPECIFIC SOLID CARGOES IN BULK

## 1 General

### 1.1 Application

#### 1.1.1 (1/8/2011)

This Section provides the criteria for the assignment of the following additional class notations, in accordance with Pt A, Ch 1, Sec 2, [6.14.24]:

- **IMSBC-A**, assigned to ships specially constructed or specially fitted for the carriage of IMSBC Code Group A cargoes, having actual moisture content in excess of their Transportable Moisture Limit (TML), in accordance with the requirements in [2].
- **IMSBC-nitrate**, assigned to ships specially designed for the carriage of IMSBC Code Group B nitrate cargoes, in accordance with the requirements in [3].
- **IMSBC-non cohesive**, assigned to ships specially designed for the carriage of non cohesive cargoes with an angle of repose less than or equal to 30°, in accordance with the requirements in [4]. It is highlighted that the same cargoes may be carried with an angle of repose greater than 30°, irrespective on the assignment of the notation **IMSBC-non cohesive**.

#### 1.1.2 (1/8/2011)

For the purpose of the assignment of the Additional Class Notations listed in [1.1.1], the relevant requirements of this Chapter are to be complied with.

It is intended that the carriage of a specific cargo is subject to the compliance with all the requirements stated in these

Rules and in the applicable statutory Regulations, in particular in the IMSBC Code for the carriage of that cargo.

Cargoes for which each of the above notations is granted are to be listed in the Certificate of Classification.

### 1.2 Definitions

#### 1.2.1 (1/8/2011)

- **Angle of repose**: the maximum slope angle of non-cohesive (i.e. free-flowing) granular material. It is measured as the angle between a horizontal plane and the cone slope of such material;
- **Group A**: cargoes which may liquefy if shipped at a moisture content in excess of their TML;
- **Group B**: cargoes which possess a chemical hazard which could give rise to a dangerous situation on a ship;
- **IMSBC Code**: International Maritime Solid Bulk Cargoes Code, IMO Resolution MSC.286(85), in the text: the Code;
- **Non Cohesive material**: dry materials that readily shift due to sliding during transport;
- **Transportable Moisture Limit (TML)**: the maximum moisture content of the Group A cargoes.

### 1.3 Documents to be submitted

#### 1.3.1 (1/8/2011)

The documents listed in Tab 1 are required.

**Table 1 : Documentation to be submitted (1/8/2011)**

No.	I/A (1)	Document
1	I	List and characteristic of the cargoes
2	A	IMSBC-A: Booklet with the information to the Master
3	A	IMSBC-A: Structural drawings of newly fitted structures, if any
4	A	IMSBC-A: Structural drawings of movable bulkheads, if any
5	A	IMSBC-A: Information to the Master for movable bulkheads
6	A	IMSBC-nitrate: Lay-out and arrangements of water fire extinguishing additional system
7	I	IMSBC-nitrate: Calculation of fire extinguishing additional system water quantity for IMSBC-nitrate
8	A	IMSBC-nitrate: Booklet with the information to the Master
9	A	IMSBC-non cohesive: Booklet with the information to the Master
<p>(1) A : to be submitted for approval, in four copies I : to be submitted for information, in duplicate.</p>		

## 2 Class notation IMSBC-A

### 2.1 General

#### 2.1.1 (1/8/2011)

Ships specially constructed or specially fitted for the carriage of cargoes Group A having a moisture content in excess of their TML are to comply with the following requirements.

### 2.2 Specially constructed ships

#### 2.2.1 Stability criteria (1/8/2011)

The following criteria and requirements apply for each loading condition; with reference to Fig 1:

- a) the righting lever curve (GZ liquid curve) is to be calculated considering the cargo in the holds as being liquid
- b) for the purpose of heeling arm curve calculation, the cargo in the holds is to be considered as a bulk cargo subject to a shift equal to 25°
- c) the angle of heel  $\delta_{EQ}$  is to be not greater than 12° or than the angle at which the deck edge is immersed
- d) the angle  $\delta_F$  is defined as the lower of the following angles:
  - 40°
  - the angle at which the difference between the GZ liquid curve and the heeling arm reaches its maximum value
  - the first downflooding angle
- e) the minimum residual area  $A_R$  comprised between the heeling arm curve and the GZ liquid curve, from  $\delta_{EQ}$  to  $\delta_F$ , is to be greater than 0,075 m rad
- f) the initial metacentric height GM, after correction for free surface effects according to Pt B, Ch 3, Sec 2, [4.2], is to be not less than 0,30 m
- g) for ships subject to the SOLAS Convention, the initial metacentric height GM (or the vertical distance KG between the baseline and the centre of gravity), after correction for free surface effects according to Pt B, Ch 3, Sec 2, [4.2], has to fulfill the GM (or KG) limiting curve, as applicable (see Note 1). This requirement does not apply to ships with type B-60 or B-100 freeboard, provided that no cargo on deck is carried.

Note 1: Solas Convention: Ch. II-1 part B-1 Reg. 5-1 for ships constructed on or after 1 January 2009, or Ch. II-1 part B-1 Reg. 25-8 for ships constructed between 1 February 1992 and 31 December 2008.

#### 2.2.2 Information to the Master (1/8/2011)

Information regarding the stability is to be provided to the Master in the form of a separate booklet. As a minimum, the booklet is to contain the following items:

- a general description of the ship
- instructions on the requirements and criteria to be fulfilled according to [2.2.1]
- instructions on the use of the booklet with a working example
- taking into account the information already provided in the approved Trim and Stability booklet:
  - general arrangement plan showing watertight compartments, means of closures, vents, downflooding points, permanent ballast
  - hydrostatic curves or tables and cross curves of stability
  - capacity plan or tables showing capacities and centres of gravity for each cargo hold
  - tank sounding tables showing capacities, centres of gravity, and free surface data for each tank
  - table of liquid free surface corrections for the cargo holds
  - volumetric heeling moments at 25° for cargo holds at different filling ratio
- typical loading conditions with the relevant stability calculations.

#### 2.2.3 Hull strength (1/8/2011)

Boundary structures of cargo holds are to be calculated considering the cargo as a liquid. In case of cargo holds partly filled, sloshing loads are also to be taken into account.

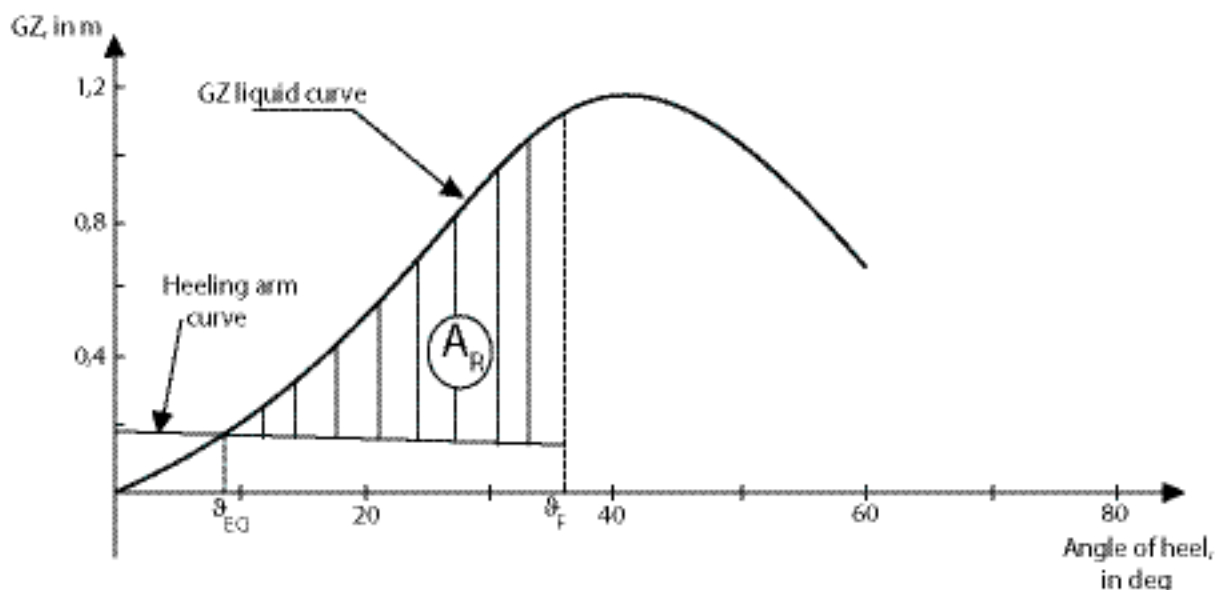
At this purpose, the level of liquid inside the holds is to be considered at the rated upper surface of the bulk cargo (horizontal ideal plane of the volume filled by the cargo), as defined in Pt B, Ch 5, Sec 6, [3.1.2]. The density of the liquid is to be assumed equal to 1,0 t/m<sup>3</sup>.

The criteria for the strength checks of the boundary structures are those in Part B, Chapter 7 or Part B, Chapter 8, as applicable depending on the ship length, and Part E, for ships with one of the following service notations:

- **bulk carrier ESP**
- **combination carrier ESP**
- **ore carrier ESP**

For ships with the service notation **bulk carrier ESP CSR**, the requirements are those in Part B, Chapter 7 and in the "Common Structural Rules for Bulk Carriers and Oil Tankers".

Figure 1 : Stability criteria (1/8/2011)



## 2.3 Ships specially fitted

### 2.3.1 Stability criteria (1/8/2011)

The requirements set out in [2.2.1] are to be complied with. This does not prevent the installation of watertight bulkheads (either fixed or movable) aimed at reducing the effect of free surface created in cargo holds by considering the cargo as liquid.

### 2.3.2 Information to the Master (1/8/2011)

The requirements set out in [2.2.2] are to be complied with.

Instructions regarding the fitting of movable bulkheads, if foreseen, are to be included in the booklet.

### 2.3.3 Hull strength (1/8/2011)

The requirements set out in [2.2.3] are to be complied with.

Where movable bulkheads are fitted, the following are to be complied with:

- the movable bulkheads are made of steel
- their scantling are to be adequate to sustain the loads indicated in [2.2.3].

## 3 Class notation IMSBC-nitrate

### 3.1 General

#### 3.1.1 (1/8/2011)

Ships intended for the carriage of the following cargoes among Group B cargoes, as defined by the Code for which the fixed gas fire-extinguishing system is ineffective (see

Note 1) are to comply with the requirements set out in this article:

- Aluminium nitrate, UN 1438
- Ammonium nitrate, UN 1942
- Ammonium nitrate based fertilizers, UN 2067
- Ammonium nitrate based fertilizers, UN 2071
- Barium nitrate, UN 1446
- Calcium nitrate, UN 1454
- Lead nitrate, UN 1469
- Magnesium nitrate, UN 1474
- Potassium nitrate, UN 1486
- Sodium nitrate, UN 1498
- Sodium nitrate and Potassium nitrate, mixture, UN 1499

Note 1: Reference is made to IMO MSC/Circ. 1146 as it may be amended.

## 3.2 Fire protection

### 3.2.1 (1/8/2011)

The cargoes holds are to be protected by means of a copious quantity of water, readily available, that is not to be less than 72 m<sup>3</sup>/h. This value may be reduced, upon consideration by the Society, for cargo holds of reduced dimensions.

The fire main may be used for meeting the above requirement providing that the following is achieved:

- the ready availability of water is to be granted by means of automatic or remote start of the fire pumps, or maintaining the fire main pressurized;
- fire hoses are to be readily available in order to grant four jets of water in any hold that may be affected by the fire. In general, two jets of water are to be provided from a single length of hose.

The use of alternative other water-based systems is to be considered by the Society on a case by case basis.

### 3.3 Stability criteria

#### 3.3.1 (1/7/2012)

As a consequence of the use of water-based fire-fighting system, the cargoes may be subject to fluidization; therefore the impact of the possible free surfaces on the stability of the ship is to be considered along with the addition of weight introduced (water).

For each loading condition envisaging the carriage of one of the cargoes listed in [3.1], the stability of the ship is to be verified considering that the whole cargo in each single hold at a time, in which the above cargoes are carried, is in a liquid state. The following criteria and requirements apply:

- the volume  $V_{CL}$ , in  $m^3$ , occupied by the cargo in the liquid state in a hold is given by the following formula:

$$V_{CL} = V_C + V_W$$

where:

$V_C$  : volume of the cargo in the hold in the solid state, in  $m^3$

$V_W$  : volume of water considered as being entered in the hold, in  $m^3$ , to be taken as the one corresponding to the lowest amount of water among the following:

- 10% in weight of the cargo in the hold, above the cargo
  - the quantity of water necessary to be added above the cargo when at the solid state, in order to completely fill the volume of the hold (hatch included)
  - 1 m of water laying on the cargo assumed at the solid state
- the density  $\delta_{AV}$ , in  $t/m^3$ , of the cargo in the liquid state is given by the following formula:

$$\delta_{AV} = \frac{\delta_C V_C + 1,025 V_W}{V_{CL}}$$

where  $\delta_C$  is the density of cargo at the solid state, in  $m^3$

- the weight  $W_{CL}$ , in t, of the cargo in the liquid state is given by the following formula:

$$W_{CL} = \delta_{AV} V_{CL}$$

- the stability of the ship in the above conditions is to be evaluated according to the intact stability requirements in Pt B, Ch 3, Sec 2.

### 3.4 Information to the Master

#### 3.4.1 (1/8/2011)

Information regarding the stability is to be provided to the Master in the form of a separate booklet. As a minimum, the booklet is to contain the following items:

- a general description of the ship
- instructions on the requirements and criteria to be fulfilled according to [3.3]
- instructions on the use of the booklet with a working example

- taking into account the information already provided in the approved Trim and Stability booklet
  - general arrangement plan showing watertight compartments, means closures, vents, downflooding points, permanent ballast compartments
  - hydrostatic curves or tables and cross curves of stability
  - capacity plan or tables showing capacities and centres of gravity for each cargo hold
  - tank sounding tables showing capacities, centres of gravity, and free surface data for each tank
  - table of liquid free surface corrections for the cargo holds
- typical loading conditions with the relevant stability calculations.

## 4 Class notation IMSBC-non cohesive

### 4.1 General

#### 4.1.1 (1/8/2011)

Non-cohesive materials are those bulk cargoes that readily shift due to sliding during transport. The angle of repose is a characteristic of these materials which is indicative of cargo stability.

Ships intended for the carriage of solid cargoes, categorized into either Group B or Group C as defined by the Code, that may possess an angle of repose less than or equal to  $30^\circ$  are to comply with the requirements given hereinafter.

Depending on their schedule, these cargoes are the following:

- Ammonium nitrate, UN 1942
- Ammonium nitrate based fertilizers, UN 2067
- Ammonium nitrate based fertilizers, UN 2071
- Ammonium nitrate based fertilizers (non-hazardous)
- Ammonium sulphate
- Diammonium phosphate (d.a.p.)
- Potassium chloride
- Potassium nitrate, UN 1486
- Sodium nitrate and Potassium nitrate, mixture, UN 1499
- Superphosphate
- Urea
- Wood pellets.

### 4.2 Stability criteria

#### 4.2.1 (1/8/2011)

The stability verifications are to be performed according to the provisions applicable to the carriage of grain cargoes given in Pt E, Ch 4, Sec 3, [2.2]. The bulk density of the cargo is to be taken into account when determining the stability effect of free cargo surfaces.

### **4.3 Information to the Master**

#### **4.3.1** (1/8/2011)

Information regarding the stability is to be provided to the Master in the form of a separate booklet. As a minimum, the booklet is to contain the information listed in Pt E, Ch 4, Sec 3, [2.2.2].

### **4.4 Hull strength**

#### **4.4.1** (1/8/2011)

Where movable bulkheads are fitted, their scantlings are to be adequate to sustain the cargo induced loads, on the basis of the criteria in Part B, Chapter 7 or Part B, Chapter 8, as applicable depending on the ship length.

**SECTION 19****SHIP EFFICIENCY - EFFICIENT SHIP (S, DWT)****1 General****1.1 Application****1.1.1 (1/2/2014)**

The additional class notation **EFFICIENT SHIP (S, DWT)** is assigned, in accordance with Pt A, Ch 1, Sec 2, [6.14.28], to ships for which hull efficiency, propulsion and electrical power generation efficiency, at specified speed S and draft (corresponding to the DWT), is verified by the Society according to the requirements of this Section.

A Statement relevant to the above may be issued to ships, not classed with the Society, fulfilling the requirements of this Section.

**1.1.2 (1/12/2018)**

The ship is to be provided with the minimum propulsion power to maintain its manoeuvrability in accordance with IMO "2013 Interim guidelines for determining minimum propulsion power to maintain the manoeuvrability of ships in adverse conditions" (Resolution MEPC.232(65)).

This paragraph does not apply to supply vessels, however the Society reserves the right, in special cases, to require evidence that the ship has sufficient installed propulsion power to navigate and maintain the manoeuvrability in adverse conditions.

**1.1.3 (1/2/2014)**

The notation is not applicable to ship types for which the relevant reference curve in [4.2] is not defined.

**1.2 Documents to be submitted****1.2.1 (1/2/2014)**

The general list of plans and documents to be submitted is given in Tab 1. The Society reserves the right to request the submission of additional documents in the case of non-con-

ventional design or if it is deemed necessary for the evaluation of the systems and components.

**2 Reference conditions****2.1 General****2.1.1 (1/2/2014)**

The following reference conditions are to be considered:

- fuel normally used according to the ship specification or design
- electric users necessary for maintaining normal propulsion and habitable conditions (services for air conditioning, cargo related services, cargo handling, etc. are not included), see Pt C, Ch 2, Sec 1, [3.4.2]
- boiler in operation to sustain normal propulsion condition (if necessary), cargo services excluded
- operative speed (s)
- operative draft (DWT)
- trim as close as possible to that indicated in the ship's specification (in lack of information, even keel will be considered)
- wind and sea conditions as close as possible to those indicated in the specification.

**2.1.2 (1/2/2014)**

In case anyone of the reference conditions cannot be met during sea trials, special considerations are to be given to determine how much the results have been affected by the deviation from the reference conditions.

A technical report is to be submitted to the Society for evaluation and acceptance.

**2.1.3 (1/2/2014)**

Reference conditions reported in the sea trial test report will be maintained in the ship file or, in case of ship not classed by the Society, annexed to the statement referred to in

**Table 1 : Documentation to be submitted (1/2/2014)**

No.	I/A (1)	Document
1	I	Main engine and auxiliary engine type approval and EIAPP Certificates
2	I	NOx Technical File
3	A	Electric load balance
4	I	Technical reports according to [2.1.2]
5	A	Monitoring system block diagrams and electrical schemes
6	A	Monitoring system procedures
(1) A : to be submitted for approval, in four copies I : to be submitted for information, in duplicate.		

**2.1.4 (1/2/2014)**

The procedures to carry out the necessary tests and measurements are to be in line with the applicable MARPOL Annex VI requirements and relevant IMO Guidelines.

**3 Ship's engine efficiency****3.1 Main engine efficiency****3.1.1 (1/2/2014)**

For the purpose of this additional class notation, each main engine efficiency is evaluated taking also into consideration the fuel oil consumption due to auxiliary oil fired boiler and production of electrical power from auxiliary generating sets necessary to maintain ship's normal propulsion and habitable conditions.

The boiler fuel oil consumption  $F_B$  is to be measured when the boiler is used to maintain ship's normal propulsion and habitable conditions only: fuel oil consumption and relevant steam production necessary for other services (e.g. cargo heating, etc.) are not to be considered.

Main engine efficiency is evaluated as:

$$\eta_{ME1} = (3,6 \cdot 10^6) / (SFOC_{MEC} \cdot C_{ME})$$

where:

$$SFOC_{MEC} : SFOC_{ME} \cdot 1,1 + (F_B \cdot 1000 / (\sum_i P_{MEi} + P_{AEtot})) + SFOC_{AEC} \cdot P_{AE} / \sum_i P_{MEi} \cdot P_{ME} / \sum_i P_{MEi}$$

$SFOC_{ME}$  : main engine specific fuel oil consumption, in g/kWh, as indicated in the EIAPP technical file

$F_B$  : boiler measured fuel oil consumption, in kg/h, to maintain ship's normal propulsion and habitable conditions only

$\sum_i P_{MEi}$  : main engine(s) power needed to reach the operative speed, in kW

$P_{AEtot}$  : total electric power measured during testing, in kW

$$SFOC_{AEC} : SFOC_{AE} \cdot 1,1 + F_B \cdot 1000 / (\sum_i P_{MEi} + P_{AEtot})$$

$SFOC_{AE}$  : weighted average of auxiliary engine specific fuel oil consumptions, in g/kWh, as indicated in the EIAPP technical files

$P_{AE}$  : auxiliary engine power, in kW, necessary for maintaining normal propulsion (at the operative speed) and habitable conditions (services for air conditioning, cargo related services, cargo handling, etc. are not included), see Pt C, Ch 2, Sec 1, [3.4.2]

$C_{ME}$  : main engine fuel oil lower calorific value, in kJ/kg (to be assumed 42700 in lack of more detailed information)

**3.1.2 (1/2/2014)**

In case during sea trials means are available to measure the main engine fuel oil consumption, the main engine(s) efficiency is evaluated as:

$$\eta_{ME2} = 3600 \cdot P_{ME} / (F_{MEC} \cdot C_{ME})$$

where:

$P_{ME}$  : main engine power needed to reach the operative speed, in kW

$$F_{MEC} : F_{ME} + [F_B \cdot (P_{ME} + P_{AE} / N) / (\sum_i P_{MEi} + P_{AEtot})] + F_{AE} \cdot P_{AE} / P_{AEtot} \cdot P_{ME} / \sum_i P_{MEi}$$

$F_{ME}$  : main engine measured fuel oil consumption, in kg/h

$F_B$  : boiler measured fuel oil consumption, in kg/h, to maintain ship's normal propulsion and habitable conditions only

$P_{AE}$  : auxiliary engine power, in kW, necessary for maintaining normal propulsion (at the operative speed) and habitable conditions (services for air conditioning, cargo related services, cargo handling, etc. are not included), see Pt C, Ch 2, Sec 1, [3.4.2]

$N$  : number of main engines

$P_{AEtot}$  : total electric power measured during testing, in kW

$F_{AE}$  : total auxiliary engine measured fuel oil consumption, in kg/h

$C_{ME}$  : main engine fuel oil lower calorific value, in kJ/kg (to be assumed 42700 in lack of more detailed information)

**3.2 Auxiliary engine efficiency****3.2.1 (1/2/2014)**

In general, for the purpose of this additional class notation, the auxiliary engine efficiency is evaluated as:

$$\eta_{AE1} = (3,6 \cdot 10^6) / (SFOC_{AEC} \cdot C_{AE})$$

where:

$$SFOC_{AEC} : SFOC_{AE} \cdot 1,1 + F_B \cdot 1000 / (\sum_i P_{MEi} + P_{AEtot})$$

$SFOC_{AE}$  : weighted average of auxiliary engine specific fuel oil consumption, in g/kWh, as indicated in the EIAPP technical files

$F_B$  : boiler measured fuel oil consumption, in kg/h, to maintain ship's normal propulsion and habitable conditions only

$\sum_i P_{MEi}$  : main engine(s) power needed to reach the operative speed, in kW

$P_{AEtot}$  : total electric power measured during testing, in kW

$C_{AE}$  : auxiliary engine fuel oil lower calorific value, in kJ/kg (to be assumed 42700 in lack of more detailed information)

**3.2.2 (1/2/2014)**

In case during sea trials means are available to measure the auxiliary engine fuel oil consumption, the auxiliary engine efficiency is evaluated as:

$$\eta_{AE2} = 3600 \cdot P_{AEtot} / (F_{AEC} \cdot C_{AE})$$

where:

$P_{AEtot}$  : total electric power measured during testing, in kW

$$F_{AEC} : F_{AE} + F_B \cdot P_{AEtot} / (\sum_i P_{MEi} + P_{AEtot})$$

$F_{AE}$  : total auxiliary engine measured fuel oil consumption, in kg/h

$F_B$  : boiler measured fuel oil consumption, to maintain ship's normal propulsion and habitable conditions only, in kg/h

$\Sigma_i P_{MEi}$  : main engine(s) power needed to reach the operative speed, in kW

### 3.3 Calculation of the efficiency of the ship's engines

#### 3.3.1 (1/2/2014)

The efficiency of the ship's engines is evaluated according to the following:

$$\eta_{E1} = \Sigma_j [ \eta_{ME1j} \cdot P_{MEj} / (\Sigma_j P_{MEj} + P_{AEtot}) ] + \eta_{AE1} \cdot P_{AEtot} / (\Sigma_i P_{MEi} + P_{AEtot})$$

or in case during sea trials means are available to measure fuel oil consumption as indicated in [3.1] and [3.2]:

$$\eta_{E2} = \Sigma_j [ \eta_{ME2j} \cdot P_{MEj} / (\Sigma_j P_{MEj} + P_{AEtot}) ] + \eta_{AE2} \cdot P_{AEtot} / (\Sigma_i P_{MEi} + P_{AEtot})$$

$\eta_E$ , efficiency of the ship's engines, is the maximum between  $\eta_{E1}$  and  $\eta_{E2}$ .

## 4 Consumption and working capability

### 4.1 Ratio based on operative values

#### 4.1.1 (1/2/2014)

The following ratio, based on operative values is defined

$$R = F_{tot} \cdot 10^3 / (S \cdot W_{CAP})$$

where:

$F_{tot}$  : measured total fuel oil consumption in the reference conditions given in [2.1.1], in kg/h

$S$  : speed in the reference conditions, in knots

$W_{CAP}$  : ship's working capability in the reference conditions depending on ship type.

### 4.2 Reference curves for specific ship types

#### 4.2.1 (1/2/2014)

The reference curves are defined in Tab 2.

## 5 Monitoring system

### 5.1 General

#### 5.1.1 (1/2/2014)

A system capable of monitoring at least engine power and fuel oil consumption is to be implemented onboard. The purpose of monitoring system is to provide information about the modifications of the original ship's efficiency level.

### 5.2 Measurements

#### 5.2.1 (1/2/2014)

The monitoring system is to ensure an automatic measurement of the torque or of the engine power.

The measurement of the engine fuel oil consumption may be based on the acquisition of data from sensors or from a periodic stocktakes of fuel tanks according to a procedure previously examined and accepted by the Society.

## 6 Criteria for assignment

### 6.1 General

#### 6.1.1 (1/12/2018)

The additional class notation **EFFICIENT SHIP (S, DWT)** is assigned to ships having:

- an efficiency of the ship's engines
  - $\eta_E \geq 0,450$  for ships having four stroke main engine(s),
  - $\eta_E \geq 0,475$  for ships having two stroke main engine(s), and
  - $\eta_E > 0,350$  for supply vessels having four stroke main engine(s)
- a R value below the reference curve applicable to the specific ship type as given in [4.2] at the reference speed (S) and deadweight (DWT)
- a monitoring system according to item [5].

**Table 2 (1/12/2018)**

Ship type	Reference curve	Ship's working capability
Tanker	$304 \cdot W_{CAP}^{-0,488}$	Deadweight (1)
Gas carrier	$315 \cdot W_{CAP}^{-0,456}$	Deadweight (1)
Bulk carrier	$240 \cdot W_{CAP}^{-0,477}$	Deadweight (1)
General cargo ship	$31 \cdot W_{CAP}^{-0,216}$	Deadweight (1)
Container ship	$50 \cdot W_{CAP}^{-0,201}$	Deadweight (1)
Refrigerated cargo carrier	$64 \cdot W_{CAP}^{-0,244}$	Deadweight (1)
Combination carrier	$342 \cdot W_{CAP}^{-0,488}$	Deadweight (1)
Supply vessel	$4038 \cdot W_{CAP}^{-0,647}$	Deadweight (1)

(1) This value is the DWT parameter which is indicated between brackets in the additional class notation, see [1.1.1].



## SECTION 20

# NAVIGATION SURROUNDING THE ARABIAN PENINSULA (SAHARA)

### 1 General

#### 1.1 Purpose and application

##### 1.1.1 (1/7/2014)

The additional class notations ( **SAHARA** and **SAHARA** are assigned, in accordance with Pt A, Ch 1, Sec 2, [6.14.31], to ships complying with the requirements of this Section, intended to operate in the areas surrounding the Arabian Peninsula:

- Arabian Gulf
- Oman Gulf
- Red Sea
- Arabian Sea along the South-East Coast of the Arabian Peninsula.

The additional class notation ( **SAHARA** is assigned to ships with unrestricted navigation notation.

The additional class notation **SAHARA** is assigned to ships for which navigation in the Arabian Sea along the South-East Coast of the Arabian Peninsula is limited to sea states with significant wave height not greater than 2 meters and intended to operate only within 50 nautical miles from the shore. For these ships, according to Pt A, Ch 1, Sec 2, [5.2.6] the navigation notation **special (Arabian Peninsula)** is assigned and the specific restrictions (wave height, operating distance from the shore or any specific operating area) are to be indicated.

#### 1.2 Required notations

##### 1.2.1 (1/7/2014)

In order to grant the notation ( **SAHARA** or **SAHARA**, the ship is to be assigned the additional class notations:

- **HELIDECK** or **HELIDECK-H**, see Sec 16, if the ship is fitted with helicopter facilities i.e. platforms specifically built for the landing of helicopters or areas of open decks intended for the same purpose;
- **DIVINGSUPPORT**, see Sec 14, for ships equipped with a certified diving system;
- **STRENGTHBOTTOM**, see Sec 1, for units with service notation dredger, barge or pontoon;
- **GRABLOADING**, see Sec 2, if the ship is intended to load/unload cargoes using buckets or grabs;
- **COMF-AIR** (both W and S) notation, according to Ch 6, Sec 3 and the design criteria given in [4.1].

### 2 Hull and Stability

#### 2.1 Design Loads

##### 2.1.1 Navigation Coefficients (1/7/2014)

If the navigation notation **special (Arabian Peninsula)** is assigned, the values of navigation coefficients (refer to Pt B, Ch 5, Sec 1, [2.6]) are defined in Tab 1.

**Table 1 : Navigation coefficients (1/7/2014)**

Navigation notation	Navigation coefficient n	Navigation coefficient n <sub>1</sub>
<b>special (Arabian Peninsula)</b>	0,8	0,9

#### 2.2 Deck

##### 2.2.1 Timber deck board (1/7/2014)

For ships with notation ( **SAHARA** or **SAHARA** and having one of the service notations supply vessel, tug or pontoon, the deck is to be protected by wood sheeting according to the requirements in Pt B, Ch 11, Sec 1, [5].

### 3 Machinery

#### 3.1 Cooling systems

##### 3.1.1 Maximum temperature (1/7/2014)

For ships with the notation ( **SAHARA** or **SAHARA**, the design of all the cooling systems according to Pt C, Ch 1, Sec 10, [10], is to be carried out according to the maximum temperatures specified in Tab 2, instead of those specified in Pt C, Ch 1, Sec 1, [2.5.1], while the same minimum temperature values are to be used.

**Table 2 : Air and water maximum temperatures for the design of the cooling systems (1/7/2014)**

AIR TEMPERATURE	
Location, arrangement	Maximum Temperature (°C)
In enclosed spaces or on exposed decks	+50
WATER TEMPERATURE	
Coolant	Maximum Temperature (°C)
Sea Water	+37

## 3.2 Bearings

### 3.2.1 Grease lubricated bearings (1/7/2014)

For ships with the notation ( SAHARA or SAHARA, the grease used in grease lubricated bearings is to be selected taking into account the value of air temperature on machinery components specified in Tab 2.

## 3.3 Boiler feed water and fresh water systems

### 3.3.1 Sea water salinity (1/7/2014)

For ships with the notation ( SAHARA or SAHARA, in the design of boiler feed water and fresh water production systems, the maximum salinity content of the sea water is to be taken as 57 g/litre.

## 4 Comfort with regard to climate

### 4.1 Design criteria

#### 4.1.1 Air design temperature (1/7/2014)

The design outside air temperature is to be taken as follows:

- WINTER: not greater than -5 °C, for the ( SAHARA notation, not greater than +10 °C for the SAHARA notation
- SUMMER: not less than +50 °C.

The design inside air temperatures are given in Ch 6, Sec 3, [3.2].

#### 4.1.2 Sea water design temperature (1/7/2014)

The design sea water temperature is to be taken as follows:

- WINTER: not greater than -2 °C, for the ( SAHARA notation, not greater than +10 °C for the SAHARA notation
- SUMMER: not less than +37 °C.

#### 4.1.3 Humidity (1/7/2014)

The design outside relative humidity in summer is to be taken as not less than 95%.

The design inside relative humidity in winter and in summer is to be in accordance with Ch 6, Sec 3, [3.2.5], however in any case it is to be not less than 30% and not greater than 60%.

## 4.2 Ventilation

### 4.2.1 Filters (1/7/2014)

The air filters are to be:

- effective in capturing the sand that may be present in air taken from outside
- particularly easy to clean or replace due to the more frequent servicing required in a sandy environment.

## 4.3 Calculations of heat gains and losses

### 4.3.1 Sun radiance (1/7/2014)

The sun radiance input data to be used in heat gain and loss design calculations are to explicitly take into account also the most severe regional values of the Arabian Peninsula.

## 5 Electrical installations

### 5.1 Ambient air and sea water temperatures

#### 5.1.1 (1/7/2014)

For ships with the notation ( SAHARA or SAHARA, the ambient air and sea water temperature maximum values in Tab 3 are applicable as design ones for electrical installations instead of those specified in Pt C, Ch 2, Sec 2, [1.2] and [1.4], while the same minimum temperature values are to be used.

The ambient air maximum value depends also on the specific location of installation.

**Table 3 : Air and water maximum temperatures for the design of the electrical installations (1/7/2014)**

AIR TEMPERATURE	
Location, arrangement	Maximum Temperature (°C)
In enclosed spaces	+50
Inside consoles or fitted on combustion engines and similar	+60
On exposed decks	+50
WATER TEMPERATURE	
Coolant	Maximum Temperature (°C)
Sea Water	+37

#### 5.1.2 (1/7/2014)

Where electrical equipment is installed within environmentally controlled spaces, the ambient temperature for which the equipment is to be suitable may be reduced from 50°C and maintained at a value not less than 35°C provided that:

- the equipment is not used for emergency services
- temperature control is achieved by at least two cooling units so arranged that in the event of loss of one cooling unit, for any reason, the remaining unit(s) is (are) capable of satisfactorily maintaining the design temperature
- the equipment is able to be initially set to work safely up to a 50°C ambient temperature until such time as the lower ambient temperature is achieved; the cooling equipment is to be rated for a 50°C ambient temperature
- audible and visual alarms are fitted, at a continually manned control station, to indicate any malfunction of the cooling units.

#### 5.1.3 (1/7/2014)

In accepting an ambient temperature less than 50° it is to be ensured that electrical cables are adequately rated throughout their length for the maximum ambient temperature to which they are exposed.

#### 5.1.4 (1/7/2014)

The equipment used for cooling and maintaining the lower ambient temperature is to be classified for a secondary essential service.

## 5.2 Humidity

### 5.2.1 (1/7/2014)

For ships with the notation ( **SAHARA** or **SAHARA**, the humidity values as shown in Tab 4 are applicable as design ones for electrical installations instead of those specified in Pt C, Ch 2, Sec 2, [1.3] in relation to the specific location of installation.

## 6 Automation

### 6.1 Hardware type approval

#### 6.1.1 (1/7/2014)

For ships with the notation ( **SAHARA** or **SAHARA**, the dry heat test according to the procedure described in IEC Publi-

cation 60068-2-2, as specified in Pt C, Ch 3, Sec 6, Tab 1, is to be carried out for the following temperatures:

- 60°C ± 2 °C for a duration of 16 hours, or
- 75°C ± 2 °C for a duration of 2 hours.

Equipment to be mounted in consoles, housing etc. together with other equipment are to be tested at 75°C. All the other requirements for automation system testing as in Pt C, Ch 3, Sec 6 are applicable.

**Table 4 : Humidity values for the design of electrical installations (1/7/2014)**

Humidity	
Location	Maximum Humidity
General	95% at + 60°C
Air-conditioned areas	Specific values are to be considered on a case by case basis

## SECTION 21

## MOORING (ANCHORING)

### 1 Application

#### 1.1 General

##### 1.1.1 (1/7/2014)

The additional class notation **MOORING** is assigned to units provided with arrangements for permanent mooring (anchoring) at a certain location.

##### 1.1.2 (1/7/2014)

The structural requirements of this Section apply to devices pertaining to the mooring system which are dedicated to the mooring function and are involved in the transmission of mooring loads. Such structures are located between the sea bed foundations (excluded) and the structural reinforcements or the mooring equipment (included), depending on the arrangement of the mooring system, interfacing with the unit and the mooring system itself. Other types of mooring systems not covered by the present Section are specially considered.

### 2 Structure design principles

#### 2.1 General

##### 2.1.1 (1/7/2014)

- a) A mooring system is to be designed so as to minimize its sensitivity to environmental factors and to operational demands and so as to make its construction and inspection easier.
- b) The design of the mooring system as a whole and of its components is to be such as to avoid that normal operational conditions be adversely affected by vibrations of structures.
- c) Mechanical components are to be designed in compliance with international recognized Codes and Standards.
- d) Supplementary Codes or Standards used for the design of the mooring system are to be previously submitted to the Society for approval.
- e) Secondary structures such as fenders, gangway ladders, mooring eye-bolts, etc. are to be designed such as to avoid that their possible failure, due to accidental overloading, may result in damage to primary structures of the mooring system and to personnel.
- f) Connections and structural joints are to be designed so as to avoid, as far as practicable, complex structures and sharp section variations which may give rise to dangerous stress concentrations. The transfer of normal tensile stresses through the plate thickness is also to be avoided as far as practicable.
- g) Mooring systems constructed to operate in locations where extremely low ambient temperatures may be

encountered are to be designed by adopting solutions such as to minimize ice accumulation on structures and machinery.

- h) Buoys and buoyant devices in general are to be adequately compartmented by watertight divisions in order to have sufficient stability.

#### 2.2 General

##### 2.2.1 (1/7/2014)

Material grades of the mooring system are to be in compliance with Pt B, Ch 4, Sec 1; structural categories and material Classes are to be applied in connection with Tab 1 and [2.2.2].

**Table 1 : Application of material classes and grades in mooring systems (1/7/2014)**

Structural member category	Material Class
SECONDARY	I
PRIMARY	II
SPECIAL	III

##### 2.2.2 (1/7/2014)

The following categorization applies to structural members of the mooring system.

SECONDARY members:

- walkways
- guard rails
- minor fittings and attachments

PRIMARY members:

- swivel gantry support structure
- chain tables
- anchor line fairleads and chain stoppers and their supporting structures
- heavy substructures and equipment supports

SPECIAL members:

- structures in way of critical load transfer points which are designed to receive major concentrated loads in way of mooring systems, including yokes and similar structures, and supports to hawsers of mooring installations including external hinges, complex padeyes, brackets and supporting structures
- intersections of structures which incorporate novel construction including the use of steel castings
- highly stressed structural elements of anchor-line attachments.

**2.2.3 (1/7/2014)**

Chains are to be of offshore Grades R3, R3S, R4, R4S and R5 and are to comply with the "Rules for the Classification of Floating Offshore Units at Fixed Locations and Mobile Offshore Drilling Units" Pt D, Ch 4, Sec 1, [2.1.2].

**3 Design loads****3.1 General****3.1.1 (1/7/2014)**

The following loads are to be considered for the scantlings of the mooring system, as appropriate:

- mooring loads arising from the mooring analysis described in App 2. The maximum values from the dynamic analysis are to be adopted for the final design of the system; quasi static loads may be adopted for early design scope;
- local static and dynamic sea pressures, defined in accordance with Pt B, Ch 5, Sec 5;
- gravity loads and internal forces, as defined in Pt B, Ch 5, Sec 6;
- hull girder loads, as defined in Pt B, Ch 5, Sec 2, where applicable for the scantlings of structures in main hull constituting the interface with the mooring system;
- design loads are to be applied in the worst combination to which the system may be subjected during the life of the unit, including transit.

Due account is to be given to wave slamming and accidental loads, like impact with floating objects (ice blocks, etc.).

Proper cyclic loads, corresponding to dynamic components of applicable loads are to be accounted for where fatigue analysis is required, on a case by case basis.

**4 Scantlings****4.1 General****4.1.1 (1/7/2014)**

The structural checks to be carried out in general for the verification of structural scantlings of mooring systems and their attachment to the unit are yielding, buckling and fatigue checks.

**4.1.2 (1/7/2014)**

Due consideration is to be given to the detail design in fatigue sensitive areas including structural supports in way of bearings and highly stressed structural elements of mooring line attachments, chain stoppers and supporting structures, mooring arms, articulated and sliding joints.

**4.2 Net scantlings****4.2.1 Anchor lines (1/7/2014)**

Scantling assessment of anchor lines is to be based on net values. The values of corrosion margins based on current industry standards (refer for example to API RP 2SK) may be adopted and applied to anchor lines with respect to the service life of the installation.

**5 Protection against corrosion****5.1 General****5.1.1 (1/7/2014)**

Provisions for protection against corrosion of the mooring system are given Pt B, Ch 11, Sec 1.

For permanent systems, corrosion of wire ropes at connection to sockets is to be prevented: it is recommended that either the wire be electrically isolated from the socket or that the socket be isolated from the adjacent component.

## SECTION 22

## INDOOR AIR QUALITY MONITORING (AIR MON)

### 1 General

#### 1.1 Application

##### 1.1.1 (1/7/2015)

The additional class notation **AIR MON** is assigned, in accordance with Pt A, Ch 1, Sec 2, [6.14.33], to ships for which an air quality management system is implemented and verified by the Society according to the requirements of this section.

A Statement relevant to the above may be issued to ships, not classed with the Society, fulfilling the requirements of this section.

#### 1.2 Basic principles

##### 1.2.1 (1/7/2015)

The Indoor Air Quality refers to air quality in closed or semi-enclosed spaces within the ship and it depends on various factors: microbial contaminants (mould, bacteria), particulates, gases (i.e. carbon monoxide and dioxide, volatile organic compounds, ozone, nitrogen oxides, etc.), asbestos and any other element that can induce adverse health conditions.

Noise, lighting, humidity and other physical pollutants are outside the scope of this notation.

##### 1.2.2 (1/7/2015)

The requirements of this Section define the management system to ensure indoor air quality on board, the methods for verification of compliance and the criteria for acceptance.

### 2 Definitions and acronym

#### 2.1

##### 2.1.1 (1/7/2015)

HVAC: Heating, Ventilation and Air-Conditioning.

### 3 Documentation to be submitted

#### 3.1

##### 3.1.1 (1/7/2015)

Before the survey for the assignment of the notation is carried out, and in the case of any important change in the ship's internal spaces or HVAC system, the following documentation is to be submitted for information:

- general description of the maintenance and monitoring activities on the HVAC system
- list of relevant internal procedures and plans ( Note 1)
- list of pollutants to be analyzed

The Society reserves the right to request the submission of additional documents, if deemed necessary, for the evaluation of the company's implemented system.

Note 1:

- procedures for the maintenance of the HVAC system
- monitoring plan of the microbial contaminants, particulates and mapping of asbestos
- procedure stating limit values for each pollutant, reference standards, actions to be taken if the defined limits are exceeded
- procedure detailing the instructions for sampling, shipment and analysis of each element to be analyzed by the laboratories.

### 4 Requirements

#### 4.1 General

##### 4.1.1 Inspection and maintenance (1/7/2015)

Maintenance of the system is to be carried out regularly in accordance with the maker's instructions and internal procedures. These procedures have to include maintenance planning, the definition of responsibilities and, depending on the equipment, the personnel required skills.

A plan of periodical (at least biannual) visual inspections of the HVAC system is to be implemented in order to verify the cleanliness status and absence of dust and dirt.

The plan is to describe the list of points to be inspected and the people in charge.

The reports of maintenance activities and inspections are to be maintained for at least three years, and are to be made available, upon Surveyor request, during the survey for the assignment of the notation and subsequent surveys.

##### 4.1.2 Monitoring (1/7/2015)

An annual monitoring plan of the microbial contaminants (e.g. mould, total bacteria count and legionella) and particulates is to be implemented by a skilled technician.

A technician is considered skilled in this activity after at least one year of experience.

The plan is to detail, for each pollutant (microbial contaminants and particulates), the sample points and relevant frequency.

If the ship is not asbestos free, a mapping of asbestos is to be carried out and the presence of airborne asbestos fibre is to be monitored in each area.

Monitoring of the airborne asbestos fibre concentrations is to be carried out:

- every 3 years in the area where asbestos is declared to be present;
- after any work involving elements containing asbestos. In this case, monitoring is to be carried out only in the areas concerned.

The monitoring of gases that can induce adverse health conditions is not required on condition that there are no technical reasons to suspect their presence in the indoor air.

At the discretion of the Society, additional analyses may be carried out.

#### **4.1.3 Actions (1/7/2015)**

Limit values for each element, reference standards and the actions to be taken if the defined limits are exceeded are to be identified and listed in a procedure.

If the defined limits are exceeded, a new analysis following the corrective action taken is to be carried out.

A person responsible for the collection and evaluation of laboratory reports, as well as for defining and implementing the corrective actions, when needed, is to be defined.

If limits are exceeded or a health problem due to air occurs on board, the person responsible is to contact the Society that reserves the right to suspend the notation.

The management of medical emergencies is outside the scope of this notation.

## **4.2 Operational requirements**

### **4.2.1 Sampling and analysis (1/7/2015)**

An internal procedure is to be implemented, detailing the instructions for sampling, shipment and analysis of each element.

The procedure is to contain, as a minimum, the following concepts.

The samplings and analysis are to be carried out by qualified technicians and in accordance with international standards.

Qualified technicians means people trained for this purpose, having at least two years' experience in this activity.

The shipment is to guarantee the sample integrity (i.e. temperature, perishability time, protection from light, contamination, knocks, etc.) during its transport to the laboratory.

The laboratory is to be certified in accordance with the edition of standard ISO/IEC 17025 in force.

A (not exhaustive) list of recognized standards for sampling and analyses is offered for reference purposes.

ISO 16000 series, ISO 11731 series, ISO 8199, ISO 7218, ISO/TS 12869, ISO/TS 11133, ISO/TR 13843, EN 13098, EN 14583:2004; and National Air Duct Cleaners Association (NADCA) standard - Assessment, Cleaning and Restoration of HVAC Systems.

### **4.2.2 Acceptable values and report (1/7/2015)**

For the purpose of this notation, the acceptable values of each pollutant are to be in accordance with international standards of recognized organizations such as ISO (International Organization for Standardization), CEN (European Committee for Standardization), WHO (World Health Organization), NIOSH (National Institute for Occupational Safety and Health), NADCA (National Air Duct Cleaners Association).

The laboratory report is to state:

- the standards followed for sampling and analyses,
- the values identified,
- date
- signature of the technician.

The reports are to be maintained for at least three years and are to be made available, upon Surveyor request, during the survey for the assignment of the notation and subsequent surveys.

## **5 Assignment criteria**

### **5.1**

#### **5.1.1 (1/7/2015)**

The additional class notation **AIR MON** is assigned to ships or new buildings upon verification of the availability of the required procedures and analysis reports required by [4.1] and [4.2].

## SECTION 23

## DEDICATED OIL RECOVERY SYSTEM (DORS)

### 1 General

#### 1.1 Application

##### 1.1.1 (15/7/2015)

The additional class notation **DORS** is assigned to ships with cargo tanks and fuel oil tanks provided with two or more connectors in order to allow the recovery of the content of the tanks by one of or both the following methods:

- injecting the sea water through one connector and recovering the tank content from another, or
- introducing a submersible pump into the tank through one of the connectors. In this case, vacuum inside the tank is to be avoided with appropriate means.

For ships assigned with the additional class notation **DORS**, the aforesaid connectors are to be used only to recover the content of the tanks following a casualty.

##### 1.1.2 (15/7/2015)

When the connectors are intended to be also used during the normal service of the ship, in accordance with [3.2], the additional class notation **DORS-NS** is assigned.

#### 1.2 Definition

##### 1.2.1 Cargo (15/7/2015)

"Cargo" is a liquid cargo carried in bulk in an oil tanker as defined in SOLAS Regulation II-1/2.22, or in a chemical tanker as defined in SOLAS Regulation II-1/3.19.

##### 1.2.2 Cargo tank (15/7/2015)

"Cargo Tank" is a tank in which cargo as defined in [1.2.1] is carried. Slop tanks are included.

##### 1.2.3 Fuel oil (15/7/2015)

"Fuel oil" is any oil used in connection with the propulsion and auxiliary machinery of the ship in which such oil is carried. Oil residues (sludge) and oily bilge water are not to be considered as fuel oil.

##### 1.2.4 Fuel oil tank (15/7/2015)

"Fuel oil Tank" is a tank in which fuel oil is carried, excluding those tanks which do not contain fuel oil in normal conditions, such as overflow tanks.

##### 1.2.5 Tank (15/7/2015)

For the purpose of **DORS** notation, "Tank" is intended either as a fuel oil tank or a cargo tank.

##### 1.2.6 Connector (15/7/2015)

"Connector" is a pipe section fitted with a flange sealed by a blind flange. It is to be:

- a "Tee" pipe section inserted in a piping system connected to the tank top and which cannot be isolated from the tank,
- a dedicated pipe section directly connected to the tank, which may extend below the tank top plating.

##### 1.2.7 Dedicated oil recovery system (15/7/2015)

The fast dedicated oil recovery system is a set of connectors designed and arranged in accordance with the requirements of this Section.

#### 1.3 Documents to be submitted

##### 1.3.1 (15/7/2015)

The plans and documents to be submitted are listed in Tab 1.

##### 1.3.2 (15/7/2015)

Procedures for installation, use and maintenance of the connectors are to be submitted for information.

**Table 1 : Documents to be submitted (15/7/2015)**

Item n°	I/A (1)	Documents
1	I	List of cargo tanks and fuel oil tanks with their capacity and possible connectors fitted
2	A	Connector drawings, indicating of wall thickness, material and coating
3	A	Calculation of the maximum allowable flow rate, when the additional notation <b>DORS-NS</b> is assigned to the ship
4	I	Damage Control Plan with indication of the location and characteristics (type and dimensions) of connectors
(1)	I:	to be submitted for information
	A:	to be submitted for approval



## 2 Requirements for the design and installation of the connectors

### 2.1 General

#### 2.1.1 (15/7/2015)

The following tanks are to be fitted with connectors:

- a) all cargo tanks, irrespective of the capacity
- b) fuel oil tanks having a capacity more than 30 m<sup>3</sup> when the overall fuel oil capacity of the ship is less than 600 m<sup>3</sup>
- c) fuel oil tanks having a capacity more than the 5% of the overall fuel oil capacity when that capacity is of 600 m<sup>3</sup> or more.

#### 2.1.2 (15/7/2015)

All the applicable provisions of the Rules are to be applied, unless otherwise specified, in the design and installation of connectors. In particular, connectors are not to hamper the safe operation of the piping arrangement of the tanks where they are fitted (in particular the air pipe automatic closing devices), are not to reduce the transverse internal area of the concerned pipe line and are not to result in an increase of pressure or vacuum in any tank that may cause its design conditions to be exceeded.

### 2.2 Arrangement

#### 2.2.1 Fitting of the connectors (15/7/2015)

For the installation of the connectors, any of the piping system fitted on the tank may be used, if compliant with [2.3]. Connectors fitted to the tank top are to be connected to the tank top plating or, alternatively, to a removable access cover.

#### 2.2.2 Geometrical characteristics (15/7/2015)

The way connectors are shaped and installed (pipe line bending radius included) is to be defined by the designer, provided they comply with [2.1] to [2.3].

If the connector is intended for the introduction of a submersible pump into the tank, the bending radius of the concerned pipe line is to allow for the unhampered passage of the pump.

#### 2.2.3 Access (15/7/2015)

Easy access is to be guaranteed in way of each connector, by means of a clear area around it.

The connector locations and the minimum spaces all around each connector are to be defined by the designer.

#### 2.2.4 Name plates and warning plates (15/7/2015)

Each connector must be fitted with:

- a) A name plate giving the following information:
  - Identification of the tank with its volume and type of content
  - Utilization of the connector (water injection, oil recovery, introduction of a submersible pump)
  - Distance between the connector flange and the lowest allowable position of the submersible pump, where applicable
  - Value of the maximum flow rate allowed for the connector in case of **-NS** additional notation.
- b) A warning plate indicating that the connector is not to be used during the normal operation of the ship, except if the notation **-NS** is assigned.

### 2.3 Design

#### 2.3.1 Number of connectors (15/7/2015)

The number of connectors is to be chosen in accordance with the design flow rate necessary to empty the relevant tanks, as recommended by the designer of the fast oil recovery system. In any case, at least two connectors are to be provided on every one of such tanks. If tanks are interconnected, common connectors may be used.

#### 2.3.2 Materials (15/7/2015)

Materials used for the connectors and gaskets are to comply with the relevant provision of Pt C, Ch 1, Sec 10, [2.2] and are to be suitable for the characteristics of the concerned fluids.

#### 2.3.3 Thickness (15/7/2015)

The thickness of the connectors is not to be less than:

- the minimum value indicated in the Pt C, Ch 1, Sec 10, [2.2] if the connector is fitted to the tank, or
- that of the adjacent pipe if the connector is fitted to a pipe.

#### 2.3.4 Flanges (15/7/2015)

The dimensions of connector flanges, counter-flanges and relative bolts are to be chosen in accordance with recognized standards.

#### 2.3.5 Supporting of the connectors (15/7/2015)

If means of support are fitted, Pt C, Ch 1, Sec 10, [9.1.9] apply.

#### 2.3.6 Prevention of progressive flooding (15/7/2015)

Connector pipes are to comply with in Pt C, Ch 1, Sec 10, [5.5].

## 3 Additional requirements for **-NS** notation

### 3.1 General

#### 3.1.1 (15/7/2015)

These provisions apply to ships that require the additional notation **-NS**.

### 3.2 Requirements

#### 3.2.1 (15/7/2015)

The additional class notation **DORS-NS** is assigned when the connectors are intended to be also used during the normal service of the ship, in accordance with [1.1.2].

#### 3.2.2 Maximum allowable flow rate (15/7/2015)

The maximum allowable flow rate is to be calculated for each connector. For this purpose, the designer is to take into account, among other things, the characteristics of the air pipe automatic closing devices, if any, which are to be of a type approved by the Society for the worst expected conditions. Refer to Pt C, Ch 1, Sec 10, [9.1.6] and Pt C, Ch 1, Sec 10, [21.2.2].

## SECTION 24

## LNG READY (X1, X2, X3...) AND CNG READY (X1, X2, X3...)

### 1 General

#### 1.1 Application

##### 1.1.1 (1/1/2023)

The additional class notation **LNG READY (X1, X2, X3...)** or **CNG READY (X1, X2, X3...)** is assigned, in accordance with Pt A, Ch 1, Sec 2, [6.14.37]), to ships fulfilling the requirements of this section.

A Certificate of Compliance may be issued to ships not classed with the Society, fulfilling the requirements of this section.

### 2 Assignment criteria

#### 2.1

##### 2.1.1 (1/1/2023)

The additional class notation **LNG READY (X1, X2, X3 ...)** or **CNG READY (X1, X2, X3 ...)** is assigned:

- a) to new buildings, other than LNG carriers, that are in accordance with the Tasneef Rules in force at the date when the contract for construction between the Owner and the shipbuilder is signed;
- b) to existing ships, other than LNG carriers, that are in accordance with the Tasneef Rules in force at the date of request of notation assignment.

having the following characteristics:

- Design (X1); and
- One of the following:
  - Structure (X2);
  - Tank (X3);
  - Piping (X4);
  - Users (X5).

The notation characteristics (**X1, X2, X3...**) are defined in Tab 1.

Irrespective of previous assignment of the **LNG READY** or **CNG READY** notation, when the ship will be converted in gas fuelled ship, approval for compliance with the Statutory and Tasneef requirements in force at the time of conversion, followed by testing and commissioning under survey, will be required.

**Table 1 : Description of the notation characteristics (1/1/2023)**

X <sub>i</sub>	Characteristic	Description
1	Design	The complete design of the ship with gas fuelled system is found to be in compliance with the rules applicable to new buildings, including those for the <b>LNG FUELLED</b> or <b>CNG FUELLED</b> notation (ref. Pt C, Ch 1, App 7)
2	Structure	Structural reinforcements to support the fuel containment system (LNG fuel tank(s)) are installed and materials to support the relevant temperatures are used.
3	Tank	Gas storage tank, tank master isolation valve, fuel venting arrangements and, where applicable, the fuel storage hold space, structural fire protection and ventilation arrangements for under deck tank locations are built under survey and installed in accordance with approved drawings and certified fit for gas fuel operations.
4	Piping	All piping equipment associated with the gas fuelled system, e.g. pipes, pumps, valves, etc. including all bunkering arrangements and associated access arrangements including structural fire protection as applicable, are built and installed in accordance with approved drawings and certified fit for gas fuel operations

X <sub>i</sub>	Characteristic	Description
5	Users	Engineering systems are installed in accordance with approved drawings and certified fit for using gas as fuel or ready to be retrofitted: <ul style="list-style-type: none"> <li>• ME<sub>rr</sub>: Main engine(s) installed can be converted to dual fuel engines;</li> <li>• ME<sub>df</sub>: Main engine(s) installed are dual fuel engines;</li> <li>• AE<sub>rr</sub>: Auxiliary engines installed can be converted to dual fuel engines (see Note 1);</li> <li>• AE<sub>df</sub>: Auxiliary engines installed are dual fuel engines (see Note 1);</li> <li>• B<sub>rr</sub>: Boilers installed can be converted to dual fuel;</li> <li>• B<sub>df</sub>: Boilers installed can be operated on gas fuel.</li> </ul>
<p>Note 1: The capacity of the converted auxiliary engines is to be sufficient for the ship power balance.</p> <p>Examples:</p> <ul style="list-style-type: none"> <li>• LNG READY (Design, Users(ME<sub>rr</sub>)) means that the future LNG fuelled design has been examined and found in compliance with the applicable rules and the ship main engine is of a type that can be converted to dual fuel engine;</li> <li>• LNG READY (Design, Structure, Users(ME<sub>rr</sub>, AE<sub>rr</sub>)) means that the future LNG fuelled design has been examined and found in compliance with the applicable rules, the ship is constructed with the necessary structural reinforcement and low temperature materials around the LNG fuel tank(s), and the main and auxiliary engines are of types that can be converted to dual fuel engines.</li> </ul>		

### 3 Documents to be submitted

deemed necessary for the evaluation of the systems and components.

#### 3.1 Documentation requirements for characteristic "Design"

##### 3.1.1 (1/1/2023)

The list of plans and documents to be submitted is given in Tab 2.

The documentation is to be marked "LNG ready" or "CNG ready" in each drawing title.

The Society reserves the right to require additional documents in the case of non-conventional design or if it is

#### 3.2 Documentation requirements for characteristics "Structure", "Tank", "Piping", "Users"

##### 3.2.1 (1/10/2015)

The design, applicable to the assigned characteristic, is to be submitted and approved for compliance with the applicable sections of Pt C, Ch 1, App 7.

**Table 2 : Documents to be submitted (1/10/2015)**

Item n°	Documentation	Additional description
1	General arrangement	Including LNG tank location with distances from ship side, adjacent spaces, bunkering station location, pipe routing, engine room arrangement and location of any other spaces containing gas equipment. Location of entrances (air locks as relevant) for spaces with gas equipment are also to be shown.
2	Engine room arrangement	Only if not included in the general arrangement.
3	Design philosophy/description	Including information on the machinery configuration, engine room arrangements, fuel arrangements, shut down philosophy, redundancy considerations etc.
4	Hazardous zones drawing	General arrangement plan with the indication of the hazardous area classification
5	Ventilation system	For gas equipment spaces, including ventilation capacity, location of inlets and outlets, segregation from other ventilation systems.
6	Tank arrangement drawing	Including arrangement of tank connection space and pump rooms/compressor rooms where relevant. The LNG tank design drawings are preferably to contain sufficient detail to allow for structural strength and thermal exposure calculations for surrounding structure.
7	Structural strength calculation for the LNG fuel tank location	
8	Temperature calculations around the LNG fuel tanks	
9	P&ID for LNG bunkering and gas fuel systems	Including details for double piping/ducts and arrangement/ location of vent mast/vent outlet(s) for pressure relief valves and purging.

Item n°	Documentation	Additional description
10	Inert gas system	
11	Structural/passive fire protection in relation to LNG tank/other spaces with gas equipment	
12	Bilge system	Where fitted in spaces containing gas equipment
13	Fire extinguishing in relation LNG tank/other spaces with gas equipment	
14	Stability calculations with LNG tank(s) included	
15	Bunkering station arrangement	Including drip trays, water curtain and any other arrangement needed, in particular when bunkering rate is designed to be high.

**SECTION 25****DOLPHIN QUIET SHIP AND DOLPHIN TRANSIT SHIP****1 General****1.1 Application****1.1.1 (1/3/2017)**

The rules in this Section apply to underwater noise radiation from ships to ensure a low environmental impact.

The additional class notations **DOLPHIN QUIET SHIP** or **DOLPHIN TRANSIT SHIP** are assigned, in accordance with Pt A, Ch 1, Sec 2, [6.14.39] to ships complying with the requirements in this Section.

A Certificate of Compliance may be issued to ships not classed with the Society, fulfilling the requirements of this Section.

**1.2 Terms and Definitions****1.2.1 (1/3/2017)**

For terms and definitions, reference is made to ISO PAS 17208-1 "Quantities and procedures for description and measurement of underwater sound from ships - Part 1: General requirements for measurements in deep water".

**1.2.2 Acoustic Centre (1/3/2017)**

Position at which it is assumed that all of the noise sources are co-located as a single point source.

For the purposes of this section, the position is on a ship.

**1.2.3 Background Noise (1/3/2017)**

Noise from all acoustical and non-acoustical sources when the source under test is not present.

For the purposes of this section, the source under test is a ship.

**1.2.4 Beam Aspect (1/3/2017)**

Direction to either side of the ship under test.

Beam aspect is in reference to the location of the hydrophones.

Another approach for hydrophone measurement (not applied in this section) is bottom aspect, where the hydrophone(s) are mounted at or near the sea floor.

**1.2.5 Closest Point of Approach (CPA) (1/3/2017)**

Point at which the horizontal distance (during a test run) from the acoustic center of ship under test is the closest to the hydrophone(s).

The distance at the closest point of approach is defined by the symbol  $d_{CPA}$ .

**1.2.6 Commence Exercise (COMEX) (1/3/2017)**

Start test range location, position of the ship under test when twice (2x) the "start data" distance ahead of the CPA.

**1.2.7 Data Window Angle (1/3/2017)**

Angle subtended at the hydrophone, between the start data location and the end data location.

**1.2.8 Data Window Length (DWL) (1/3/2017)**

Distance between the start data location and end data location.

The DWL is defined as 1,5x ship length (see [4.1]) and shown in Fig 3.

**1.2.9 Data Window Period (DWP) (1/3/2017)**

Time taken by the ship under test to travel the data window length at a certain speed.

**1.2.10 End Data Location (1/3/2017)**

Position of the acoustic center of the ship under test where data recording is ended.

End data location is one data window length after the start data location. See Fig 3.

**1.2.11 Finish exercise (FINEX) (1/3/2017)**

End test range location, position of the ship under test when twice (2x) the "start data" distance past the CPA.

**1.2.12 Field Calibration (1/3/2017)**

Method of using known inputs, if possible using physical stimuli (such as a known and calibrated/traceable acoustic or vibration source) or electrical input (charge or voltage signal injection) at the input (or other stage) of a measurement system in order to ascertain that the system is responding properly (i.e. within its stated uncertainty) to the known stimulus.

**1.2.13 Frequency Response (1/3/2017)**

Frequency range a system is able to measure, for a given uncertainty and repeatability, from the lowest frequency to the highest stated frequency.

**1.2.14 Geometric far field (1/3/2017)**

Horizontal distance from the ship under test at which the assumption of source co-location causes less than 1 dB of error when adjusting to the reference distance.

**1.2.15 Hydrophone cable drift angle (1/3/2017)**

Angle between the vertical axis and the line created between the fixed support of the hydrophone cable and the hydrophone.

**1.2.16 Insert voltage calibration (1/3/2017)**

Known, calibrated and traceable input stimulus in the form of an electrical input injected at the input (or other stage) of a measurement system in order to ascertain that the system is, in fact, responding properly (i.e. within the system's stated uncertainty and repeatability) to a known stimulus.

**1.2.17 Lloyd's mirror surface image coherence effects (1/3/2017)**

Alteration of radiated-noise levels caused by the presence of a free (pressure release) surface.

Radiation from the "surface image" constructively and destructively influences the source's direct radiation. For the purposes of this section, these effects are considered as part of the source's radiation, causing it to exhibit a vertical directivity.

**1.2.18 Measurement uncertainty (1/3/2017)**

Maximum difference between the measured resulting signature radiated noise level and the true signature radiated noise level stated in decibels for a given measurement system, for one-third-octave bands using a given measurement method (averaging time, bandwidth-time product, etc.).

Reference can be made to ISO/IEC Guide 98-3:2008.

**1.2.19 Measurement repeatability (1/3/2017)**

Expected difference between signature-radiated noise levels resulting from successive measurements on the same ship at the same operating condition, carried out under the same conditions of measurement with the same equipment at the same location, stated in decibels and in one-third-octave bands.

Reference can be made to ISO 3534-1.

**1.2.20 Measurement system (1/3/2017)**

Data acquisition system consisting of, but not limited to, one or more transducer(s), conditioning amplifier(s), analogue-to-digital converter(s), digital signal processing computer and ancillary peripherals.

**1.2.21 Omni-directional hydrophone (1/3/2017)**

Underwater sound pressure transducer that responds equally to sound from all directions.

**1.2.22 Slant range (1/3/2017)**

Distance from the acoustic center of the ship under test to each hydrophone.

**1.2.23 Overall ship length (1/3/2017)**

Longitudinal distance between the forward-most and aft-most perpendicular of a ship.

**1.2.24 Radiated noise level (1/3/2017)**

Measure of the underwater noise radiated by a surface ship, obtained from the root mean square sound pressure level and scaling this quantity according to spherical spreading to a standard reference distance of one meter from the acoustic center of the source.

**1.2.25 Sound speed profile (1/3/2017)**

Measure of the speed of sound in seawater as a function of depth, measured vertically through the water column (only if measurements are carried out in water depth < 100m)

**1.2.26 Start data location (1/3/2017)**

Position of the acoustic center of ship under test where data recording is started.

**1.2.27 Test site (1/3/2017)**

Location at which the underwater noise measurements are performed.

**1.2.28 Sound pressure level (1/3/2017)**

Defined as twenty times the logarithm to the base 10 of the ratio of the root-mean-square pressure of an underwater sound over a stated time interval to the reference value for sound pressure,  $P_{ref}$ , is 1  $\mu$ Pa.

$$L_p = 20 \log_{10} \left( \frac{P_{rms}}{P_{ref}} \right) [\text{dB re } 1 \mu\text{Pa}]$$

**2 Instrumentation, Measurements, Procedures, Reporting****2.1 General****2.1.1 (1/3/2017)**

In order to quantify the underwater sound from a marine ship, three main instrumentation components are required:

- hydrophones and signal conditioning;
- data acquisition, recording, processing, and display system; and
- distance measurement system.

Detailed specifications of each of the measurement systems are given below. A summary of the attributes is given in Tab 1.

**2.2 Hydrophone and signal conditioning****2.2.1 (1/3/2017)**

The term "hydrophone" includes any signal conditioning electronics either within or exterior to the hydrophone. The hydrophone(s) are to have sensitivity, bandwidth, and dynamic range necessary to measure the ship under test and meet the performance noted in Tab 1.

Dolphin Class Notations require three hydrophones which are to be omni-directional across the required frequency range of 10 - 50 000 Hz. However, directional hydrophones may be used, as long as the directional characteristics are accounted for in the final data processing. The hydrophones may or may not have integral cable. However, the required performance is to be obtained with the full cable length to be used during the test.

When portable hydrophones are used, they are to be laboratory calibrated every 12 months according to IEC 60565 (or equivalent standard) for all required one-third octave bands. When fixed (i.e., permanently installed underwater) hydrophones are used, they are to be laboratory calibrated before installation to IEC 60565 (or equivalent standard) for all required one-third octave bands. It is advised to confirm the fixed hydrophone calibration by a comparative measurement utilizing a calibrated underwater sound source or reference hydrophone every 12 months.

The sensitivity and directivity of the hydrophones is to be determined to within  $\pm 1$  dB.

## 2.3 Data acquisition, recording, processing and display

### 2.3.1 (1/3/2017)

The data acquisition, recording, processing, and display system is to be capable of accurately acquiring, recording, processing, and displaying data from the hydrophones. Such systems may comprise tape recorders, computer-based data acquisition systems, or hardware-specific devices (such as spectrum analyzers) or combinations of such. The data acquisition system is to have an appropriate sampling rate and anti-aliasing filters following Nyquist requirements and appropriate dynamic range for either analogue or digital systems. All frequency-domain averaging is to be linear with sampling consistent with the Data Window Period.

The time domain signal from each hydrophone is to be acquired and recorded simultaneously and be sampled accurately for all channels. Tracking and time stamp data are to be recorded synchronously with the acoustic data to enable reconstruction of the track and data processing.

The broadband processing is to cover the one-third-octave bands whose centers are from 10 Hz to 50 000 Hz. Narrow-band processing is to be in appropriate bandwidths relative to the frequencies to be determined up to 5,000 Hz, or higher as needed.

Effective narrowband processing bandwidth is to be reported in the measurement report.

## 2.4 Distance measurement

### 2.4.1 (1/3/2017)

Distance measurement is required to determine continuously the actual distance between the hydrophones and the acoustic center of the ship under test.

For measurement with surface-suspended hydrophones, the distance measurement systems only need to determine the horizontal distance from the sea surface position above the hydrophone(s) (i.e. the device or buoy used to suspend the cable) to the acoustic center of the ship under test. The dis-

tance measurement device may utilize any method (e.g. optical, acoustical, GPS, radar) as long as the required accuracy is achieved. The distance measurement system is to be accurate to 5% of the distance at CPA. The slant range from the ship under test to the hydrophone(s) may be computed during post-processing of the data. It is not necessary to take into account any drift that the hydrophones could experience after they are deployed, provided the hydrophone cable drift does not exceed 5°. If the drift angle does exceed 5°, then it is to either be reduced or the drift angle is to be taken into account when determining the slant range.

For measurement, with bottom-suspended hydrophones, the distance range-finding instrumentation is only to determine the horizontal distance from the sea surface position above the hydrophone(s) (corresponding to the point of attachment of the cable on sea bottom) to the acoustic center of the ship under test. The distance measurement system is to be accurate to 5% of the distance at CPA. The slant range from the ship under test to the hydrophone(s) may be computed during post-processing of the data. It is not necessary to take into account any drift that the hydrophones could experience after they are deployed, provided the hydrophone cable drift does not exceed 5°. If the drift angle does exceed 5°, then it is either to be reduced or the drift angle is to be taken into account when determining the slant range.

The hydrophone cable drift angle may be estimated by the use of depth gages that indicate the difference in depth with hydrophones.

Other means than the cable drift angle can be used to determine accurately the actual distance between the hydrophones and the acoustic center of the ship under test.

## 2.5 Acoustic center

### 2.5.1 (1/3/2017)

It must be possible to control the status of the shell openings from the bridge and/or other location which may be used to continuously monitor security.

**Table 1 : Summary of measurement parameters (1/1/2022)**

Achievable measurement uncertainty (averaged over all one third octave band frequencies)	±2.0 dB
Measurement repeatability	±2.0 dB
Bandwidth	One third octave band
Frequency range, lower one third octave band	10 Hz
Frequency range, upper one third octave band	50 000 Hz (see [2.2])
Narrowband measurements	Optional, up to 5 000Hz
Number of hydrophones	Three
Hydrophone geometry	Figure 1
Nominal hydrophone depth	15°, 30°, 45°
Minimum water depth	Greater of 150m <b>(1)</b>
<b>(1)</b> Measurements in shallow water can be accepted if an adequate procedure for the estimation of the actual transmission loss has been agreed with the Society (e.g. actual measurement of site TL, validated propagation models, etc).	
<b>(2)</b> As an alternative, insert voltage calibration or physical stimuli calibration by pistonphone may be accepted by the Society.	



Minimum distance at closest point of approach (CPA)	Greater of 100m
Distance ranging uncertainty (at CPA)	2%
Acoustic center location	Centerline, see definition
Data Window Length, meters	1.5x ship length (see [4.1])
Data Window Time, seconds	DWL/ship speed
Data window average time	One overall sample or $\leq 1$ second
Minimum number of runs per ship conditions	4 Total, 2 port, 2 starboard
Recommended weather/sea conditions	Sea State Douglass $\leq 3$ ; Wind Speed $\leq 10$ knots
Portable hydrophone calibration	Laboratory calibration every 12 months Field calibration as below daily during measurements for a number of discrete frequencies <b>(2)</b>
Fixed hydrophone calibration	Laboratory calibration prior to installation Confirmation using calibrated sound source or reference hydrophone every 12 months Field calibration as below daily during measurements
System field calibration	Insert voltage calibration
Auxiliary data to be reported	Engine shaft speed, wind speed and direction
<p>(1) Measurements in shallow water can be accepted if an adequate procedure for the estimation of the actual transmission loss has been agreed with the Society (e.g. actual measurement of site TL, validated propagation models, etc).</p> <p>(2) As an alternative, insert voltage calibration or physical stimuli calibration by pistonphone may be accepted by the Society.</p>	

### 3 Measurement requirements and procedure

#### 3.1 Introduction

##### 3.1.1 (1/7/2017)

In order to perform an accurate measurement of a ship's underwater sound, several factors have to be addressed correctly, e.g., selection of an appropriate test site, proper deployment of hydrophones, and proper operation of the ship under test, etc.

#### 3.2 Test site requirements

##### 3.2.1 (1/1/2022)

Dolphin Class Notations do not require the use of a specific ocean location for the measurement test site. It is up to the test organization to determine the suitability of the proposed test site for the intended measurements taking into consideration the specific requirement for water depth of a minimum of 150 m.

Some of the other factors to consider are ambient noise, traffic, oceanography, bottom type, local weather, ship maneuverability and safety.

The background noise is to be low enough to permit measurement of the underwater sound of the ship under test over the frequency range of interest. Where the background noise limits the measurements, corrections are to be applied.

There will be circumstances where the problem of background noise limiting the measurable frequencies is insur-

mountable. In such cases where measured levels are background limited and no correction is possible.

#### 3.3 Sea surface conditions

##### 3.3.1 (1/7/2017)

The sea surface conditions during testing are of concern.

The recommended sea state 3 (Douglass scale) and wind speed limitation of  $\leq 10$  knots (5,4 m/s) provides a nominal value for yachts greater than 100 m.

As a generality, smaller length yachts will require lower wave heights to attain consistent radiated noise level measurements. Smaller yachts may require more benign surface conditions while larger yachts may tolerate larger surface conditions.

#### 3.4 Hydrophone deployment

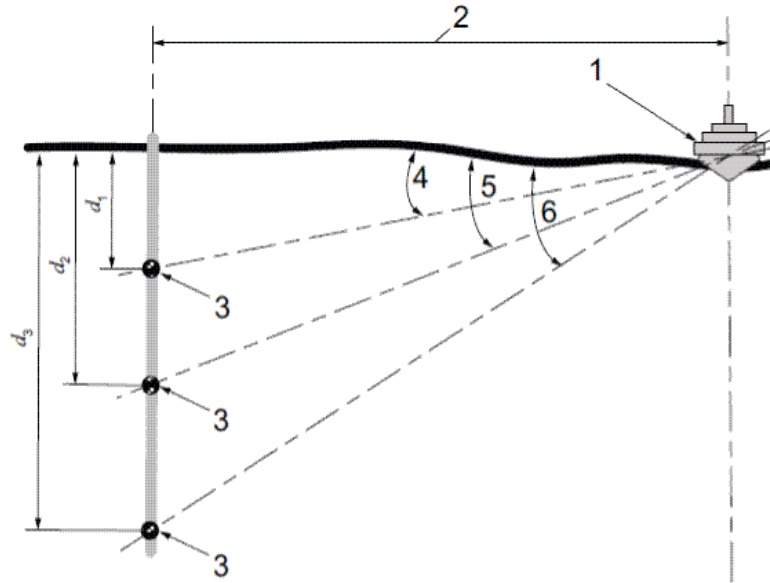
##### 3.4.1 (1/7/2017)

The three hydrophones are to be arranged vertically in the water column. The hydrophones are to be located to measure the beam aspect of the ship under test.

The hydrophones are to be positioned vertically in the water column at depths which result from nominal 15°, 30° and 45° angles from the sea surface at a distance equal to the nominal distance at CPA ( Fig 1).

Provisions are to be taken to mitigate the effects of cable strum and sea surface effects on the measurements. Fig 2 shows potential deployment approaches, but other solutions are allowed as long as the physical locations of Fig 1 and requirements with respect to the measurement uncertainty are fulfilled.

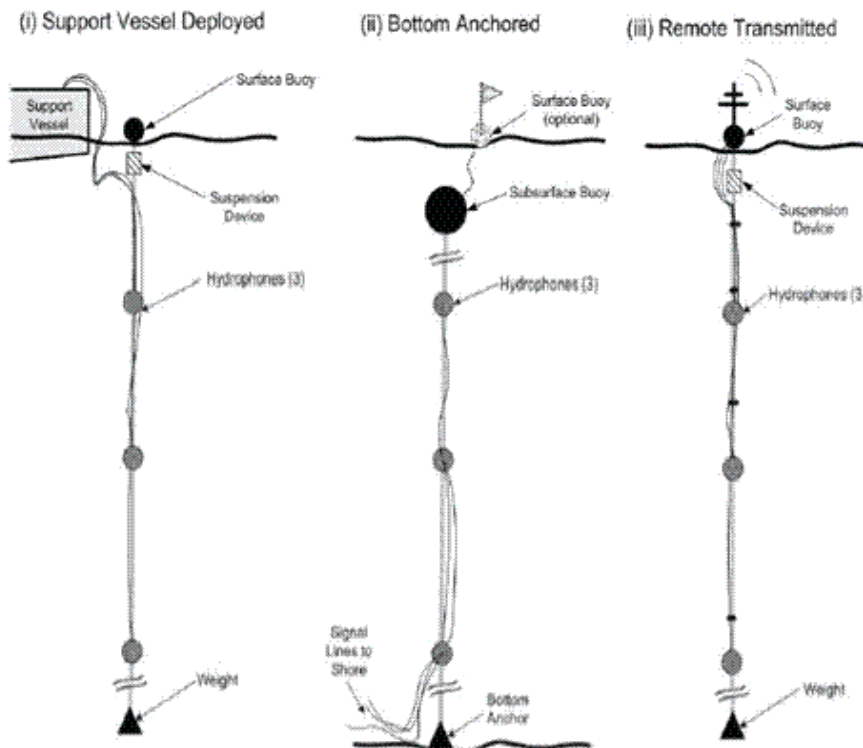
Figure 1 : Hydrophones geometry (1/1/2022)



- 1: ship under test
- 2: distance, dCPA, at closest point of approach
- 3: hydrophone
- 4: 15° angle between surface and shallowest hydrophone
- 5: 30° angle between surface and middle hydrophone
- 6: 45° angle between surface and deepest hydrophone

$d_1 = dCPA \tan(15^\circ)$   
 $d_2 = dCPA \tan(30^\circ)$   
 $d_3 = dCPA \tan(45^\circ)$   
 $dCPA = \text{greater than } 100 \text{ m}$

Figure 2 : Typical hydrophones deployment configurations (not to scale) (1/3/2008)



### 3.5 Test course and ship operation

#### 3.5.1 (1/3/2017)

The run configuration is shown in Fig 3. The ship under test is to transit a straight line course to achieve the required distance at CPA. The starting point of the run (or COMEX) is at least twice the data window length (DWL) before the CPA. The ending point of the run (or FINEX) is twice the DWL after CPA. At COMEX, the ship under test is to have achieved the required run conditions. Unless otherwise required by the run plan, the ship under test is to maintain constant speed, fixed machinery conditions and minimum use of helm to maintain course through FINEX.

### 3.6 Sea Trails

#### 3.6.1 (1/3/2017)

When all aspects of the underwater noise survey are in place the following steps are to be used to conduct each test

run. Four (4) runs with two (2) for each side of the ship (alternating port and starboard aspect) are to be performed for each ship condition to be tested.

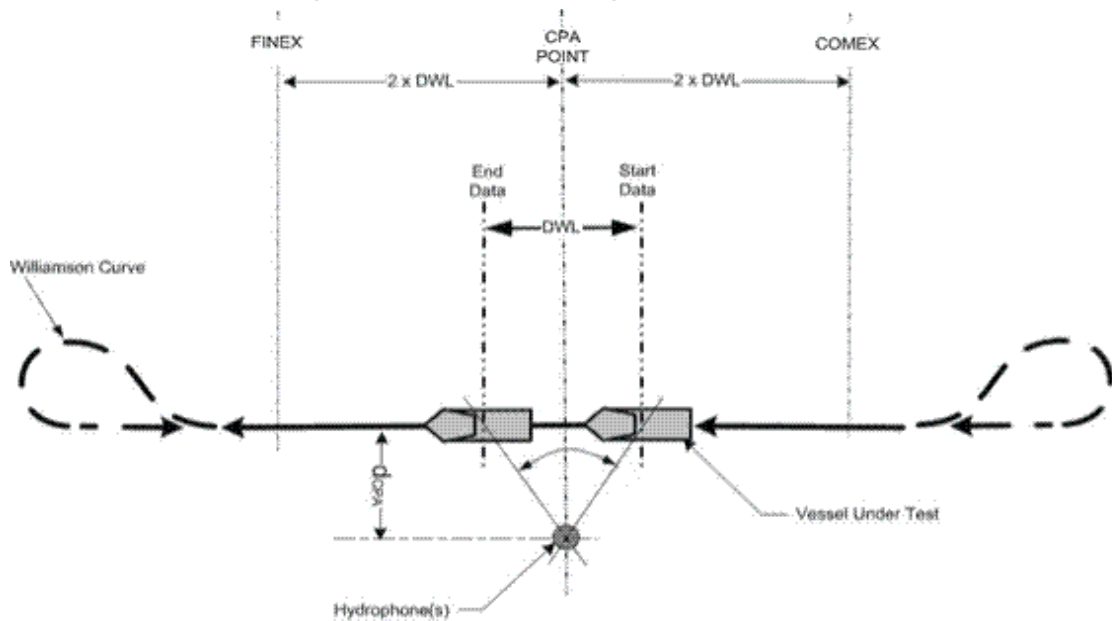
## 4 Post processing

### 4.1 Introduction

#### 4.1.1 (1/3/2017)

When the testing is completed, post processing is required to adjust sound pressure level spectra for background noise and sensitivity, and to normalize the data for distance differences and to combine multiple hydrophones and multiple runs.

Figure 3 : Test course configuration (1/3/2017)



$$d_{CPA} \leq 150 \text{ m}$$

DWL = 1,5 x ship length (0,5x ship length before and 1x ship length after CPA)

$$DWP = DWL / \text{ship speed}$$

As a minimum the DWP is to be one overall sample over which the resulting radiated noise level is to be computed. However, the user may sub-divide the DWP into smaller samples (nominally around 1 second each) to allow for finer evaluation of the acquired data.

### 4.2 Background noise adjustments

#### 4.2.1 (1/3/2017)

A background noise recording have to be carried out before and after the measurement runs.

The signal plus noise to noise ratio, or  $\Delta L$ , is defined in Equation (2).

With the ship stationary, a background measurement (at least 30 s average) is made when the ship is at least 3 km far from the hydrophone(s).

If  $\Delta L$  is greater than 10 dB, then no adjustments are necessary. If  $\Delta L$  is between 3 and 10 dB and if the background noise is sufficiently stationary, then adjustments to the measurements are required using Equation (3). It is to be clearly identified in the report that such corrections have been applied. If  $\Delta L$  is less than 3 dB then the data are to be so noted or discarded.

$$\Delta L = L_{p_{s+n}} - L_{p_n} = 10 \log \left( \frac{P_{s+n}}{P_n} \right) \text{ dB} \quad (2)$$

where:

- $\Delta L$  : is the signal plus noise to noise ratio computed using Equation (2) for each one-third-octave band;
- $p_{s+n}$  : is the root mean square sound pressure at the hydrophone in  $\mu\text{Pa}$ . This value includes both the desired signal and undesired background noise;
- $p_n$  : is the root mean square sound pressure of the background noise at the hydrophone in  $\mu\text{Pa}$ ;

$L_{ps+n}$  : is the sound pressure level in decibels with ship under test present for each run; and

$L_{pn}$  : is the background sound pressure level with the ship under test not influencing the measurement (at 2 km from hydrophones) in dB;

$$L'_p = 10 \log \left( \frac{10^{L_{ps+n}/10}}{10^{L_{pn}/10}} \right) - 10^{L_{pn}/10} \text{ dB} \quad (3)$$

where:

$L'_p$  : is the background noise adjusted sound pressure level of the ship under test, computed in onethird-octave bands.

Equation (3) is only used if  $\Delta L$  is greater than or equal to 3 dB and less than 10 dB.

### 4.3 Sensitivity adjustments

#### 4.3.1 (1/3/2017)

Additional adjustments to the  $L'_p$  value are to be made for any miscellaneous adjustments such as directivity, cable sensitivity, or amplifier gain. Sensitivity adjustments are to be made as given in Equation (4).

$$L_p'' = L_p' + A_{SEN} \quad (4)$$

where:

$L_p''$  : is the unweighted sound pressure level after background adjustment; and

$A_{SEN}$  : is the adjustment for miscellaneous hydrophone sensitivities.

All sensitivity adjustments are made to one-third octave band data. Such adjustments may be measured by the user or provided by the instrumentation vendors.

$L_p''$  is the unweighted sound pressure level.  $L_p'$  is a weighted sound pressure level, where the weighting characterizes the frequency response of the hydrophone and processing chain. This weighting is corrected for by applying a correction  $A_{SEN}$  in each one-third octave bands.

### 4.4 Distance normalization

#### 4.4.1 (1/3/2017)

The final adjustment of the sensitivity-adjusted measured sound pressure level,  $L_p''$ , is normalization for distance. The typical distance from the moving ship to the measurement transducer is 150 m. However, because of the effects of current and seas this distance may vary by  $\pm 10\%$ , which is acceptable as long as the distance from the hydrophones to the acoustic centre of the ship is known.

Depending on measurement technology used (e.g., GPS, Sonar, or Laser), the distance from the ship to the hydrophone may need to be computed using two separate distances:

- horizontally from the ship's acoustic centre to the sea surface above the hydrophone(s); and
- vertically from the sea surface to each hydrophone. The total distance from the ship to each hydrophone is determined using Equation (5).

$$d_{Total} = \sqrt{d_{horz}^2 + d_{vert}^2} \quad (5)$$

where:

$d_{Total}$  : is the total distance to be used in the distance normalization Equation (6) below;

$d_{horz}$  : is the horizontal distance from the acoustic centre of the ship under test to the surface buoy supporting the hydrophone(s). This distance would be that determined by the distance ranging system (i.e., GPS System, Sonar, or Laser Range Finder). The following corrections to the measured ranging value may be needed: to the centreline, to the waterline, and to the acoustic centre; and

$d_{vert}$  : is the depth of each hydrophone (h, where h1 for shallow hydrophone, h2 for middle hydrophone, and h3 for deep hydrophone).

The underwater sound radiated noise level for each run and each hydrophone is determined by Equation (6).

$$L_s(r, h) = L_p'' + 20 \log(d_{Total}/d_{ref}) \text{ dB} \quad (6)$$

where:

$L_s(r, h)$  : is the underwater sound radiated noise level at a reference distance of 1 m, as a function of run number (r) and hydrophone location (h, where h1 for shallow hydrophone, h2 for middle hydrophone, and h3 for deep hydrophone);

$d_{Total}$  : is the total distance from the ship under test to each hydrophone (meters); and

$d_{ref}$  : is the reference distance of 1 m.

This normalization assumes that the ship is a directive source at the surface (i.e., the surface image is considered as part of the source and the underwater sound pressure level is specific for the beam aspect at elevation angles between  $15^\circ$  and  $45^\circ$ ).

### 4.5 Hydrophone and run combination post processing

#### 4.5.1 (1/3/2017)

The resulting data set from measurements performed is to be one-third-octave-band sound radiated noise levels relative to  $1 \mu\text{Pa}$  m in decibels from 10 to 50 000 Hz. Such data sets are to be prepared for three hydrophones and for four measurement runs, two per aspect (port or starboard). The port and starboard aspect runs are to be kept separate. These multiple data sets are to be adjusted and normalized according to [4.2] through [4.4], above. This paragraph [4.5] describes how to combine the twelve data sets for each condition into one set of values in one-third-octave bands.

The first step in the post-processing is to determine the power average of the sound radiated noise level from all three hydrophones (h1, h2, and h3) which results in the sound radiated noise level for each run,  $LS(r)$  using Equation (7).

$$L_s(r) = 10 \log \left\{ \left( 10^{L_s(r, h1)/10} + 10^{L_s(r, h2)/10} + 10^{L_s(r, h3)/10} \right) / 3 \right\} \text{ dB} \quad (7)$$

where:

- $L_s(r)$  : is the power-averaged underwater sound radiated noise level at the reference distance of 1 m for three hydrophones for run number r.
- $L_s(r,h1)$  : is the underwater sound radiated noise level for the shallow (h1) hydrophone for run number r.
- $L_s(r,h2)$  : is the underwater sound radiated noise level for the middle (h2) hydrophone for run number r.
- $L_s(r,h3)$  : is the underwater sound radiated noise level for the deep (h3) hydrophone for run number r.

The four runs of data are then arithmetically averaged to determine the final sound source value for each run as given in Equation (8).

$$L_s = \frac{\sum_{r=1}^{r=k} L_s(r)}{k} \quad (8)$$

where:

- $L_s$  : is the radiated noise level for k runs as computed in Equation (8).
- $L_s(r)$  : is the power-averaged underwater sound radiated noise level at the reference distance of 1 m for three hydrophones for run number r, as determined by Equation (7).
- k : is the total number of runs: for k = 4 or 2 (for port- and starboard-only computations).

For each ship condition,  $L_s$  is to be determined separately for each side of the ship (i.e., port aspect and starboard aspect) and then for both sides together.  $L_s$  is the resulting radiated noise level for each ship operating condition. It is a function of one-third octave bands and is to be the values that are reported, compared to limits or compared to other data sets.

## 5 Reporting Example

### 5.1

#### 5.1.1 (1/3/2017)

The test report is to include all the information and data required to verify the fulfillment of the notation.

The minimum set of information is to be agreed with the Society before carrying out the trials.

## 6 Assignment criteria

### 6.1

#### 6.1.1 (1/3/2017)

The additional class notation **DOLPHIN QUIET SHIP** is assigned to ships complying with limits given in Fig 4 at 10knt.

The additional class notation **DOLPHIN TRANSIT SHIP** is assigned to ships complying with limits given in Fig 4 at contractual normal sea going conditions.

The Society will assess the reported results, documented operating conditions and any other relevant information. If the results are found to be acceptable the relevant underwater noise class will be issued.

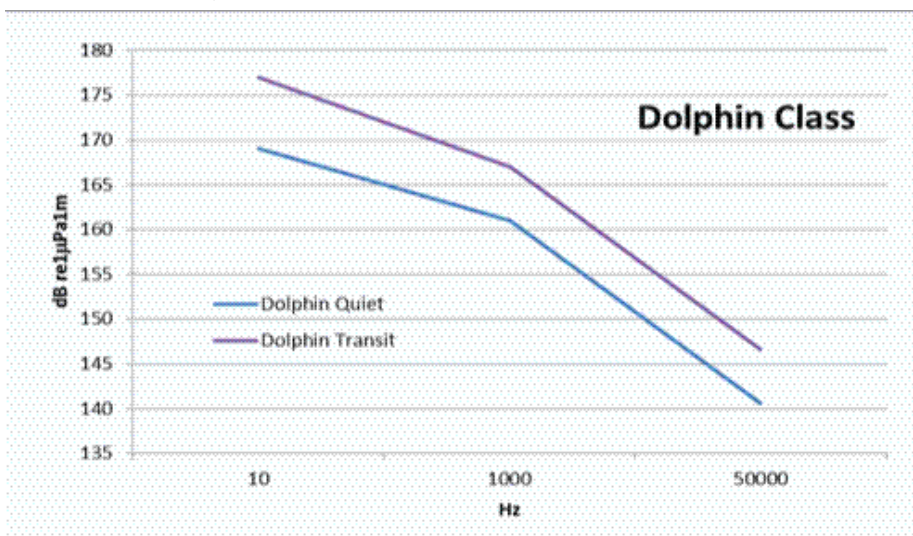
## 7 Equivalence

### 7.1

#### 7.1.1 (1/3/2017)

If some measurement requirement cannot be fulfilled, the Society may accept an exception as far as it is well motivated, technically documented and do not impact on the final result.

**Figure 4 : Limits for DOLPHIN QUIET SHIP and DOLPHIN TRANSIT SHIP Additional Class Notations (1/3/2017)**



**DOLPHIN QUIET SHIP Notation:**

10Hz - 1000Hz: 173-4\*LOG10(f)

1kHz - 50kHz:161-12\*LOG10(f/1000)

**DOLPHIN TRANSIT SHIP Notation:**

10Hz - 1000Hz: 182-5\*LOG10(f)

1kHz - 50kHz:167-12\*LOG10(f/1000)

**SECTION 26****EXHAUST GAS CLEANING SYSTEMS  
(EGCS-SOX AND EGCS-NOX)****1 General****1.1 Application****1.1.1 (1/7/2017)**

The additional class notation **EGCS-SOx** assigned, in accordance with Pt A, Ch 1, Sec 2, [6.14.41], to ships onto which an Exhaust gas cleaning system suitable to reduce the SOx emissions is installed and certified by the Society according to the requirements of this section.

The additional class notation **EGCS-NOx** assigned, in accordance with Pt A, Ch 1, Sec 2, [6.14.41], to ships onto which an Exhaust gas cleaning system suitable to reduce the NOx emissions is installed and certified by the Society according to the requirements of this section.

**1.2 Basic principles****1.2.1 (1/4/2021)**

The installed equipment is to be certified as complying with the performance standard established by international Regulations and Guidelines, and tested by the Society according to the Rules applicable to equipment intended for essential services, both when installed on new ship or retrofitted to existing ships.

Special consideration will be given to the assignment of the additional class notations to existing ships entering into Tasneef Class as existing ships not built under Society surveillance, previously fitted with properly certified equipment.

**2 Definitions and acronym****2.1****2.1.1 (1/7/2017)**

EGCS: Exhaust gas cleaning system

Nox: Nitrogen oxides

SOx: sulphur oxides

EIAPP: Engine International Air Pollution Prevention Certificate (NOx)

ETM: Exhaust Gas cleaning system (SOx) Technical Manual

OMM: On-board monitoring manual (SOx)

SECP: Ship Emission compliance plan (SOx)

SCR: Selective catalytic reduction

**3 Documentation to be submitted****3.1****3.1.1 (1/7/2017)**

Before the survey for the assignment of the notation is carried out, the following documentation is to be submitted for information:

- a) EIAPP Certificates relevant to the engines fitted Selective Catalytic Reduction systems;
- b) NOx Technical files of engines fitted Selective Catalytic Reduction system;
- c) Testing certificates of each engine fitted with an EGCS for NOx, or of the Selective Catalytic Reduction system, if separately certified;
- d) ETM of installed Exhaust Gas cleaning systems for SOx, in approved form;
- e) OMM of installed Exhaust Gas cleaning systems for SOx, in approved form;
- f) SECP in approved form
- g) Testing certificates of each EGCS system (SOx) fitted on board.

The Society reserves the right to request the submission of additional documents, if deemed necessary, for the evaluation of compliance of the installed system.

**4 Requirements****4.1 General****4.1.1 Performance and certification (1/7/2023)**

The installed equipment is to be certified as complying with the performance standard established by international Regulations and Guidelines, in particular:

- a) EGCS for reducing NOx emission are to be certified according to Resolutions MEPC.176(58)(MARPOL Annex VI), MEPC.177(58) (NOx Technical Code 2008) and MEPC.291(71) as capable of achieving NOx emission levels conforming to Tier 3 standard.
- b) EGCS for reducing SOx emission are to be certified according to Resolution MEPC.340(77). The achieved SO<sub>2</sub>/CO<sub>2</sub> ratio, when the connected fuel oil burning equipment is operated at any rating and supplied with fuel with 3.5 % sulphur content (equivalent to using a fuel with sulphur content as specified in Resolution MEPC.340(77)), is to be verified. The equivalent value of fuel sulphur content, in percentage, is to be indicated in brackets (e.g. EGCS-SOX(0,5%) or ECGS-SOX(0,1%)).

All the above mentioned Resolutions are to be applied in the "as amended, repealed or replaced status" in force or

applicable at the date of the request of issuance of the additional notation, or at the date of the contract for the supply and installation on board of the equipment, if earlier.

The equipment is to be tested by the Society according to the Rules applicable to equipment intended for essential services, both when installed on new ships or retrofitted to existing ships.

#### **4.1.2 Inspection and maintenance (1/7/2017)**

Maintenance of the system is to be carried out regularly in accordance with the maker's instructions and internal procedures.

The plan is to describe the list of points to be inspected and the people in charge.

The reports of maintenance activities and inspections are to be maintained for at least three years, and are to be made available, upon Surveyor request, during the survey for the assignment of the notation and subsequent surveys.

#### **4.1.3 Monitoring and recording (1/7/2017)**

The monitoring and recording of the proper operation of the EGCS is to be carried out according to the requirements of the Resolutions quoted in [1.2.1].

The plan is to describe the list of points to be inspected and the people in charge.

Additionally, in case of SCR systems not permanently fitted with a NOx analyser for closed loop control, a periodical NOx measurement is to be carried out by qualified personnel, at intervals not exceeding five years, to check the efficiency of the system and confirm compliance with the requirements in [1.2.1].

## **5 Assignment criteria**

### **5.1 General**

#### **5.1.1 Performance and certification (1/7/2017)**

The additional class notation **EGCS-NOX** is assigned to ships or new buildings upon verification of compliance of the documentation required in [3.1.1] a), b) and c) with the requirements in [4.1.1].

The additional class notation **EGCS-SOX** is assigned to ships or new buildings upon verification of compliance of the documentation required in [3.1.1] d), e), f) and g) with the requirements in [4.1.1].

**SECTION 27****MAN OVERBOARD DETECTION SYSTEM (MOB)****1 General****1.1 Application****1.1.1 (1/11/2018)**

The additional class notation **MOB** is assigned, in accordance with Pt A, Ch 1, Sec 2, [6.14.43], to passenger ships equipped with a Man Overboard Detection Systems (MOB detection systems) fulfilling the requirements of this section.

Applicability to cargo ships may be considered on a case by case basis at the discretion of the Society.

A Certificate of Compliance may be issued to ships not classed with the Society, fulfilling the requirements of this section.

For ships classed with the Society, the Owner or management Company can choose to request the assignment of the additional class notation or the issue of Certificate of Compliance.

**1.2 Reference Rules and Standards****1.2.1 (1/11/2018)**

- ISO/PAS 21195 Systems for the detection of persons while going overboard from ships (Man overboard detection)
- Cruise Vessel Security and Safety Act of 2010, as implemented with 46 CFR Part 70-6 (applicable to passenger vessel not engaged in coastal voyage, which embarks or disembarks passengers in the United States and fitted with sleeping facilities for at least 250 passengers).

**2 Definitions****2.1****2.1.1 (1/11/2018)**

- Man overboard (MOB) detection system: system installed on board designed to detect persons who have gone overboard from a ship.
- Man overboard (MOB) event: incidents in which a person has accidentally or intentionally gone over the side/front/back of a ship and into the water.
- False alarm: system activation not caused by an actual MOB event.
- MOB data: information captured and/or generated by the MOB detection system.
- Control station: equipment that provides the facilities for human observation and control of the MOB detection system.
- Sensor unit: device or system of devices that detects and responds to one or more physical stimuli.

**3 Documentation to be submitted****3.1 Technical documentation****3.1.1 (1/11/2018)**

The documents listed in Tab 1 describing the system functioning and management are to be submitted to the Society.

**3.2 Company procedures****3.2.1 (1/11/2018)**

When installing a Man Overboard Detection System, at least the procedures listed in Tab 2 are to be revised or developed and submitted to the Society.

**Table 1 : Technical documents to be submitted (1/11/2018)**

No.	I/A (1)	Documents
1	A	Test plan (2)
2	I	MOB detection system testing according to ISO/PAS 21195 or Maker's declaration
3	I	MOB detection system description including flow chart of operations
4	I	Deck plans with sensor units layout
5	I	System drawings and technical manuals
6	I	Training manual for personnel in charge of MOB detection system
7	I	Procedures for system maintenance
<p>(1) A: to be submitted for approval I: to be submitted for information</p> <p>(2) Final test plan is approved during the initial survey kick off meeting. Please refer to [6.5]</p>		



No.	I/A (1)	Documents
8	I	Operating manuals including procedures for system malfunctioning, failures and alarms management
9	I	Control station layout
<p>(1) A: to be submitted for approval I: to be submitted for information</p> <p>(2) Final test plan is approved during the initial survey kick off meeting. Please refer to [6.5]</p>		

**Table 2 : Company procedures to be submitted (1/11/2018)**

No.	I/A (1)	Documents
1	A	SMS Manual (ISM Code Reg.7)
2	I	Master's decision support system (SOLAS reg. III/29 according to IMO Res. A.1072(28))
3	I	Incident response plan (according to IMO Res. A.1072(28))
4	I	IAMSAR Manual (SOLAS reg. V/7 according to IMO Res. A.894(21))
5	I	Procedure for alternative MOB detection in case of system out of service or invasive works interfering with MOB detection system
6	I	Any other relevant Company procedure affected by the installation of the MOB detection system
<p>(1) A: to be submitted for approval I: to be submitted for information</p>		

## 4 Design and requirements

### 4.1 General requirements

#### 4.1.1 (1/11/2018)

MOB detection system consists of a control station, sensor units, cables and associated software. Sensor units are to be accessible for maintenance and settings.

These requirements do not cover MOB detection systems requiring to the passengers or crew to wear or carry a device to trigger a MOB event or necessitating a human interaction to trigger a MOB warning.

The system is to be capable of withstanding typical environmental conditions that may be encountered on the ship.

The MOB detection system is to be either certified according to ISO/PAS 21195, or declared by the system Maker to be in compliance with equivalent standards.

In case a type approval certification of the hardware is voluntary required by the Maker, reference is to be made to Pt C, Ch 3, Sec 6.

### 4.2 MOB detection zone

#### 4.2.1 (1/11/2018)

The system is to be capable of detecting persons that pass through the MOB detection zone while going overboard.

The MOB detection zone is to be designed to cover the entire periphery of the ship and is to be extended outside of the ship up to a minimum of 5 m from the periphery of the ship including the overhanging lifeboats.

Limited areas not covered by sensor units (e.g. due to particular shapes of the ship, like recesses) are allowed pro-

vided that proper means are in place to avoid the access to passengers and crew members.

### 4.3 MOB event alarms and data

#### 4.3.1 (1/11/2018)

The system is to be designed to capture an image of a falling person and to generate an immediate visual and audible alarm in a manned station in response to a MOB event warning.

MOB data are to be available to a manned position within five seconds of a MOB event warning.

A MOB alarm log is to be generated when a MOB event warning is initiated and relevant details about time, date, address of the sensor units that initiated the MOB alarm, ship position and speed are to be contained in the alarm log. Time code input is to be from a valid coordinated universal time (UTC) feed.

A NMEA (National Marine Electronic Association) message is to be generated once a MOB event is confirmed and be in compliance with the requirements in [4.7] and [4.8].

In test mode, any MOB event is to be clearly identified by the system.

### 4.4 System log

#### 4.4.1 (1/11/2018)

Data are to be stored in a resilient and redundant device for a minimum of 30 days in normal condition and for at least 120 days in case of MOB event.

Video records are to be kept in a secure location to prevent unauthorized access or tampering.

Each action on the system (at least: logons, logoffs, data export, software modifications, and system setting changes)

is to be recorded in a security log including all necessary information.

#### 4.5 Control, monitoring and safety

##### 4.5.1 (1/11/2018)

The system is to be self-monitoring type in respect of internal failures.

The system status is to be continuously monitored and any malfunctioning is to be immediately detected and managed with proper procedures.

In the event of failure, an alarm is to be activated.

Failure of the power supply is to generate an alarm.

The system is to be powered by the transitional source of emergency electrical power or by an equivalent emergency source.

#### 4.6 Control station

##### 4.6.1 (1/11/2018)

Access to control station is to be restricted to users with appropriate credentials to be established by the ship Owner or the ship management Company.

#### 4.7 Event markers

##### 4.7.1 (1/11/2018)

The NMEA message as requested in [4.3] is to be compatible with the integrated bridge system (IBS) and the Electronic chart display and information system (ECDIS). Any connection to the IBS or ECDIS is to be such that the IBS or ECDIS suffers no deterioration, even in case of any failure in the MOB detection system.

MOB event messages are to be compliant with NMEA 0183 or NMEA 2000® communication protocol.

The MOB event messages are to be relayed to the IBS or ECDIS provided that the requirements for these systems are not compromised.

Note 1: IEC 61162 series provides additional information on the application of NMEA 2000® aboard SOLAS ships.

#### 4.8 Voyage Data Recorder

##### 4.8.1 (1/11/2018)

The MOB detection system is to be fitted with an interface compatible with the voyage data recorder (VDR). Any connection to the VDR is to be such that the VDR suffers no deterioration, even if the MOB detection system develops faults.

The MOB alarm log is to be recorded in a format that complies with the international digital interface standards set forth in IEC 61162 series using approved sentence formats.

The MOB alarm log is to be recorded on the VDR provided that the requirements for the recording and storage of the mandatory data are not compromised.

## 5 Personnel in charge of MOB

### 5.1 Qualification of personnel in charge of MOB

#### 5.1.1 (1/11/2018)

Persons in charge for the MOB detection system are to be qualified.

Training manual for personnel in charge of MOB detection system is to be submitted for review.

Relevant manuals for the use of the system, including the management of any system fault or alarm are to be included in the training documentation.

### 5.2 Company procedure

#### 5.2.1 (1/11/2018)

Company procedures have to include duties and shifts of personnel in charge of MOB detection system and checklists to be filled after any key event (system logon and logoff, false alarm, MOB event).

## 6 Initial survey

### 6.1 Testing devices

#### 6.1.1 (1/11/2018)

The system is to be evaluated using a manikin with at least the following features:

- Height of 1.467 m ± 25%
- Human shape with two arms, two legs, a torso and a head
- Possibility to warm up it in case of sensor unit based on thermal cameras.

### 6.2 Environmental conditions

#### 6.2.1 (1/11/2018)

The system is to be tested in an identified environmental conditions including at least:

- Tests during navigation
- Tests during daylight
- Tests during the night
- Test with different backlight and front light conditions
- Ship speed in a range between 0 knots and the maximum design speed.

### 6.3 Information to be collected about the system

#### 6.3.1 (1/11/2018)

All the details about MOB detection system are to be included in system test report.

Main data about the system are to be at least the following:

- Ship's name (RI or IMO number)
- Manufacturer
- ISO/PAS 21195 certification details or Maker's declaration (see 4.1)
- Sensor unit type
- Sensor unit identification number and location
- Software release.

#### 6.4 Information to be collected about the dropping test with manikin

##### 6.4.1 (1/11/2018)

Main data about dropping test with the manikin are to be at least the following:

- Date and time of test
- Identity of the sensor unit that initiated the MOB alarm
- Ship location
- Ship heading
- Ship speed
- Environmental conditions.

#### 6.5 Initial survey procedure

##### 6.5.1 (1/11/2018)

Prior to starting the initial survey, a kick-off meeting between the Society and the ship Owner or ship management Company is to be made to review and agree the final testing plan based on the review of tests performed according to ISO/PAS 21195 or Maker's declaration.

The initial survey includes the execution of a test as per the approved testing plan.

At least the following verifications are to be carried out:

- At least 40 manikin droppings are to be carried out during navigation
- At least 30% of the droppings are to be carried out during the night
- Tests during daylight are to be carried out with different backlight and front light conditions (front/back/side)
- The whole ship envelope (forward and aft area, port and starboard side) is to be covered by manikin droppings
- Particular ship's areas like forward area and recesses, are to be carefully tested as a priority
- Visual and audible alarms are to be checked
- The behavior of system in case of power failure is to be checked
- Access to system through the control station is to be verified
- Operational procedures for system management, including sensor unit offline and activities carried out in MOB detection zone and interfering with system functioning, are to be checked
- System log is to be checked in order to verify that each event is recorded and detailed as required
- All the requirements listed in [4] are to be verified.

#### 6.6 Probability of detection and false alarm

##### 6.6.1 (1/11/2018)

The probability of detection of a MOB manikin is to be greater or equal to 95 % in the environmental conditions set out in the test plan. This means that only two of the 40 manikin droppings can fail.

In case of detection failure, relevant report section is to be filled and failure cause to be investigated.

False alarms are to be measured over a period of 30 days and averaged over that period. The average is not to be more than one false alarm per day. False alarms per day are to be no more than four.

In case of false alarm during testing campaign, the following information is to be recorded in a dedicated report:

- Date and time
- Activated sensor unit details
- False alarm reason
- Environmental condition
- Ship's details.

### 7 Test report

#### 7.1

##### 7.1.1 (1/11/2018)

At the end of every test campaign, a test report is to be delivered containing at least the following technical information:

- System description
- Kick off meeting minute and test plan
- Testing devices used for testing
- MOB detection system test report
- MOB dropping test report
- False alarms report.

### 8 Certificate

#### 8.1

##### 8.1.1 (1/11/2018)

In case a certificate is required by the Owner or management Company, the certificate is valid for a period of 5 years subject to annual confirmation and renewal at the end of the validity period.

## SECTION 28

## HYBRID PROPULSION SHIP (HYB-...)

### 1 General

#### 1.1 Application

##### 1.1.1 (1/1/2019)

The additional class notation **HYBRID PROPULSION SHIP (HYB-...)** is assigned to ships equipped with a hybrid propulsion system complying with the requirements of this Section.

##### 1.1.2 (1/7/2023)

The requirements of this section are additional to those applicable in other parts of the Rules; in particular:

- where batteries other than Lead and Nickel-Cadmium batteries are provided as energy storage, the requirements in Pt C, Ch 2, App 2 "BATTERY POWERED SHIPS" apply;
- where fuel cells are provided as energy generation sources, the requirements in Pt C, Ch 2, App 3 "FUEL CELL POWERED SHIPS" apply.

#### 1.2 Definitions

##### 1.2.1 (1/7/2023)

- Hybrid propulsion system: a propulsion system having two or more different sources of power such as mechanically transmitted power from internal combustion engines, electrical power or hydraulic power so arranged that the ship may be propelled by using the different power sources both separately and in combination (in case the system only allows the separate use, the notation "AVM-APS" will be considered).
- Power management system (PMS): a system that ensures continuity of electrical supply under all operational conditions.
- Primary power distribution system: a system supplied directly by the sources of power.
- Redundancy: the ability of a component or system to maintain or restore its function, when a single failure has occurred. Redundancy can be achieved, for instance, by installation of multiple components, systems, network or alternative means of performing a function.
- Failure mode and effects analysis (FMEA): systematic analysis of systems and sub-system to identify all potential failure modes down to the appropriate sub-system level and their consequence.

### 1.3 Additional Class Notation

#### 1.3.1 (1/7/2023)

The notation **HYB-...** is to be completed by additional symbols according to the type of hybrid system:

- **E x/y** : ship having an hybrid propulsion system driven by combustion engine(s) and electric motor(s)
- **H x/y** : ship having an hybrid propulsion system driven by combustion engine(s) and hydraulic motor(s)

Where x represents the total classification power in MW of the combustion propulsion engine(s) and y represents the total rated power in MW of the electric or hydraulic propulsion motor(s).

Other symbols may be used to identify specific types of hybrid propulsion other than the above.

## 2 Documentation to be submitted

### 2.1 General

#### 2.1.1 (1/7/2023)

In addition to the documents required by Pt C, Ch 2, Sec 1, [2] and Pt C, Ch 3, Sec 1, [2], the following documents are to be submitted for approval:

- a) a general description of the arrangement of the entire hybrid system, including control and protection system;
- b) a general specification and a diagram of control, alarm and safety systems, including the list of the components installed;
- c) a FMEA, according to Tasneef "Guide for Failure mode and Effect Analysis" or other equivalent methods, of the entire hybrid system, including power supplies, auxiliaries, control and protection system, to demonstrate the availability of ship propulsion and main source of power in case of failure of one power source in all operating mode;
- d) a Test Program identifying the tests to be carried out in order to verify the assumptions and conclusions of the FMEA of item d);
- e) power balance of main source of power at the different operating mode;
- f) performance specification (power curve) of the prime mover over the selected speed range, where variable speed generators are provided.

### 3 Functional requirements

#### 3.1 Application

##### 3.1.1 (1/1/2019)

The hybrid propulsion system comprises the following systems:

- energy generation sources (such as fixed or variable speed generators, fuel cells, hydraulic power units);
- power distribution system;
- propulsion system;
- control system.

#### 3.2 Hybrid electric propulsion

##### 3.2.1 Power distribution system (1/7/2023)

For systems assigned with the **HYB-E** notation, the primary electrical power distribution system can be AC or DC as follows:

- DC switchboard: a primary DC distribution system connected to AC systems by means of inverter units, feeding power in both directions; DC power sources, such as fuel cells or batteries, may be connected to the DC distribution system through a controlled DC/DC converter or directly,
- AC switchboard: a primary AC distribution systems either at fixed frequency and voltage or variable frequency.

The AC and DC distribution systems are to comply with Pt C, Ch 2, Sec 3, [1.1].

Distribution system, having fixed frequency and voltage, are to comply with the requirements of Pt C, Ch 2, Sec 2, [2].

Alternatively, where the characteristics of the power supply is outside the limits specified in Pt C, Ch 2, Sec 2, [2] (e.g. due to the batteries voltage drop), it is to be demonstrated to the Society that all the circuits connected to the network operate satisfactorily under the normally occurring variation in voltage and frequency.

Load sharing between the different energy sources is to be performed by a power management system (PMS); the PMS is to take into consideration that the available power, for each power source, may be a constant or a variable value depending on the speed, state of charge or other characteristics of the energy sources.

For variable speed generators, allowing for a wide speed range of the prime mover, the configuration of the power management system (PMS) is to take into account the variation in available power at the different prime mover speeds within the operating range.

##### 3.2.2 Electrical Protection (1/1/2019)

Each inverter is to be equipped with a built-in protection to control any external faults. For fault in the inverter itself, a separate protection is to be installed (e.g. fuses).

Where combinations of AC and DC distribution systems are used:

- they are to be coordinated in such a way that safe operation is possible for all normal and single fault

conditions: parallel operation of such systems is to be documented and verified by tests;

- full downstream selectivity is to be provided in all operating modes.

##### 3.2.3 Protection of fixed and variable speed AC generator (1/1/2019)

Electrical protection of generators is to comply with requirements of Pt C, Ch 2, Sec 3, [7.8], as far as applicable.

The reverse-power protection for variable speed AC generators may be omitted if it is demonstrated that the rectifier is capable to block any back feeding of power.

Variable speed AC generators are to be fitted with fault protection systems (e.g. circuit breakers) that are suitable over the entire speed range (both thermal conditions and short circuit fault currents as well as voltage regulation are to be considered).

Where a permanent magnet excited generator is provided or when field winding cannot be de-excited, a separate protection is to be provided in order to stop the prime mover in case of short circuit between the inverter/breaker and the generator.

For generators designed to operate in parallel at any speed within a selected speed range, the power and fault current capabilities for this speed range are to be documented.

#### 3.3 Hybrid hydraulic propulsion

##### 3.3.1 (1/7/2023)

For systems assigned with the **HYB-H** notation, the requirements in Pt C, Ch 1, Sec 10, [14] apply.

### 4 Testing

#### 4.1 Tests on board

##### 4.1.1 (1/7/2023)

After installation and after any important repair or alteration which may affect the safety of the arrangement, following a check of compliance with the plans, the entire hybrid system is to be subjected at least to the following tests and inspections, in addition to the tests required by Pt C, Ch 2, Sec 15:

- functional test of the hybrid system in the different configurations;
- verification of active load sharing between different power sources;
- verification of reactive load sharing between different power sources;
- sudden load disconnection and load ramp-up to verify battery system capability;
- test of max charging capabilities of batteries;
- test of start and stop of engines;
- test of system stability during faults (including test for FMEA trials);
- testing of pre-charge system in inverters when re-connected;
- proper working of alarms;
- quality of power in different operational modes.

## SECTION 29

## CYBER RESILIENCE

### 1 General

#### 1.1 Application

##### 1.1.1 (1/1/2019)

The additional class notations **CYR (Cyber resilience)**, **CYR-OT (Cyber resilience of Operational Technology)** or **CYR-IT (Cyber resilience of Information Technology)** are assigned, in accordance to Pt A, Ch 1, Sec 2, [6.14.45], to ships complying with the requirements in this section.

##### 1.1.2 (1/1/2019)

A Certificate of Compliance may be issued to ships not classed with the Society, fulfilling the requirements of this section.

#### 1.2 Assignment criteria

##### 1.2.1 (1/1/2019)

These class notations may be assigned to ships in service and new ships.

##### 1.2.2 (1/1/2019)

The additional class notation **CYR-OT** is assigned when the requirements in this section are applied to computer based systems (CBS) subject to the requirements in Pt C, Ch 3, Sec 3 (OT Systems).

##### 1.2.3 (1/1/2021)

The additional class notation **CYR-IT** is assigned when the requirements in this section are applied to CBS not subject to the requirements in Pt C, Ch 3, Sec 3 (IT Systems), but having hardware adequate to be used in marine environment and equipped with firmware, operating systems and software designed and implemented according to software quality standards, such as ISO 9001 associated with ISO 90003, or equivalent.

##### 1.2.4 (1/1/2019)

The additional class notation **CYR** is assigned to ships for which both class notations **CYR-IT** and **CYR-OT** are assigned.

##### 1.2.5 (1/1/2021)

For the assignment of either **CYR-OT** or **CYR-IT**, or both (**CYR**), systems, equipment and components used in CBS onboard shall provide evidence of suitable capabilities of cyber resilience, e.g. by means of certification of compliance to international standards such as ISA/IEC 62443 family of standards, as applicable, or equivalent.

#### 1.3 Maintenance, suspension and withdrawal of the notation

##### 1.3.1 (1/1/2019)

The maintenance of the **CYR**, **CYR-IT** and **CYR-OT** notations is subject to the same principles as those for the maintenance of class: annual and renewal surveys are to be carried out by their limit dates and possible recommenda-

tions (related to the notation) are to be dealt with by their limit dates.

##### 1.3.2 (1/1/2019)

The annual and renewal surveys are to include:

- verification of availability onboard of up-to date documentation described in Tab 1 or up-to date Cyber Resilience Manual;
- verification of implementation of the safeguards and measures described in the above mentioned documentation or Manual;
- execution of sample tests to the surveyor's satisfaction.

##### 1.3.3 (1/1/2019)

Failures found in performing the tests or deficiencies in the documentation may lead either to imposition of recommendations or to suspension of the notations.

##### 1.3.4 (1/1/2019)

The suspension of class automatically causes the suspension of the **CYR**, **CYR-IT** and **CYR-OT** notations.

##### 1.3.5 (1/1/2019)

The withdrawal of the **CYR**, **CYR-IT** or **CYR-OT** notations may be decided in the following cases:

- Recurrent suspension of the **CYR**, **CYR-IT** or **CYR-OT** notations;
- Suspension of the **CYR**, **CYR-IT** or **CYR-OT** notations for more than a given period (i.e. 3 months);
- Expiry or withdrawal of class.

#### 1.4 Scope

##### 1.4.1 (1/1/2019)

The requirements in this section apply to ships having onboard CBS connected in networks, which can be vulnerable to cyber events potentially compromising the confidentiality, integrity and/or availability of information managed by means of such systems and networks.

##### 1.4.2 (1/1/2019)

The cyber events considered in this section are intentional or accidental unauthorized access, misuse, modification, destruction or improper disclosure of the information generated, archived or used in onboard CBS or transported in the networks connecting such systems.

##### 1.4.3 (1/1/2019)

For OT systems, the extent and level of application of the requirements in this section is to be adequate to the category of CBS considered, according to the definitions in IACS UR E22 [1.5.8] and repeated in Tab 1 for quick reference, considering the highest category of connected systems as leading.

##### 1.4.4 (1/1/2019)

For IT systems, Cat.I may be assumed, unless they are connected to OT systems, or otherwise prescribed on the basis

of Risk Assessment and FMEA. In case of IT systems connected to OT systems, item [1.4.3] applies and the highest category of connected systems shall be considered as leading.

#### **1.4.5** (1/1/2021)

The extent and level of application of the requirements shall take into account factors related to:

- a) The ship as a whole, like service notation, navigation notation, overall level of digitalization on board, extension and interconnection of different networks, etc.
- b) Function provided by the CBS, e.g. Control, Alarm, Monitoring, Communication etc., in decreasing order of priority.
- c) Type of service provided by the system the CBS is part of, e.g. Essential, Auxiliary Commodity or Entertainment services, in decreasing order of priority. In defining priority, availability of essential systems and of systems to remain operational for the safe operation of the ship shall be considered of highest priority. For OT systems, Cat.I, II and III ( Tab 1) may also be used for prioritizing.
- d) Severity of consequences of potential cyber events [1.4.2] affecting the CBS, ranked e.g. as Negligible, Minor, Moderate, Major or Catastrophic. Failure Mode Effect Analysis (FMEA) can be used to this purpose.
- e) Likelihood of occurrence of cyber events [1.4.2] affecting the CBS, ranked e.g. as High, Medium or Low. To this purpose, possible threats and countermeasures already in place shall be identified for the systems under consideration.

### **1.5 Reference regulations, guidelines, standards**

#### **1.5.1** (1/1/2019)

The following international or industrial standards, regulations and guidelines may be considered as a technical background for the requirements in this section.

#### **1.5.2** (1/1/2019)

IMO MSC-FAL.1/Circ.3, "Guidelines on Maritime Cyber Risk Management", July 2017.

#### **1.5.3** (1/1/2019)

ISO/IEC 27001:2013, "Information technology - Security techniques - Information security management systems - Requirements", 2013.

#### **1.5.4** (1/1/2019)

ISO/IEC 90003:2014, "Software engineering -- Guidelines for the application of ISO 9001:2008 to computer software", 2014.

#### **1.5.5** (1/1/2019)

NIST "Framework for Improving Critical Infrastructure Cybersecurity", version 1.1, April 2018.

#### **1.5.6** (1/1/2019)

"The Guidelines on Cyber Security On board Ships", version 2.0, BIMCO, CLIA, ICS, INTERCARGO, INTERTANKO, OCIMF and IUMI, 2017.

#### **1.5.7** (1/1/2019)

"The CIS Critical Security Controls for Effective Cyber Defense", version 6.0, Center of Internet Security, October 2015.

#### **1.5.8** (1/1/2019)

IACS UR E22 "On Board Use and Application of Computer Based Systems", June 2016.

#### **1.5.9** (1/1/2021)

ISA/IEC 62443 family of standards.

### **1.6 Definitions (See Note 1)**

#### **1.6.1** (1/1/2019)

Computer Based System (CBS): A programmable electronic device, or interoperable set of devices, organized for the collection, processing, maintenance, use, sharing, dissemination, or disposition of information. CBS onboard include IT and OT systems.

#### **1.6.2** (1/1/2019)

CyberSafety: The activity or process, ability or capability, or state whereby computer based systems are designed, built, operated, and maintained so as to allow only predictable, repeatable behaviors, in those areas of operation that can affect safety of life, property and the environment.

#### **1.6.3** (1/1/2019)

Cybersecurity: The activity or process, ability or capability, or state whereby computer based systems and the information contained therein are protected from and/or defended against damage, unauthorized use or modification, or exploitation.

#### **1.6.4** (1/1/2019)

Information Technology (IT) system: Any equipment or interconnected system or subsystem of equipment that is used in the automatic acquisition, storage, manipulation, management, movement, control, display, switching, interchange, transmission, or reception of data or information.

#### **1.6.5** (1/1/2019)

Operational Technology (OT) system: Any equipment or interconnected system or subsystem of equipment that is used to control processes such as manufacturing, product handling, production, and distribution. When referred to CBS onboard ships, the processes controlled by OT systems can be relevant to ship services such as propulsion, cargo control, steering, etc.

Note 1: The definitions are based on corresponding entries in NIST SP 800-53 Rev.4 (Glossary) and adapted to the specific context of computer based systems onboard ships.

### **1.7 Documents to be submitted**

#### **1.7.1** (1/1/2019)

The documents listed in Tab 1 are to be submitted to the Society by the Owner.

#### **1.7.2** (1/1/2019)

As an alternative to the above, equivalent documentation can be provided to the Society in the form of a single document, hereafter referred to as the ship's "Cyber Resilience Manual".

**1.7.3 (1/1/2019)**

The form and content of documents or the Cyber Resilience Manual are described in the following paragraphs [2] to [10] and a template of the Manual can be requested to the Society.

**1.7.4 (1/1/2019)**

The Company shall keep the documentation up to date and in line with the changes made to the CBS onboard, network configuration, software updates and other maintenance activities.

**1.7.5 (1/1/2019)**

The Society reserves the right to require additional information and/or documentation.

## 2 Identification

### 2.1 Inventory

**2.1.1 (1/1/2021)**

An inventory of the CBS onboard the ship and relevant networks to be considered for the assignment of class notation shall be provided to the Society by the Shipyard/System Integrator and kept up to date by the Company, either as a separate document or as part of the Cyber Resilience Manual, retained onboard and made available to the Surveyor for inspection. The inventory shall contain:

- a) The list of computer based systems, subsystems and programmable devices onboard the ship, with a short description of technical features and specific function for each.
- b) The category of each item identified in a), according to [1.4.3] and [1.4.4]
- c) A map describing the topology of each digital network connecting the items identified in a), including the intended function of each item, the main features of each network (e.g. protocols used) and communication data flows in all intended operation modes.
- d) A map describing the physical layout of each digital network connecting the items identified in a), including the physical location of the items onboard, the paths of network cables (for wired networks) or the position of wireless transmitters and receivers (for wireless networks), and the physical location of network access points.
- e) The list of software application programs, operating systems (if any), firmware and other software components installed on each item identified in a), including version numbers, maintenance policy (e.g. on-site vs. remote, periodic vs. occasional, etc.) and responsible persons.

**2.1.2 (1/1/2019)**

The following CBS, if present onboard, are to be included in the inventory:

a) for **CYR-OT**:

- Propulsion and Fuel Oil system
- Steering system
- Main source of electrical power
- Alarm Systems
- Control Systems
- Safety Systems
- Navigation Systems
- ESD (Emergency Shut Down) system
- Emergency source of electrical power
- UPS (Uninterruptable Power Supplies)
- Internal and external communication systems
- Fire extinguishing systems
- Safety center control system
- Bilge and ballast systems
- Heeling pumps
- Valves control and monitoring
- Power-operated watertight and semi-watertight doors
- Fire doors
- Flooding detection system
- Sanitation
- Grey Water system
- Refrigeration of food
- Lighting
- Ventilation and air conditioning
- Lifts
- Any other system whose disruption or functional impairing may pose risks at ship operation (e.g. LNG monitoring and control system, relevant gas detection system etc.)

b) for **CYR-IT**:

- Specific Hotel services (e.g. Laundry, Galley)
- HVAC
- Ship Owner Network
- Performance monitoring systems
- Networks and devices used for update of data on onboard systems (e.g. ECDIS).

**2.1.3 (1/1/2021)**

An inventory of roles and nominated persons (if available) that are granted to have access to the CBS and network infrastructure, either onboard the ship or from other location, shall be provided. The inventory shall contain:

- a) The roles and responsibility of persons granted to access the CBS and network infrastructure onboard, e.g. Administrator, Operator, Maintainer, etc. with a description of access rights, e.g. Read Only, Modify, Add, Delete, etc. If available, also the names of nominated persons shall be included and kept up to date. Seafarers, personnel internal to the Company and other personnel



not part of the Company (e.g. Suppliers) shall be considered.

- b) The access points they are allowed to access for connecting to the network(s), either onboard the ship or in other location.
- c) The time period for which their access is granted.

**Table 1 : Documents to be submitted (1/1/2021)**

No.	A/I (1)	Document	Ref.	Notation
1	I	Inventory of computer based systems onboard and roles/persons granted for access to the CBS onboard and network infrastructure	2.1	All
2	I	Vulnerability and threat assessment	3, 4	All
3	A	Risk Assessment	5	All
4	I	Protection safeguards	6	All
5	I	Detection safeguards	7	All
6	I	Response and recovery measures and procedures	8	All
7	I	Test	9	All
8	I	Maintenance	10	All
(1) A: to be submitted for approval I: to be submitted for information				

### 3 Vulnerability assessment

#### 3.1

##### 3.1.1 (1/1/2019)

A vulnerability assessment shall be carried out for the systems exposed to higher risk, based on criteria described in paragraphs [1.4.3] to [1.4.5] .

##### 3.1.2 (1/1/2019)

The vulnerability assessment shall be carried out at least for all OT systems of Cat II and III ( Tab 1) and systems connected thereto.

##### 3.1.3 (1/1/2019)

The vulnerability assessment shall be carried out for IT systems connected to OT systems, either permanently or temporarily, e.g. during maintenance of CBS onboard.

##### 3.1.4 (1/1/2021)

The vulnerability assessment shall be carried out by personnel with specific skills and demonstrated expertise. The level of investigation and extension/depth of tests shall be in accordance with the criteria described in paragraphs [1.4.3] to [1.4.5].

##### 3.1.5 (1/1/2019)

Vulnerabilities shall be identified also taking into account available knowledge bases and/or audits of similar systems.

##### 3.1.6 (1/1/2019)

A scoring system (e.g. the "Common Vulnerability Scoring System" - CVSS) may be used to communicate the characteristics and impacts of vulnerabilities, and produce a numerical score reflecting their severity.

##### 3.1.7 (1/1/2021)

During the design phase, vulnerability assessment shall be based on available knowledge bases and experience on similar designs, taking into account the functional requirements and specifications of the ship and of CBS onboard.

##### 3.1.8 (1/1/2021)

During the ship building phase, vulnerability assessment shall be updated by the Shipyard/System Integrator, taking into account possible variations of the original design and newly discovered vulnerabilities not known from the beginning, and can be limited to the assessment of individual components or pre-assembled subsystems.

##### 3.1.9 (1/1/2021)

After completion of the building phase, and before delivery, vulnerability assessment shall be carried out by the Shipyard/System Integrator considering the complete configuration of IT and OT systems onboard with relevant connections and interfaces in their operational conditions. The final vulnerability assessment shall be based on experience and results obtained thanks to the assessments carried out during the building phase and take into account the additional complexity and new interactions among subsystems due to integration and final configuration.

##### 3.1.10 (1/1/2021)

During the operational life of the ship, a plan for periodic vulnerability scans and security audits shall be defined by the Company. The plan shall consider also the repetition of vulnerability scans after maintenance activities, or changes in the network configuration, or in CBS, where deemed necessary. Shall new vulnerabilities be identified during the operational life of the ship, the Company shall update existing, or implement new relevant safeguards and risk mitigation measures.

**3.1.11 (1/1/2021)**

The outcomes of the vulnerability assessment carried out after completion of the building phase shall be made available by the Shipyard/System Integrator to the Company and provided to the Society for information, either as a separate document or as part of the Cyber Resilience Manual, retained onboard and made available to the Surveyor during inspection.

## 4 Threat assessment

### 4.1

**4.1.1 (1/1/2019)**

A threat assessment shall be carried out for the systems exposed to higher risk, based on criteria described in paragraphs [1.4.3] to [1.4.5].

**4.1.2 (1/1/2019)**

The threat assessment shall be carried out at least for all OT systems of Cat II and III of Tab 1 and systems connected thereto.

**4.1.3 (1/1/2019)**

The threat assessment shall be carried out for IT systems connected to OT systems, either permanently or temporarily, e.g. during maintenance of CBS onboard.

**4.1.4 (1/1/2021)**

The threat assessment shall be carried out by personnel with specific skills and demonstrated expertise, in cooperation with the Shipyard/System Integrator, the Company and other interested stakeholders. The level of investigation shall be in accordance with the criteria described in paragraphs [1.4.3] to [1.4.5].

**4.1.5 (1/1/2019)**

Threats shall be identified taking into account at least:

- a) The vulnerabilities found on systems.
- b) Potential threat actors, including e.g. nation states; terrorists; cyber criminals; organized crime; competitors; activist groups; careless, disgruntled or malicious insiders; cyber vandals; opportunists; unaware passengers; and others.
- c) Different purposes and interests for each possible threat actor.
- d) Their offensive capability and the probability of an attack, either intentional or accidental, that may depend on the ship type, operation, navigation, cargo, etc.
- e) Available knowledge bases and/or audits of similar systems.

**4.1.6 (1/1/2021)**

During the design phase, threat assessment shall be based on available knowledge bases and experience on similar

designs, taking into account the functional requirements and specifications of the ship and of CBS onboard.

**4.1.7 (1/1/2021)**

During the ship building phase, threat assessment shall be updated by the Shipyard/System Integrator, taking into account possible variations of the original design and newly discovered threats not known from the beginning.

**4.1.8 (1/1/2021)**

After completion of the building phase, the outcomes of the threat assessment shall be made available by the Shipyard/System Integrator to the Company and provided to the Society for information, either as a separate document or as part of the Cyber Resilience Manual, retained onboard and made available to the Surveyor during inspection.

**4.1.9 (1/1/2021)**

During the operational life of the ship, a plan for periodic update of threat assessment shall be defined by the Company. The threat assessment shall be updated considering newly available information on cyber incidents occurred in the marine sector and possible significant changes in capability, resources, knowledge and motivation of potential threat actors. shall new threats be identified during the operational life of the ship, the Company shall update existing, or implement new risk mitigation measures.

## 5 Risk assessment

### 5.1

**5.1.1 (1/1/2021)**

A risk assessment shall be carried out by the Company in cooperation with other interested stakeholders for the all systems identified in [2.1.2]. Systems can be grouped in homogeneous sets or by categories according to Pt C, Ch 3, Sec 3, Tab 1 (Cat. I, II, III).

**5.1.2 (1/1/2019)**

Risk assessment shall consider likelihood of occurrence (probability) vs. safety and security impacts (severity) resulting from the exposure or exploitation of vulnerabilities identified in [3] and threats identified in [4].

**5.1.3 (1/1/2019)**

A risk matrix can be used to rate risks, e.g. like the one shown in the ALARP Table, below. Measures adopted to mitigate risks to the level deemed acceptable to the Company shall be indicated. The risks lying in the Tolerable area (green) do not require any further mitigation. The risks lying in the Intolerable area (red) must be mitigated irrespective of the costs. The risks lying in the ALARP (As Low As Reasonably Practicable) area (yellow) are considered acceptable when the Company deems not cost-effective to implement additional mitigation measures.

Table 2 : ALARP table (1/1/2021)

SEVERITY					PROBABILITY				
Rating	People	Safety	Environment	Reputation	Never heard of	Heard of	Occurred	Occurred several time/year	Occurred several time/year in the ship
0	No injury	No effect	No effect	No impact	1 (1)	2 (1)	3 (1)	4 (1)	5 (1)
1	Slight injury	Slight effect	Slight effect	Slight impact	2 (1)	3 (1)	4 (1)	5 (1)	6 (2)
2	Minor injury	Minor effect	Minor effect	Limited impact	3 (1)	4 (1)	5 (1)	6 (2)	7 (2)
3	Major injury	Localised effect	Localised effect	Considerable impact	4 (1)	5 (1)	6 (2)	7 (2)	8 (3)
4	Single fatality	Major effect	Major effect	Major national	5 (1)	6 (2)	7 (2)	8 (3)	9 (3)
5	Multiple fatalities	Massive effect	Massive effect	Major international	6 (2)	7 (2)	8 (3)	9 (3)	10 (3)
(1) Tolerable (2) Acceptable (3) Intolerable									

#### 5.1.4 (1/1/2021)

During the design phase, risk assessment shall be based on available knowledge bases and experience on similar designs, taking into account the functional requirements and specifications of the ship and of CBS onboard.

#### 5.1.5 (1/1/2021)

During the ship building phase, risk assessment shall be updated by the Shipyard/System Integrator, taking into account possible variations of the original design and newly discovered threats and/or vulnerabilities not known from the beginning. Shall new risks be identified, the Shipyard/System Integrator shall update existing, or implement new risk mitigation measures according to the principles and methodology in [5.1.2] and [5.1.3].

#### 5.1.6 (1/1/2021)

After completion of the building phase, the outcomes of the risk assessment shall be made available by the Shipyard/System Integrator to the Company and provided to the Society for approval, either as a separate document or as part of the Cyber Resilience Manual, retained onboard and made available to the Surveyor during inspection.

#### 5.1.7 (1/1/2021)

During the operational life of the ship, the Company shall update the Risk Assessment taking into account the constant changes in the cyber scenario and new weaknesses identified in CBS onboard in a process of continuous improvement. Shall new risks be identified, the Company shall update existing, or implement new risk mitigation measures according to the principles and methodology in [5.1.2] and [5.1.3].

## 6 Protection safeguards

### 6.1 General

#### 6.1.1 (1/1/2021)

Protection safeguards shall be implemented by the Shipyard/System Integrator and the Company aimed to prevent the occurrence of adverse cyber events [1.4.2] on onboard CBS and networks. The level and extent of implementation shall be in accordance to the criteria described in paragraphs [1.4.3] to [1.4.5].

#### 6.1.2 (1/1/2019)

Protection safeguards shall be clearly described in a separate document or in a dedicated section of the Cyber Resilience Manual that shall be provided to the Society for information, retained onboard and made available to the Surveyor during inspection.

### 6.2 Access control

#### 6.2.1 (1/1/2021)

Technical means for the implementation of access control to CBS onboard, aimed at limiting the access to authorized users, processes or devices, and for authorized activities only, shall be foreseen in the design phase and implemented by the Shipyard/System Integrator during the ship building phase.

#### 6.2.2 (1/1/2021)

During ship operation, a policy for effective access control to CBS onboard shall be established and implemented by the Company, aimed at limiting the access to authorized users, processes or devices, and for authorized activities only, based on the technical means made available as per [6.2.1].

**6.2.3 (1/1/2021)**

The technical means and access control policy shall address at least the following aspects:

- a) Management of credentials (e.g. usernames and passwords), including periodical expiration and non-repetition; use of unnecessary administrative profiles; use of credentials available to groups of persons (e.g. forbid one common account for maintenance of all systems).
- b) Management of physical access to onboard network access points, including access recording logs and control of connection ports and drives for removable storage devices.
- c) Management of remote access to onboard systems, including enforced access control methods (e.g. multi-factor authentication), limited and explicitly agreed time windows for remote access, etc.
- d) Implementation of least-privilege policies
- e) Bring-your-own-device (BYOD) management policy, including notification to users of the Acceptable Use Policy of onboard facilities.

**6.2.4 (1/1/2019)**

Procedures for testing the actual and effective implementation of protection safeguards adopted shall be clearly described in order to allow the Surveyor to execute such procedures to his/her satisfaction during inspection. The Surveyor may require additional or alternative tests if deemed necessary.

**6.3 Network protection**

**6.3.1 (1/1/2021)**

Technical means for the implementation of network protection, shall be foreseen in the design phase and implemented during the ship building phase. These technical means shall address at least the following items:

- a) Network segregation, in particular separation between OT and IT networks
- b) Firewalling
- c) Use of so-called de-militarized zones
- d) Selection/control of IP addresses
- e) Implementation of Intrusion Prevention Systems (IPS)
- f) WiFi hardening
- g) Use of controlled Virtual Private Networks (VPN), etc. as applicable.

**6.3.2 (1/1/2021)**

During ship operation, technical and procedural measures shall be implemented by the Company for protecting the network, based on the technical means made available as per [6.3.1].

**6.4 Data protection**

**6.4.1 (1/1/2021)**

Devices used to store data used in CBS onboard shall be appropriate for the intended use and suitable for the marine environment, according to relevant regulations, e.g. IEC Performance Standards. Storage devices shall allow the implementation of a policy for data security as per [6.4.2].

**6.4.2 (1/1/2021)**

During ship operation, a policy for the effective data security shall be established and implemented, aimed at preserving the confidentiality, integrity and availability of data used by CBS onboard and relevant networks.

**6.4.3 (1/1/2019)**

The data security policy shall cover at least the following aspects:

- a) Redundancy of storage devices to protect data in the case of a drive single failure, e.g. RAID storage or equivalent. Redundancy of storage devices is mandatory for data used for Cat. II or Cat. III OT systems.
- b) Availability of spare compatible storage devices on board.
- c) Sanity check of removable/portable storage devices brought on-board the vessel against data corruption or malware infection before connection to onboard systems and networks.
- d) Encryption for data at rest (stored) and data in transit (exchanged)
- e) Integrity checks for data at rest and data in transit
- f) Data backup procedures
- g) Secure disposal of storage devices.

**6.5 Awareness and training**

**6.5.1 (1/1/2019)**

Cybersecurity awareness education and training shall be provided by the Company to the onboard personnel and possible other stakeholders to perform their cybersecurity-related duties and responsibilities consistent with related policies, procedures, and agreements.

**6.5.2 (1/1/2019)**

Drills and training updates, or equivalent, shall be provided aimed at maintaining and verifying the training.

**6.5.3 (1/1/2019)**

An acceptable use policy of the cyber resources available onboard shall be established by the Company and notified to persons other than onboard personnel having access to onboard networks (e.g. passengers).

**7 Detection safeguards**

**7.1 General**

**7.1.1 (1/1/2021)**

Detection safeguards shall be implemented by the Shipyard/System Integrator and the Company aimed to a timely detection and identification of cyber events [1.4.2] on onboard CBS and networks. The level and extent of implementation shall be in accordance to the criteria described in paragraphs [1.4.3] to [1.4.5].

**7.1.2 (1/1/2019)**

Roles relevant to detection safeguards shall be assigned and procedures defined.

**7.1.3 (1/1/2019)**

Detection safeguards shall be described in a separate document or in a dedicated section of the Cyber Resilience Man-

ual that shall be provided to the Society, retained onboard and made available to the Surveyor during inspection.

## 7.2 Monitoring of normal operation

### 7.2.1 (1/1/2021)

Technical means for the monitoring of CBS normal operation shall be foreseen in the design phase and implemented by the Shipyard/System Integrator during the ship building phase, based on an analysis of the system and network baseline operation and expected data flows.

### 7.2.2 (1/1/2021)

OT systems of Cat. II and III and IT systems connected to OT systems shall be designed, implemented and installed by the Shipyard/System Integrator to allow continuous and/or on-demand self-diagnostics. A description on how system or network abnormal operation can be detected shall be provided, if not self-evident.

### 7.2.3 (1/1/2021)

Connection quality and/or network performance monitoring tools shall be made available at least on networks connecting OT systems of Cat. II and III and on networks connecting IT systems to OT systems.

## 7.3 Real-time detection of cyber events

### 7.3.1 (1/1/2019)

Intrusion Detection Systems (IDS) shall be provided at least on networks with connection to shore or freely accessible access points.

### 7.3.2 (1/1/2019)

Malicious code detection tools, e.g. antivirus, antimalware, etc., shall be provided on systems connected to networks with connection to shore or freely accessible access points.

### 7.3.3 (1/1/2021)

Means shall be made available to display cyber events [1.4.2] in a timely, informative and unambiguous manner, including abnormal operation as per [7.2], attempts of unauthorized access to CBS, unauthorized maintenance, attempts to alter data or code, etc.

## 7.4 Offline auditing

### 7.4.1 (1/1/2021)

Means for recording cyber events shall be made available, aimed at allowing the examination of all the events detected by the above listed safeguards on a given period of time (e.g. one week, one month, ...). Event log auditing shall be carried out, either periodically or after detection of cyber event [1.4.2] by personnel with specific skills and demonstrated expertise.

## 8 Response and recovery measures and procedures

### 8.1 General

#### 8.1.1 (1/1/2021)

Response and recovery measures and procedures shall be implemented by the Company aimed to take appropriate actions regarding detected cyber events [1.4.2] on onboard CBS and networks. The level and extent of implementation

shall be in accordance to the criteria described in paragraphs [1.4.3] to [1.4.5].

#### 8.1.2 (1/1/2019)

Response measures and procedures shall be described in a separate document or in a dedicated section of the Cyber Resilience Manual that shall be provided to the Society, retained onboard and made available to the Surveyor during inspection.

#### 8.1.3 (1/1/2021)

The Shipyard/System Integrator shall provide to the Company all the documentation relevant to the technical means for the detection of cyber events [1.4.2] on onboard CBS and networks and for the implementation of appropriate response and recovery measures and procedures.

## 8.2 Response and recovery plan

### 8.2.1 (1/1/2021)

Based on the vulnerability and threat assessment [3], [4], a response plan for the effective and timely response to possible cyber events [1.4.2] shall be provided by the Company, aimed at limiting as much as possible the extension and duration of consequences and restore the relevant services to the ship.

### 8.2.2 (1/1/2019)

The response and recovery plan shall cover at least the following aspects:

- a) Clear description of alerts for a timely acknowledgement of cyber events
- b) Step-by-step procedures for the isolation, exclusion, backup, replacement by redundant system, manual/local operation, shutdown, reset, restart or other measure to be adopted for the CBS and/or networks affected by the cyber event
- c) Step-by-step procedures for the recovery of data managed by CBS and/or networks affected by the cyber event
- d) Assignment of roles, responsibilities and tasks to onboard personnel involved in the response procedures
- e) Instruction for timely and effective information to and communication with responsible personnel.

## 8.3 Training

### 8.3.1 (1/1/2021)

Training of personnel and drills shall be planned by the Company, in order to ensure that the expected Response Time Objectives and Response Target Objectives can be reached.

## 9 Test

### 9.1

#### 9.1.1 (1/1/2019)

Procedures for verifying the actual and effective implementation of safeguards and measures described in paragraphs [6 to 8] shall be clearly described in relevant documentation in order to allow the Surveyor to execute such procedures to his/her satisfaction during inspection.

**9.1.2 (1/1/2021)**

The Company shall keep up-to-date documentation on test procedures and make such documentation available to the attending Surveyor.

**9.1.3 (1/1/2019)**

The Surveyor may require additional or alternative tests if deemed necessary.

## **10 Maintenance**

### **10.1**

**10.1.1 (1/1/2019)**

The Company shall establish procedures for the maintenance of CBS onboard, e.g. software updates. The following aspects shall be covered:

- a) Roles and responsibilities: personnel involved in maintenance activities
- b) Initiation: the circumstances, or events, that may trigger a maintenance activity
- c) Planning: a description of the activities to be carried out, conditions to be met and arrangements to be made for the maintenance to be performed.
- d) Execution: a description of how the maintenance activity is actually carried out.
- e) Test: a description of acceptance tests (Factory Acceptance Tests (FAT), Site Acceptance Tests (SAT), User Acceptance Tests (UAT), etc. as applicable) to be per-

formed aimed at verifying the success of the maintenance activity. Acceptance tests shall include functional, regression and performance tests. An explanation of how to check the current software/firmware version installed on the CBS subject to maintenance shall be also included.

- f) After-service: how to provide information to the personnel responsible of or using the CBS subject to maintenance.
- g) Rollback: a description of how to restore the CBS to a safe status in case of failure of the maintenance activity.

**10.1.2 (1/1/2019)**

A record of maintenance activities shall be kept up to date. Acceptance tests results shall be recorded.

**10.1.3 (1/1/2019)**

The maintenance procedures shall be documented in a separate document or in a dedicated section of the Cyber Resilience Manual that shall be provided to the Society, retained onboard and made available to the Surveyor during inspection.

**10.1.4 (1/1/2019)**

In case of major maintenance activities, the Company shall inform the Society. The Society reserves the right to verify the conditions for the maintenance of **CYR**, **CYR-OT** or **CYR-IT** notations.

## SECTION 30

## DIGITAL SHIP (ADC)

### 1 General

#### 1.1 Application

##### 1.1.1 (1/1/2023)

The additional class notation **DIGITAL SHIP (ADC)** is assigned to ships complying with the requirements of this section. In particular, it is assigned to ships fitted with an automatic data collection system enabling the collection of navigation and machinery data and capable of transferring data (either as collected or after the necessary elaboration) ashore, allowing the continuous monitoring of the ship through at least the minimum set of parameters described in this Section.

A Certificate of Compliance may be issued to ships not classed with the Society, fulfilling the requirements of this section.

### 2 Definitions

#### 2.1

##### 2.1.1 (1/1/2019)

- Data Collector is an electronic system that performs a systematic recording of signals from sensors and equipment installed on board and information manually provided.
- Data Point is a complete set of collected and filtered data over a period not greater than 10 minutes.
- Data Storage is the operation of saving and retention of recorded data. Previously stored data are to be kept together with new data, ordered in a sequence so that their retrieval can be easily performed.
- Owner, in this section, means Ship Owner or Ship Management Company.
- Parameter is the variable which value is collected and recorded by the data collector.
- Recorded data is the representative value of the parameter obtained, depending from the nature of the parameter, as a mean value or a single representative value of collected data in a time frame.
- Representative Value is a processed Data Point stored.
- cloud platform to analyse collected data.
- Time stamp is the data reference time expressed in UTC.

### 3 Documents to be submitted

#### 3.1

##### 3.1.1 (1/1/2023)

The following documents are to be submitted for information:

- list of bridge collected signals,
- list of machinery collected signals,
- list of signals transferred ashore.

Depending on the ship arrangement and on the data collection system architecture, additional drawings or documents may be required at Society's discretion.

### 4 Requirements

#### 4.1 General

##### 4.1.1 (1/1/2019)

The ship is to be fitted with an automatic data collector capable to transfer data to Cube.

##### 4.1.2 (1/1/2023)

The minimum set of parameters that the data collector is to be capable of collecting, recording and transferring (either as collected or after the necessary elaboration) ashore and/or to Cube platform is listed in [4.2].

#### 4.2 Data to be collected, recorded and transferred by the data collector

##### 4.2.1 Bridge/navigation data (1/1/2019)

- GPS (position, speed over ground, course over ground)
- Gyrocompass (Heading )
- Speed log (speed through water)
- Anemometer (Wind speed and direction, true or relative)
- Loading condition (Draft, Displacement).

##### 4.2.2 Machinery data (1/1/2019)

- Shaft(s) RPM
- Shaft(s) power)
- Propeller(s) Pitch (if applicable)
- Main Engine(s) fuel consumption (if applicable, i.e. for diesel propulsion)
- Main Engine(s) status (on/off)
- Shaft(s) generator(s) power (if any)
- Diesel Generator(s) power
- Diesel Generator(s) fuel consumption
- Main Engine(s) fuel type in use (if applicable, i.e. for diesel propulsion)
- Diesel Generator(s) fuel type in use.

### 4.3 Minimum Data Acquisition Rate

#### 4.3.1 (1/1/2019)

Automatic data collection is to be continuous so as to allow the identification of a representative value for a time frame, in accordance with [4.4].

### 4.4 Recorded Data (Representative Value and Time Stamp)

#### 4.4.1 (1/1/2019)

Automatic data collection is to be continuous so as to allow the identification of a representative value for a time frame, in accordance with [4.4].

#### 4.4.2 (1/1/2019)

Data Point for each Parameter is to be processed to identify a Representative Value that, along with the reference Time stamp, will be the Recorded data. The time frame between two Representative Values is not to be greater than 10 minutes.

### 4.5 Storage Requirements

#### 4.5.1 (1/1/2019)

All Representative Values are to be stored along with the Time stamps indicating the time when the Representative Value was made.

A back up facility of all stored data is to be foreseen.

Being the data collection system installed on board, the backup facility is to be located elsewhere.

Access to the data is to be logged, controlled and secured by the Owner.

### 4.6 Interface

#### 4.6.1 (1/1/2023)

The automatic data collection system is to be capable of submitting the collected data to the cloud platform Cube or, alternatively, to an Owner's cloud. Collected data submitted to Cube will be accessible to the Owner only.

In both cases, the collected data are to be made available to Tasneef for the time necessary to perform the assessment and verifications needed to maintain the **DIGITAL SHIP (ADC)** class notation.

## 5 General

### 5.1 Application

#### 5.1.1 (1/1/2019)

In case of ship not classified by the Society or upon Owner's request, a certificate of compliance to the requirements of this section may be issued.

The certificate is valid for a period of 5 years, subject to annual confirmation.



## SECTION 31

## AIR LUBRICATION SYSTEM (AIR LUB)

### 1 Scope and application

#### 1.1

##### 1.1.1 (1/4/2019)

The additional class notation **AIR LUB** is assigned, in accordance with Pt A, Ch 1, Sec 2, [6.14.47], to ships with an air lubrication system complying with the requirements of this Section.

This Section provides requirements on the design, installation and testing of air lubrication systems on new and existing ships with regard to hull, stability and machinery, including ventilation, piping, air compressor and receivers, main power and electrical systems, control, monitoring alarm and safety systems.

This Section is applicable to air lubrication technologies - such as air bubble, air layer and air cavity methods - which use air bubbles to reduce the skin friction resistance, with the main difference being the air distributor design.

Alternative arrangements, designs and technologies may be accepted on a case-by-case basis provided that they meet the overall requirements of this Section.

### 2 Documents to be submitted

#### 2.1

##### 2.1.1 (1/4/2019)

The documents listed in Tab 1 are to be submitted.

These documents are intended to be relevant to the air lubrication system, unless otherwise specified.

The list of documents requested is to be intended as guidance for the complete set of information to be submitted, rather than an actual list of titles.

The Society reserves the right to request the submission of additional documents in the case of non-conventional design or if it is deemed necessary for the evaluation of the system, equipment or components.

Unless otherwise agreed with the Society, documents for approval are to be sent in triplicate if submitted by the Shipyard and in four copies if submitted by the equipment supplier. Documents requested for information are to be sent in duplicate. In any case, the Society reserves the right to require additional copies when deemed necessary.

**Table 1 : Documents to be submitted (1/4/2019)**

No.	A/I (1)	Documents
1	I	General arrangement and detail specification
2	A	Air distributors structure drawings, including connections to the ship structure
3	A	Ship electrical load balance
4	A	Single line diagram and circuit booklet
5	A	Detailed diagram of the motor starters
6	A	Valve control system diagram
7	A	Piping system schematic diagram including valves and piping material specifications
8	A	Stability information (in case of retrofitting, e.g. additional weight and relevant position)
9	A	Detail design of air distributors
10	A	Detail design of air receivers
(1) A: to be submitted for approval I: to be submitted for information		

### 3 Design requirements

#### 3.1 Hull

##### 3.1.1 (1/4/2019)

The structure of air distributors and their connections to the outer hull plating, ordinary stiffeners and/or primary sup-

porting members are to be designed in accordance to the requirements of Part B, Chapter 7, taking into account the local and hull girder loads described in Part B, Chapter 5.

**3.1.2 (1/4/2019)**

The resulting openings in way of the air distributors may affect the longitudinal strength.

The effective areas of the affected sections to calculate the hull girder section modulus and stresses are to be taken into account according to the requirements in Pt B, Ch 6, Sec 1.

**3.1.3 (1/4/2019)**

When, the resulting openings in the air distributors are deemed of particularly extended dimensions, the local stress concentrations due to the openings are to be assessed so that they meet the applicable strength requirements in Pt B, Ch 7, Sec 3.

On a case by case basis, also fatigue checks according to Pt B, Ch 7, Sec 4 may be required for unusual structural configurations of the connections and/or particularly extended dimensions of the resulting openings.

Where necessary, insert plates of increased thickness intended to compensate the lost cross sectional area are to be foreseen.

**3.1.4 (1/4/2019)**

All openings in the outer hull are to have well-rounded corners as required in Pt B, Ch 4, Sec 3.

**3.2 Stability**

**3.2.1 (1/4/2019)**

Ships fitted with an air lubrication system are to comply with the intact stability requirements in Part B, Chapter 3.

**3.3 Machinery**

**3.3.1 General (1/4/2019)**

An air lubrication system generally consists of compressors or blowers, piping, valves and control systems, and air distributors.

**3.3.2 Ventilation (1/4/2019)**

A ventilation system is required for equipment in the air lubrication machinery space. The ventilation system is to have sufficient air exchange capacity as defined in Pt C, Ch 1, Sec 1, [3.6] for proper machinery operation.

**3.3.3 Piping (1/4/2019)**

The piping of the air lubrication system is subject to the design requirements in Pt C, Ch 1, Sec 10 with the valves subject to the requirements in Pt C, Ch 1, Sec 10, [2.8].

Non return valves with positive means of closing are to be fitted above the double bottom in way of the passage of the air distribution pipes leading to the hull or air distributors and are to be controllable from a normally accessible position above the freeboard deck.

The piping between the hull and the non-return valve is to be of extra-reinforced wall thickness according to Pt C, Ch 1, Sec 10, Tab 5.

**3.3.4 Air compressor and receivers (1/4/2019)**

Air receivers for the air lubrication system are subject to the requirements in Pt C, Ch 1, Sec 3.

The air supply for the air lubrication system is to be independent of the starting and control air supply and reserve.

Means to indicate the contamination of the air with oil are to be arranged.

**3.3.5 Electrical installations (1/4/2019)**

The electrical installations and relevant electrical components for air lubrication system are to be designed and constructed according to the requirements in Part C, Chapter 2.

An air lubrication system is to be considered a service among those listed in Pt C, Ch 2, Sec 3, [2.2.5].

**3.3.6 Control, Monitoring, Alarm and Safety Systems (1/4/2019)**

Automatic control, alarm, and safety functions are to be provided for the air lubrication system so that the operations remain within the preset parameters for different operation conditions.

The system is to be designed to avoid a single failure event leading to a potentially dangerous situation for human safety and/or the ship. In the event of air lubrication system failure, an alarm is to be activated.

**4 Installation requirements**

**4.1 Hull**

**4.1.1 (1/4/2019)**

Installation of an air lubrication system requires affixing air distributors to distribute air bubbles under the hull. This will require openings under the hull and in the outer shell to accommodate the air distribution system.

**4.1.2 (1/4/2019)**

The materials used to build the air distributors are to be verified as per the requirements in Pt D, Ch 2, Sec 1 (for steel plates sections and bars), Sec 3 (for steel forgings) or Sec 4 (for steel castings) as applicable. The workmanship is to comply with the requirements in Pt D, Ch 5, Sec 6.

**4.2 Machinery**

**4.2.1 (1/4/2019)**

The machinery space containing the compressors of the air lubrication system is to be designed to allow convenient access for maintenance and repair.

**5 Equipment testing requirements**

**5.1 Machinery**

**5.1.1 (1/4/2019)**

The piping system components of the air lubrication system are subject to the testing requirements in Pt C, Ch 1, Sec 10, [2.1].

**5.1.2 (1/4/2019)**

Pressure vessels are to be tested according to the requirements in Pt C, Ch 1, Sec 3.

**5.1.3 (1/4/2019)**

Test certificates for air compressors are to be provided by the manufacturer. In addition, a statement issued by the manufacturer attesting that the contamination with oil of the discharged air is 5 mg/m<sup>3</sup> or lower (reference is made to ISO 8573-1) is to be provided.

**5.1.4 (1/4/2019)**

Testing of electrical components are to be carried out according to the relevant requirements in Part C, Chapter 2, as applicable.

**6 Tests on board****6.1****6.1.1 (1/4/2019)**

The following tests and inspections are to be performed on board:

- check compliance of system and fittings with approved drawings,
- check of stability booklet (for retrofitting on existing ships),
- review of test certificates for components,
- visual inspection and tightness test of hull and water-tight boundaries' penetrations,
- visual inspection of piping system and operational test of valves,
- leakage test of piping,
- measurement of insulation resistance of electric plant,
- functional tests of the whole system under working condition, including its monitoring, alarm and safety systems,
- test of devices to prevent the return in safe space of atmosphere from the dangerous zone, if any.

## SECTION 32

## PERSONS WITH REDUCED MOBILITY (PMR-ITA)

### 1 General

#### 1.1 Application

##### 1.1.1 (13/12/2019)

The additional class notation **PMR-ITA** is assigned, in accordance with Pt A, Ch 1, Sec 2, [6.14.48] to ships complying with the requirements in this section.

#### 1.2 Assignment criteria

##### 1.2.1 (13/12/2019)

This class notations may be assigned to passenger ships and high-speed passenger crafts.

On voluntary basis, a Certificate of Compliance may be issued to ships not classed with the Society fulfilling the requirements of this Section.

#### 1.3 Scope

##### 1.3.1 (13/12/2019)

The requirements in this section apply to passenger ships and high-speed passenger crafts, to respond to anyone who has a particular difficulty when using public transport, including elderly persons, disabled persons, persons with sensory impairments and wheelchair users, pregnant women and persons accompanying small children.

For the purpose of safe access to all passenger ships by persons with reduced mobility, passenger ships and high-speed passenger crafts are to the extent possible be designed in such a way that a person with reduced mobility can embark and disembark easily and safely and that there is barrier free passage in public spaces on board and in escape routes to muster stations.

Crew members required to assist passengers who may need assistance, are to be instructed in the kind of assistance needed by persons with reduced mobility on board.

#### 1.4 Reference regulations, guidelines, standards

##### 1.4.1 (13/12/2019)

The following international or industrial standards, regulations and guidelines may be considered as a technical background for the requirements in this section.

- DIRECTIVE 2009/45/EC OF THE EUROPEAN PARLIAMENT AND OF THE COUNCIL of 6 May 2009 on safety rules and standards for passenger ships
- Italian "Decreto Legislativo 8 marzo 2005, n. 52" on safety rules and standards for passenger ships
- IMO circular MSC/735 of 24 June 1996 "Recommendation on the design and operation of passenger ships to respond to elderly and disabled persons' needs"
- Italian "Circolare n. 10/SM" of 4 January 2007 about application of safety requirements for passenger ships

and high-speed passenger craft related to persons with reduced mobility (PMR)

- Annex 2 of "Circolare n. 10/SM "Linee guida contenenti prescrizioni tecniche per agevolare l'accessibilità e la mobilità a bordo delle navi impiegate in viaggi nazionali marittimi da parte delle persone a mobilità' ridotta"
- Italian R.D. 20 maggio 1897, n. 178. "Approvazione del regolamento che stabilisce le condizioni speciali richieste nelle navi addette al trasporto dei passeggeri" and its amendments and additions.

#### 1.5 Definitions

##### 1.5.1 (13/12/2019)

- Persons with reduced mobility: means anyone who has a particular difficulty when using public transport, including elderly persons, disabled persons, persons with sensory impairments and wheelchair users, pregnant women and persons accompanying small children.
- Ships built after 1 October 2004: according to Italian "Decreto Legislativo 8 marzo 2005, n. 52" passenger ships and high-speed passenger crafts, the keel of which was laid or which were at a similar stage of construction on or after 1 October 2004.
- Ships built before 1 October 2004: according to Italian "Decreto Legislativo 8 marzo 2005, n. 52" passenger ships and high-speed passenger crafts, the keel of which was laid or which were at a similar stage of construction before 1 October 2004
- Italian "Circolare n. 10/SM" of 4 January 2007 about application of safety requirements for passenger ships and high-speed passenger craft related to persons with reduced mobility (PMR)
- New ships: according to Annex 2 of "Circolare n. 10/SM "Linee guida contenenti prescrizioni tecniche per agevolare l'accessibilità e la mobilità a bordo delle navi impiegate in viaggi nazionali marittimi da parte delle persone a mobilità' ridotta", passenger ships and high-speed passenger crafts, the keel of which was laid or which were at a similar stage of construction on or after 1 July 2013.
- Existing ships: according to Annex 2 of "Circolare n. 10/SM "Linee guida contenenti prescrizioni tecniche per agevolare l'accessibilità e la mobilità a bordo delle navi impiegate in viaggi nazionali marittimi da parte delle persone a mobilità' ridotta", passenger ships and high-speed passenger crafts, the keel of which was laid or which were at a similar stage of construction on or after 1 October 2004 but before 1 July 2013.

## 1.6 Documents to be submitted

### 1.6.1 (13/12/2019)

The documents listed in Tab 1 are to be submitted. The Society reserves the right to request the submission of additional documents if it is deemed necessary for the evaluation of the arrangement.

## 2 Requirements

### 2.1 Ships built after 1 October 2004

#### 2.1.1 (13/12/2019)

Ships built after 1 October 2004 have to comply with:

- DIRECTIVE 2003/24/EC OF THE EUROPEAN PARLIAMENT AND OF THE COUNCIL of 14 April 2003 amending Council Directive 98/18/EC on safety rules and standards for passenger ships - Annex III
- Italian "Circolare n. 10/SM" of 4 January 2007 about application of safety requirements for passenger ships and high-speed passenger craft related to persons with reduced mobility (PMR)
- Annex 2 of "Circolare n. 10/SM "Linee guida contenenti prescrizioni tecniche per agevolare l'accessibilità e la mobilità a bordo delle navi impiegate in viaggi nazionali marittimi da parte delle persone a mobilità ridotta"

### 2.2 Ships built before 1 October 2004

#### 2.2.1 (13/12/2019)

Ships built before 1 October 2004 have to comply with the following requirements.

#### 2.2.2 General requirements (13/12/2019)

The ship is to be equipped in such a way that that public spaces and escape routes to muster stations have barrier free passage for elderly and disabled persons.

A dedicated design assessment has to demonstrate that the goal for "existing ships" as described in Annex 2 of "Circ-

lare n. 10/SM "Linee guida contenenti prescrizioni tecniche per agevolare l'accessibilità e la mobilità a bordo delle navi impiegate in viaggi nazionali marittimi da parte delle persone a mobilità ridotta" is achieved or an equivalent solution is in place.

Main items to be considered are:

- Access to the ship
- Access to escape route
- List of PMR provided to the Master before the voyage
- Space on board for PMR
- PMR lavatories
- Restaurants and Cafeterias itinerant service, if any
- PMR vehicles embarkation and positioning onboard
- Signs.

#### 2.2.3 Training (13/12/2019)

Crew is to be trained:

- to operate with platforms or any other means of assistance for the PMR
- to perform necessary assistance to PMR (e.g during embarkation, positioning in public area, assistance for toilet, disembarkation, assistance in case of evacuation).

Crew dedicated to PMR assistance are to be indicated in muster list.

Training certificates are to be kept onboard and available for checking during inspection.

#### 2.2.4 Testing (13/12/2019)

Tests to check ship's accessibility by a PMR are to be carried out onboard, in particular to verify that, where a design assessment has been carried out, that the goal of the requirements described in Annex 2 of "Circolare n. 10/SM "Linee guida contenenti prescrizioni tecniche per agevolare l'accessibilità e la mobilità a bordo delle navi impiegate in viaggi nazionali marittimi da parte delle persone a mobilità ridotta" is achieved.

**Table 1 : Documents to be submitted (13/12/2019)**

No.	I/A (1)	Documents
1	I	Arrangement of PMR cabins, if any
2	I	Arrangement of public spaces with reference to PMR including toilet
3	I	Arrangement of onboard accessible routes with reference to PMR
4	I	Arrangement of signs to aid persons with reduced mobility (including persons with sensory disabilities)
5	I	Procedures to manage communications onboard
6	I	Training procedure for crew onboard to manage PMR and training certificates
7	I	Design assessment, if any

(1) A = to be submitted for approval in four copies; I = to be submitted for information in duplicate.

**SECTION 33****BIOSAFE SHIP****1 General****1.1 Application****1.1.1 (15/6/2020)**

The additional class notation **BIOSAFE SHIP** is assigned, in accordance with Pt A, Ch 1, Sec 2, [6.14.49], to:

- Cruise ships and ro-ro passenger ships with sleeping facilities for passengers
- Passenger ships, high-speed passenger craft and ro-ro passenger ships in short sea voyages
- Cargo ships

designed and provided with systems, components and operative procedures to control and prevent possible on board infection outbreak, in accordance with the requirements of [5].

**1.1.2 (1/1/2021)**

Upon request of the Parties entitled, a Certificate of Compliance may be issued to ships not classed with the Society, fulfilling the requirements of this section.

The Certificate of Compliance has a validity of 5 years subject to annual confirmation and renewal at the end of the validity period.

**2 Documents to be submitted****2.1****2.1.1 (15/6/2020)**

The general list of plans and documents to be submitted is given in Tab 1.

Plans and documents relating to systems, components and operative procedures not specific to this additional class notation need not be submitted.

The Society reserves the right to request the submission of additional documents in the case of non-conventional design or if it is deemed necessary for the evaluation of the systems and components.

**Table 1 : Documents to be submitted (15/6/2020)**

No.		Document
1	I	Health Management Plan
2	I	Maintenance plans of systems and equipment chosen from those listed in Tab 2
3	I	Plans and procedures as required by the risk minimization measure adopted according to App 3
4	I	Ship general arrangement plan with the indication of the location of the means adopted to minimize the risk of infection according to Tab 2
(1) I = to be submitted for information in duplicate.		

**3 Requirements****3.1 General requirements****3.1.1 (15/6/2020)**

A Ship Health Officer is to be appointed and present on board.

The Ship Health Officer is the Officer in charge of the management and control of the procedures and activities relevant to the requirements in this section.

**3.1.2 (15/6/2020)**

For ships whose journey leg is planned to be of less than 2 hours, the presence of the Ship Health Officer on board is not required.

**3.1.3 (15/6/2020)**

An Health Management Plan, specific to the ship, is to be made available on board.

The Plan is to contain at least:

- a) a risk assessment in normal operational conditions to identify risk and preventive actions to be adopted to minimize the possible outbreak of infection on board,
- b) a risk assessment in case of presence of infection on board to identify risks and actions to be adopted to contain the spread of the infection,
- c) plans and procedures as required by the risk minimization measure adopted according to App 3,
- d) detailed procedures for contact ashore authorities and hospitals facilities to coordinate assistance and transfer of infected persons.

**3.1.4 (15/6/2020)**

Adequate training on health issues in normal health and emergency health conditions is to be planned, carried out and documented for all the seafarers on board, in particular for those who might have influence on the monitoring, control and management of the health on board conditions.

Persons in charge for systems, components and operative procedures as listed in Tab 2 are to be properly trained. Relevant manuals for the use of the system, maintenance, including the management of any system fault or alarm, are to be included in the training documentation.

**3.2 Additional arrangements, systems and operative procedures****3.2.1 (15/6/2020)**

The list of additional arrangement, systems or components and operative procedures, which can be considered for the assignment of the notation and the values to be used for the calculation of the BIOSAFE index, as indicated in [4], are given in the third and fourth column of Tab 2, respectively.

**Table 2 : Additional systems, components and procedural means (1/1/2021)**

No.	Arrangement & Systems	Risk minimization measure	Value to calculate BIOSAFE index	Reference to requirements in App 3
1	Ship's General Arrangement	Allocation of a dedicated area for the containment of a possible infection outbreak	20	[1.1]
		Dressing and undressing areas	7	[1.2]
		Routes for medical care and containment areas	5	[1.3]
		Dedicated area onboard for health monitoring centre	10	[1.4]
		Routes for social distancing	5	[1.5]
		Routes for provision, luggage, spare parts management	5	[1.6]
		Working places	3	[1.7]
		Corridors, stairs and lifts	5	[1.8]
2	Cabins and rooms	Cabins with enhanced sanitation capability surfaces	7	[2.1]
		Rooms with fixed oxygen distribution	3	[2.2]
		Rooms with direct alarm to medical care	2	[2.3]
		Information videos	3	[2.4]
3	Public spaces	Touch free/hands free solutions for means of access	5	[3.1]
		Touch free/hands free solutions for public toilet	5	[3.2]
		Surfaces with high utilization rate designed for easy sanitation	3	[3.3]
		Surfaces with high utilization rate active materials or coatings	3	[3.4]
		Public space design	5	[3.5]
		Onboard payments	5	[3.6]
		Information videos	3	[3.7]
4	Prevention of contamination by surface	UV-C lamps for surface disinfection	7	[4.1]
		Fixed or portable sanitation system	10	[4.2]
		Store for sanitation and disinfection products	3	[4.3]
		Fixed sanitation system of dirty routes	10	[4.4]

No.	Arrangement & Systems	Risk minimization measure	Value to calculate BIOSAFE index	Reference to requirements in App 3
5	Prevention of contamination by air	HVAC system for containment area - independent system	15	[5.1]
		HVAC system for containment area – separated system	5	[5.2]
		HVAC system for containment area - under pressure isolation	7	[5.3]
		HVAC system - air disinfection by means UV-C lamp	7	[5.4]
		HVAC system - air disinfection by chemical agents	7	[5.5]
		HVAC system - air disinfection by filters	7	[5.6]
		Cabins - changes per hour	3	[5.7]
		Public spaces - changes per hour	3	[5.8]
		Cabin HVAC outlet	10	[5.9]
6	Prevention of contamination by fresh water system	FW disinfection by means UV-C lamp	3	[6.1]
		FW disinfection by means chemical agents	3	[6.2]
7	Prevention of contamination by grey water and sewage system	Grey water disinfection	3	[7.1]
		Sewage disinfection	3	[7.2]
8	Garbage Handling	Medical waste dedicated bins	2	[8.1]
		Contaminated waste management	3	[8.2]
9	Enhanced Medical Care	Intensive care unit	20	[9.1]
		Ventilators	5	[9.2]
		Totally enclosed stretcher	3	[9.3]
		Gastight coverall	3	[9.4]
10	Monitoring systems	People tracking system for social distancing monitoring	10	[10.1]
		Infected persons tracking system	10	[10.2]
		Gates for the automatic detection of potential affected people	8	[10.3]
		Containment areas monitoring	5	[10.4]
		Equipment for distributed mustering	10	[10.5]
		Behaviour monitoring	7	[10.6]

### 3.3 Applicable requirements

#### 3.3.1 (15/6/2020)

The applicable requirements for each additional arrangement adopted, systems or components installed and operative procedures implemented are given in App 3.

## 4 BIOSAFE index

### 4.1 Index calculation

#### 4.1.1 (15/6/2020)

The Biosafe index is obtained by adding up the values of the contributions for each additional system, component and operative procedures (items) the ship is equipped with, according to Tab 2.

No contribution to the Biosafe index or to coverage of the relevant arrangement / system will be given by the implementation of those arrangements, systems or components and operative procedures, specific for the prevention and control of the spread of infections, a ship is to be provided with to comply with IMO Conventions in force.

#### 4.1.2 (15/6/2020)

The implementation of the relevant arrangements, systems or components and operative procedures, specific for the prevention and control of the spread of infections, contributes to the Biosafe index and to coverage of the relevant arrangement / system), provided that the date of entry into force of IMO requirements (becoming mandatory before the delivery of the ship) is not yet known when the ship is contracted for construction or refitting.



## 5 Assignment criteria

### 5.1 Cruise ships and ro-ro passenger ships with sleeping facilities for passenger

#### 5.1.1 (15/6/2020)

The additional class notation **BIOSAFE SHIP** is assigned to cruise ships and ro-ro passenger ships with sleeping facilities for passenger complying with [3] and having adopted arrangements, systems or components and operative procedures selected from Tab 2, pertaining to at least 8 arrangement / system as listed in the second column of Tab 2 and having a Biosafe Index, calculated in accordance with [4.1] greater than or equal to 100.

#### 5.1.2 (15/6/2020)

Existing ships may adopt arrangements, systems or components and operative procedures selected from Tab 2, pertaining to at least 7 arrangement / system as listed in the second column of Tab 2 and having a Biosafe Index, calculated in accordance with [4.1] greater than or equal to 60.

### 5.2 Passenger ships and ro-ro passenger ships in short sea

#### 5.2.1 (1/1/2021)

The additional class notation **BIOSAFE SHIP** is assigned to passenger ships and ro-ro passenger ships in short sea voyages complying with [3] and having adopted arrangements, systems or components and operative procedures selected from Tab 2, pertaining to at least 7 or 6 (in the absence of cabins for passengers) arrangement / system as listed in the second column of Tab 2 and having a Biosafe Index, calculated in accordance with [4.1], greater than or equal to 60.

#### 5.2.2 (1/1/2021)

Existing ships may adopt arrangements, systems or components and operative procedures selected from Tab 2, pertaining to at least 6 or 5 (in the absence of cabins for passengers) arrangement / system as listed in the second column of Tab 2 and having a Biosafe Index, calculated in accordance with [4.1] greater than or equal to 40.

### 5.3 Cargo Ships

#### 5.3.1 (15/6/2020)

The additional class notation **BIOSAFE SHIP** is assigned to cargo ships complying with [3] and having adopted arrangements, systems or components and operative procedures selected from Tab 2, pertaining to at least 5 arrange-

ment / system as listed in the second column of Tab 2 and having a Biosafe Index, calculated in accordance with [4.1], greater than or equal to 50.

#### 5.3.2 (1/1/2021)

Existing ships may adopt arrangements, systems or components and operative procedures selected from Tab 2, pertaining to at least 5 arrangement / system as listed in the second column of Tab 2 and having a Biosafe Index, calculated in accordance with [4.1] greater than or equal to 40.

## 6 Novel features

### 6.1 General

#### 6.1.1 (15/6/2020)

For the assignment of the notation, the Society may consider arrangements, systems and components and operative procedures not listed in Tab 2 based on novel principles and features on the basis of validated supporting information.

## 7 Systems and components

### 7.1 Statements for systems and components contributing to the BIOSAFE Index

#### 7.1.1 (15/6/2020)

When systems and components are recognized as being capable of improving the ship's infection resilience, the Society may issue, upon request of the applicant (manufacturer or responsible vendor), a statement relevant to properties of the system or component in respect of recognized standard or following validation test campaign.

The statement may be issued in accordance with applicable national or international standards or, in the absence of such standards, on the basis of the manufacturer's standards or specifications.

The compliance to the reference document is ascertained by means of:

- execution of tests; or
- review of test documentation issued by independent, qualified and recognized laboratory; or
- evidence of positive results during in-service operation; or
- any combination of the above criteria.

## SECTION 34 REMOTE

### 1 General

#### 1.1 Application

##### 1.1.1 (1/1/2023)

The additional class notation **REMOTE** is assigned, in accordance with Pt A, Ch 1, Sec 2, [6.14.50], to ships:

- provided with specific arrangements and qualified personnel on board in order to facilitate the Society to carry out remotely the eligible class surveys in Pt A, Ch 2, App 5, Tab 1;
- provided with electronic certificates.

The Society reserves the right, at its sole discretion, to either suspend or withdraw the Additional Class Notation in case of worsening of the ship's condition of maintenance or PSC performance, or change of Management Company, unavailability of the specific arrangements and certified personnel on board.

#### 1.2 Definitions

##### 1.2.1 (1/1/2023)

- Remote Survey: a process of verifying that a ship and its equipment are in compliance with the Rules where the verification is undertaken, or partially undertaken, without attendance of the Surveyor on board.

Note 1: Remote classification activities not requiring a survey, such as some administrative tasks, are not to be considered as remote surveys.

- Connectivity Kit: an electronic system which allows livestreaming videos to be taken in enclosed spaces (e.g. engine room, tanks, etc.) where internet connection is not available, as detailed in [2].

### 2 Requirements

#### 2.1 Devices for livestreaming

##### 2.1.1 (5/6/2020)

A portable device (smartphone, tablet, etc.) provided with wide angle functionality and high-quality optical lenses is to be available on board.

Closed type headphones with microphone, for proper communication during livestreaming, are also requested.

#### 2.2 Connectivity Kit

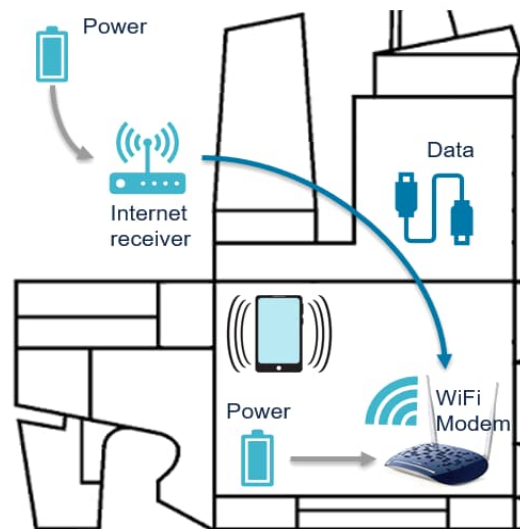
##### 2.2.1 (5/6/2020)

The ship is to be provided with a Connectivity Kit (see Fig 1) enabling the ship to have internet access also in enclosed spaces (ballast tanks, engine room, etc.).

The kit shall be composed of:

- an internet receiver, equipped with a sim card for data transfer
- a Wi-Fi modem
- a network cable of sufficient length to connect the two a.m. devices
- power packs to make the devices independent from the ship's electrical power supply.

Figure 1 (5/6/2020)



#### 2.3 Hazardous areas

##### 2.3.1 (1/1/2023)

In hazardous areas, all devices used, under the responsibility of the Master, for livestreaming or offline recordings and the Connectivity Kit are to be of an appropriately certified safe type.

#### 2.4 Training, qualification and certification of on-board personnel

##### 2.4.1 (1/1/2023)

The on-board personnel (ship's crew members) who take an active part in the remote survey and manage the devices for live streaming to take videos and pictures (even if offline) and the Connectivity Kit are to be in possession of the Certificate of Competency issued by the Society upon satisfactory completion of the specific e-learning course made available by the Society and aimed at providing the necessary operational information and skills.

#### 2.5 Electronic certificates

##### 2.5.1 (5/6/2020)

The class and statutory certificates issued to the ship by the Society are to be in electronic form.

### 3 Assignment of the additional class notation

#### 3.1

##### 3.1.1 (5/6/2020)

The additional class notation **REMOTE** is assigned upon:

- satisfactory evaluation by the Society of the requirements in [1.1] being complied with; and
- satisfactory verification on board by a Society's Surveyor of the requirements from [2.1] to [2.5] being complied with.

**SECTION 35****NH3 FUELLED READY (X1, X2, X3...)****1 General****1.1 Application****1.1.1 (1/5/2021)**

The additional class notation **NH3 FUELLED READY (X1, X2, X3...)** is assigned, in accordance with Pt A, Ch 1, Sec 2, [6.14.53], to ships fulfilling the requirements of this section.

A Statement of Compliance may be issued to ships not classed with the Society, fulfilling the requirements of this section.

**2 Assignment criteria****2.1****2.1.1 (1/5/2021)**

The additional class notation **NH3 FUELLED READY (X1, X2, X3...)** is assigned:

- a) to new buildings that are in accordance with the Tasneef Rules in force at the date when the contract for construction between the Owner and the shipbuilder is signed;
- b) to existing ships that are in accordance with the Tasneef Rules in force at the date of request of notation assignment.

having the following characteristics:

- Design (X1); and
- One of the following:
  - Structure (X2);
  - Tank (X3);
  - Piping (X4);
  - Users (X5).

The notation characteristics (**X1, X2, X3...**) are defined in Sec 24, Tab 1.

Irrespective of previous assignment of the **NH3 FUELLED READY** notation, when the ship will be converted to use NH3 as fuel, approval for compliance with Tasneef requirements in force at the time of conversion, followed by testing and commissioning under survey, will be required.

**Table 1 : Description of the notation characteristics (1/5/2021)**

X <sub>i</sub>	Characteristic	Description
1	Design	The complete design of the ship with NH3 fuelled system is found to be in compliance with the rules applicable to new buildings, including those in Pt C, Ch 1, App 13
2	Structure	Structural reinforcements to support the fuel containment system (NH3 fuel tank(s)) are installed and materials to support the relevant temperatures are used.
3	Tank	NH3 storage tank, tank master isolation valve, fuel venting arrangements and, where applicable, the fuel storage hold space, structural fire protection and ventilation arrangements for under deck tank locations are built under survey and installed in accordance with approved drawings and certified fit for NH3 fuel operations.
4	Piping	All piping equipment associated with the NH3 fuelled system, e.g. pipes, pumps, valves, etc. including all bunkering arrangements and associated access arrangements including structural fire protection as applicable, are built and installed in accordance with approved drawings and certified fit for NH3 fuel operations

$X_i$	Characteristic	Description
5	Users	<p>Engineering systems are installed in accordance with approved drawings and certified fit for using NH<sub>3</sub> as fuel or ready to be retrofitted:</p> <ul style="list-style-type: none"> <li>• ME<sub>NH<sub>3r</sub></sub>: Main engine(s) installed can be converted to using NH<sub>3</sub> as fuel;</li> <li>• ME<sub>NH<sub>3</sub></sub>: Main engine(s) installed are suitable to use NH<sub>3</sub> as fuel;</li> <li>• AE<sub>NH<sub>3r</sub></sub>: Auxiliary engines installed can be converted to using NH<sub>3</sub> as fuel (see Note 1);</li> <li>• AE<sub>NH<sub>3</sub></sub>: Auxiliary engines installed are suitable to use NH<sub>3</sub> as fuel (see Note 1);</li> <li>• B<sub>NH<sub>3r</sub></sub>: Boilers installed can be converted to using NH<sub>3</sub> as fuel;</li> <li>• B<sub>NH<sub>3</sub></sub>: Boilers installed can be operated on NH<sub>3</sub> as fuel.</li> </ul>
<p>Note 1: The capacity of the converted auxiliary engines is to be sufficient for the ship power balance.</p> <p>Examples:</p> <ul style="list-style-type: none"> <li>• NH<sub>3</sub> FUELLED READY (Design, Users(ME<sub>NH<sub>3r</sub></sub>)) means that the future NH<sub>3</sub> fuelled design has been examined and found in compliance with the applicable rules and the ship main engine is of a type that can be converted to use NH<sub>3</sub> as fuel;</li> <li>• NH<sub>3</sub> FUELLED READY (Design, Structure, Users(ME<sub>NH<sub>3r</sub></sub>, AE<sub>NH<sub>3r</sub></sub>)) means that the future NH<sub>3</sub> fuelled design has been examined and found in compliance with the applicable rules, the ship is constructed with the necessary structural reinforcement and suitable materials around the NH<sub>3</sub> fuel tank(s), and the main and auxiliary engines are of types that can be converted to dual fuel engines.</li> </ul>		

### 3 Documents to be submitted

deemed necessary for the evaluation of the systems and components.

#### 3.1 Documentation requirements for characteristic "Design"

#### 3.2 Documentation requirements for characteristics "Structure", "Tank", "Piping", "Users"

##### 3.1.1 (1/5/2021)

The list of plans and documents to be submitted is given in Sec 24, Tab 2.

The documentation is to be marked "NH<sub>3</sub> FUELLED ready" in each drawing title.

The Society reserves the right to require additional documents in the case of non-conventional design or if it is

##### 3.2.1 (1/5/2021)

The design, applicable to the assigned characteristic, is to be submitted and approved for compliance with the applicable requirements of Pt C, Ch 1, App 13.

**Table 2 : Documents to be submitted (1/5/2021)**

Item n°	Documentation	Additional description
1	General arrangement	Including NH <sub>3</sub> tank location with distances from ship side, adjacent spaces, bunkering station location, pipe routing, engine room arrangement and location of any other spaces containing NH <sub>3</sub> equipment. Location of entrances (air locks as relevant) for spaces with NH <sub>3</sub> equipment are also to be shown.
2	Engine room arrangement	Only if not included in the general arrangement.
3	Design philosophy/description	Including information on the NH <sub>3</sub> storage, machinery configuration, engine room arrangements, fuel arrangements, shut down philosophy, redundancy considerations etc.
4	Hazardous zones drawing	General arrangement plan with the indication of the hazardous area classification according to IEC 60092-502, but including the additional areas to be regarded as hazardous in respect of toxic or oxygen depleted atmosphere.
5	Ventilation system	For NH <sub>3</sub> equipment spaces, including ventilation capacity, location of inlets and outlets, segregation from other ventilation systems.
6	Tank drawings and arrangement	Including arrangement of tank connection space and pump rooms/compressor rooms where relevant. The NH <sub>3</sub> tank design drawings are preferably to contain sufficient detail to allow for structural strength and thermal exposure calculations for surrounding structure.
7	Structural strength calculation for the NH <sub>3</sub> fuel tank location	

Item n°	Documentation	Additional description
8	Temperature calculations around the NH3 fuel tanks	In case the NH3 is not carried in a fully-pressurized status at ambient conditions
9	P&ID for NH3 bunkering and NH3 fuel systems	Including details for double piping/ducts and arrangement/ location of vent mast/vent outlet(s) for pressure relief valves and purging.
10	Inert gas system	
11	Bilge system	Where fitted in spaces containing NH3 equipment
12	Stability calculations with NH3 tank(s) included	
13	Bunkering station arrangement	
14	Risk assessment report	

## SECTION 36

## SUSTAINABLE SHIP

### 1 General

#### 1.1 Application

##### 1.1.1 (1/1/2023)

The additional class notation **SUSTAINABLE SHIP** is assigned, in accordance with Pt A, Ch 1, Sec 2, [6.14.54], to ships complying with the criteria in [5], having regard to:

- a) design and provision of systems, components and procedural means to control and prevent the emission of polluting substances into the sea, the air and, more in general, the environment (reference is made to **GREEN PLUS** additional class notation)
- b) underwater noise limitation (reference is made to **DOLPHIN** additional class notations)
- c) noise and vibration limitation on board (reference is made to **COMF-NOISE** and **COMF-VIB** additional class notations)
- d) compliance with **NOISE-PORT-OUT(X)** or **NOISE-PORT-IN(X)** additional class notations
- e) compliance with **MLCDESIGN** additional class notation
- f) compliance with **BIOSAFE SHIP** additional class notation
- g) achievement of EEDI and EEXI values 40% lower than those in Phase 0 EEDI reference lines (see Note 1) in MARPOL Annex VI, according to the 2030 target in Initial IMO strategy on reduction of GHG emissions from ships (Res. MEPC.304(72)).

Note 1: For ro-ro cargo ships and ro-ro passenger ships, reference is made to Phase 2 EEDI reference lines.

A Certificate of Compliance may be issued to ships not classed with the Society, fulfilling the requirements of this section.

### 2 Definitions

#### 2.1

##### 2.1.1 (1/1/2023)

Definitions are those given in:

- Ch 6, Sec 1 (**COMF-NOISE** additional class notation)
- Ch 6, Sec 2 (**COMF-VIB** additional class notation)
- Ch 6, Sec 4 (**NOISE-PORT-OUT(X)** and **NOISE-PORT-IN(X)** additional class notations)
- Ch 7, Sec 1 (**GREEN PLUS** additional class notation)
- Sec 13 (**MLCDESIGN** additional class notation)
- Sec 25 (**DOLPHIN** additional class notations)
- Sec 33 (**BIOSAFE SHIP** additional class notation)
- MARPOL Annex VI.

### 3 Documents to be submitted

#### 3.1

##### 3.1.1 (1/1/2023)

The list of plans and documents to be submitted is given in the relevant paragraphs of:

- Ch 6, Sec 1 (**COMF-NOISE** additional class notation)
- Ch 6, Sec 2 (**COMF-VIB** additional class notation)
- Ch 6, Sec 4 (**NOISE-PORT-OUT(X)** and **NOISE-PORT-IN(X)** additional class notations)
- Ch 7, Sec 1 (**GREEN PLUS** additional class notation)
- Sec 13 (**MLCDESIGN** additional class notation)
- Sec 25 (**DOLPHIN** additional class notations)
- Sec 33 (**BIOSAFE SHIP** additional class notation).

The Society reserves the right to request the submission of additional documents in the case of non-conventional design or when it is deemed necessary for the evaluation of the systems and components.

### 4 Sustainable index calculation

#### 4.1

##### 4.1.1 (1/7/2021)

The sustainable index is obtained by adding up the values of the contributions for each criteria the ship complies with, according to Tab 1.

### 5 Assignment criteria

#### 5.1

##### 5.1.1 (1/7/2023)

The **SUSTAINABLE SHIP** notation is assigned to ships complying with the requirements for assignment of at least two of the criteria a) to g) specified in Tab 1. The relevant sustainable index is calculated in accordance with [4].

Examples:

- A ship in full compliance with the requirements of **GREEN PLUS**, **DOLPHIN**, **COMF-NOISE**, **COMF-VIB**, **NOISE-PORT-OUT(X)** or **NOISE-PORT-IN(X)**, **MLCDESIGN**, **BIOSAFE SHIP** additional class notations and having an EEXI value 40% lower than those in EEDI reference lines in MARPOL Annex VI is a **SUSTAINABLE SHIP** with sustainable index 100.
- A ship, having an environmental index, as defined in the **GREEN PLUS** requirements, equal to 63; a documented compliance to the contractual ship specification regarding noise or vibration levels; full compliance with the requirements of **MLCDESIGN** and

**BIOSAFE SHIP** additional class notations, is a **SUSTAINABLE SHIP** with sustainable index 20.

**Table 1 : Criteria for the assignment of SUSTAINABLE SHIP (1/7/2023)**

		Sustainable index
a) design and provision of systems, components and procedural means to control and prevent the emission of polluting substances into the sea, the air and, more in general, the environment (reference is made to <b>GREEN PLUS</b> additional class notation)	60 < E.I. ≤ 80 <b>(1)</b>	5
	80 < E.I. ≤ 100 <b>(1)</b>	10
	E.I. > 100 <b>(1)</b>	20
b) underwater noise limitation (reference is made to <b>DOLPHIN</b> additional class notations)		20
c) ensuring comfort having regard to noise and vibration on board	Documented compliance regarding <b>noise or vibration</b> measurements with the contractual ship specification	5
	Documented compliance regarding <b>noise and vibration</b> measurements with the contractual ship specification	10
	Compliance with <b>COMF-NOISE</b> additional class notation	10
	Compliance with <b>COMF-VIB</b> additional class notation	10
d) compliance with <b>NOISE-PORT-OUT(X)</b> or <b>NOISE-PORT-IN(X)</b> additional class notations		10
e) compliance with <b>MLCDESIGN</b> additional class notation		5
f) compliance with <b>BIOSAFE SHIP</b> additional class notation		5
g) achievement of EEDI and EEXI values 40% lower than those in Phase 0 EEDI reference lines in MARPOL Annex VI <b>(2)</b>		20
<b>(1)</b> E.I. is the <b>GREEN PLUS</b> Environmental Index <b>(2)</b> For ro-ro cargo ships and ro-ro passenger ships, reference is made to Phase 2 EEDI reference lines		



# SECTION 37 MARITIME AUTONOMOUS SURFACE SHIPS (MASS)

## 1 General

### 1.1 Application

#### 1.1.1 (1/10/2021)

The additional class notations **MASS (Maritime Autonomous Surface Ship)** are assigned, in accordance to Pt A, Ch 1, Sec 2, [6.14.55], to ships complying with the requirements in this section.

#### 1.1.2 (1/10/2021)

A Certificate of Compliance may be issued to ships not classed with the Society, fulfilling the requirements of this section.

### 1.2 Scope and assignment criteria

#### 1.2.1 (1/10/2021)

The additional class notations MASS are assigned to ships in service and new ships which can operate - to a varying degree - independent of human interaction and comply with the requirements (excluding [2.3]) in Tasneef Guide for Maritime Autonomous Surface Ships (MASS), hereinafter named "GUI.35".

#### 1.2.2 (1/10/2021)

Such ships may use both traditional and MASS technology. The additional class notations MASS only apply to the latter, while for any other aspect of the ship, all relevant applicable rules are to be complied with.

The parts of the rules applicable to conventional ship operation that are not applicable for MASS technology are to be specified for the Society's acceptance for class items and Flag Administration's acceptance for statutory items.

#### 1.2.3 (1/10/2021)

Definitions are those given in:

- **MASS-ADS:** Ship with Automated processes and Decision Support: Seafarers are on board to operate and control shipboard systems and functions. Some operations may be automated and at times be unsupervised but with seafarers on board ready to take control.
- **MASS-RCM:** Remotely Controlled Manned ship: the ship is controlled and operated from another location. Seafarers are available on board to take control and to operate the shipboard systems and functions.
- **MASS-RCU:** Remotely Controlled Unmanned ship: the ship is controlled and operated from another location. There are no seafarers on board.
- **MASS-FAS:** Fully autonomous ship: the operating system of the ship can make decisions and determine actions by itself.

#### 1.2.4 (1/10/2021)

It should be noted that one ship can operate at different degrees of autonomy in different operative conditions. In such cases, the ship shall be assigned with more than one class notation MASS, each one relevant to a different degree of autonomy.

### 1.3 Documents to be submitted

#### 1.3.1 (1/10/2021)

The documents listed in Tab 1 are to be submitted to the Society by the Owner.

**Table 1 : Documents to be submitted (1/7/2021)**

No.	A/I	Document	Ref.
1	I	Concept of Operations (CONOPS)	GUI.35 para. 1.3.3
2	I	Operational Design Domain (ODD)	GUI.35 para. 1.3.4
3	I	Details on human role and location	GUI.35 para. 1.3.2
4	A	Documentation demonstrating the compliance with the applicable functional and performance requirements described in GUI.35 paragraphs 3 to 6	GUI.35 paragraphs 3 to 6
5	I	Reference rules and standards applicable for the fulfilment of the tasks intended to be carried out by MASS technology, with specific indication of the parts that are not applicable, or the application of which requires specific interpretation	GUI.35 para. 2.1
6	I	Risk assessment, including also cyber security risks	GUI.35 para.1.4
7	I	Test reports required in GUI.35 paragraphs 2.2, 3.6 and 4 to 6	GUI.35 paragraphs 2.2, 3.6 and 4 to 6
<b>(1)</b> A: to be submitted for approval I: to be submitted for information			

## SECTION 38

## H2 FUELLED READY (X1, X2, X3...)

### 1 General

#### 1.1 Application

##### 1.1.1 (1/10/2021)

The additional class notation **H2 FUELLED READY (X1, X2, X3...)** is assigned, in accordance with Pt A, Ch 1, Sec 2, [6.14.57], to ships fulfilling the requirements of this section.

A Statement of Compliance may be issued to ships not classed with the Society, fulfilling the requirements of this section.

### 2 Assignment criteria

#### 2.1

##### 2.1.1 (1/10/2021)

The additional class notation **H2 FUELLED READY (X1, X2, X3...)** is assigned:

- a) to new buildings that are in accordance with the Tasneef Rules in force at the date when the contract for con-

struction between the Owner and the shipbuilder is signed;

- b) to existing ships that are in accordance with the Tasneef Rules in force at the date of request of notation assignment

having the following characteristics:

- Design (X1); and
- One of the following:
  - Structure (X2);
  - Tank (X3);
  - Piping (X4);
  - Users (X5).

The notation characteristics (**X1, X2, X3...**) are defined in Tab 1.

Irrespective of previous assignment of the **H2 FUELLED READY** notation, when the ship will be converted to use hydrogen as fuel, approval for compliance with Tasneef requirements in force at the time of conversion, followed by testing and commissioning under survey, will be required.

**Table 1 : Description of the notation characteristics (1/10/2021)**

Xi	Characteristic	Description
1	Design	The complete design of the ship with hydrogen fuelled system is found to be in compliance with the rules applicable to new buildings, including those in Pt C, Ch 1, App 14.
2	Structure	Structural reinforcements to support the fuel containment system (hydrogen fuel tank(s)) are installed and materials to support the relevant temperatures are used.
3	Tank	Hydrogen storage tank, tank isolation valve, fuel venting arrangements and, where applicable, the fuel storage hold space, structural fire protection and ventilation arrangements for under deck tank locations are built under survey and installed in accordance with approved drawings and certified fit for hydrogen fuel operations.
4	Piping	All piping equipment associated with the hydrogen fuelled system, e.g. pipes, pumps, valves, etc. including all bunkering arrangements and associated access arrangements including structural fire protection as applicable, are built and installed in accordance with approved drawings and certified fit for hydrogen fuel operations.

Xi	Characteristic	Description
5	Users	<p>Engineering systems are installed in accordance with approved drawings and certified fit for using hydrogen as fuel or ready to be retrofitted:</p> <ul style="list-style-type: none"> <li>• ME<sub>H2r</sub>: Main engine(s) installed can be converted to using hydrogen as fuel;</li> <li>• ME<sub>H2</sub>: Main engine(s) installed are suitable to use hydrogen as fuel;</li> <li>• AE<sub>H2r</sub>: Auxiliary engines installed can be converted to using hydrogen as fuel (see Note 1);</li> <li>• AE<sub>H2</sub>: Auxiliary engines installed are suitable to use hydrogen as fuel (see Note 1);</li> <li>• B<sub>H2r</sub>: Boilers installed can be converted to using hydrogen as fuel;</li> <li>• B<sub>H2</sub>: Boilers installed can be operated on hydrogen as fuel.</li> </ul>
<p><b>Note 1:</b>The capacity of the converted auxiliary engines is to be sufficient for the ship power balance.</p> <p>Examples:</p> <ul style="list-style-type: none"> <li>• H2 FUELLED READY (Design, Users(ME<sub>H2r</sub>)) means that the future hydrogen fuelled design has been examined and found in compliance with the applicable rules and the ship main engine is of a type that can be converted to use hydrogen as fuel;</li> <li>• H2 FUELLED READY (Design, Structure, Users(ME<sub>H2r</sub>, AE<sub>H2r</sub>)) means that the future hydrogen fuelled design has been examined and found in compliance with the applicable rules, the ship is constructed with the necessary structural reinforcement and suitable materials around the hydrogen fuel tank(s), and the main and auxiliary engines are of types that can be converted to dual fuel engines.</li> </ul>		

### 3 Documents to be submitted

deemed necessary for the evaluation of the systems and components.

#### 3.1 Documentation requirements for characteristic "Design"

#### 3.2 Documentation requirements for characteristics "Structure", "Tank", "Piping", "Users"

##### 3.1.1 (1/10/2021)

The list of plans and documents to be submitted is given in Tab 2.

##### 3.2.1 (1/10/2021)

The documentation is to be marked "H2 FUELLED READY" in each drawing title.

The design, applicable to the assigned characteristic, is to be submitted and approved for compliance with the applicable requirements of Pt C, Ch 1, App 14.

The Society reserves the right to require additional documents in the case of non-conventional design or if it is

**Table 2 : Documents to be submitted (1/10/2021)**

Item n°	Documentation	Additional description
1	General arrangement	Including hydrogen tank location with distances from ship side, adjacent spaces, bunkering station location, pipe routing, engine room arrangement and location of any other spaces containing hydrogen equipment. Location of entrances (air locks as relevant) for spaces with hydrogen equipment are also to be shown.
2	Engine room arrangement	Only if not included in the general arrangement.
3	Design philosophy/ description	Including information on the hydrogen storage, machinery configuration, engine room arrangements, fuel arrangements, shut down philosophy, redundancy considerations, etc.
4	Hazardous zones drawing	General arrangement plan with the indication of the hazardous area classification according to IEC 60092-502, but including the additional areas to be regarded as hazardous in respect of oxygen depleted atmosphere.
5	Ventilation system	For hydrogen equipment spaces, including ventilation capacity, location of inlets and outlets, segregation from other ventilation systems.
6	Tank drawings and arrangement	Including arrangement of tank connection space and pump rooms/compressor rooms where relevant. The hydrogen tank design drawings are preferably to contain sufficient detail to allow for structural strength and thermal exposure calculations for surrounding structure.
7	Structural strength calculation for the hydrogen fuel tank location	

Item n°	Documentation	Additional description
8	Temperature calculations around the hydrogen fuel tanks	In case the hydrogen is not carried in a fully-pressurized status at ambient conditions.
9	P&ID for hydrogen bunkering and hydrogen fuel systems	Including details for double piping/ducts and arrangement/location of vent mast/vent outlet(s) for pressure relief valves and purging.
10	Inert gas system	
11	Bilge system	Where fitted in spaces containing hydrogen equipment.
12	Stability calculations with hydrogen tank(s) included	
13	Bunkering station arrangement	
14	Risk assessment report	

## SECTION 39

## METHYL/ETHYL ALCOHOL FUELLED READY (X1, X2, X3...)

## 1 General

## 1.1 Application

## 1.1.1 (1/1/2022)

The additional class notation **METHYL/ETHYL ALCOHOL FUELLED READY (X1, X2, X3...)** is assigned, in accordance with Pt A, Ch 1, Sec 2, [6.14.59], to ships fulfilling the requirements of this section.

A Statement of Compliance may be issued to ships not classed with the Society, fulfilling the requirements of this section.

## 2 Assignment criteria

## 2.1

## 2.1.1 (1/1/2022)

The additional class notation **METHYL/ETHYL ALCOHOL FUELLED READY (X1, X2, X3...)** is assigned:

- a) to new buildings that are in accordance with the Tasneef Rules in force at the date when the contract for

construction between the Owner and the shipbuilder is signed;

- b) to existing ships that are in accordance with the Tasneef Rules in force at the date of request of notation assignment

having the following characteristics:

- Design (X1); and
- One of the following:
  - Structure (X2);
  - Tank (X3);
  - Piping (X4);
  - Users (X5).

The notation characteristics (X1, X2, X3...) are defined in Tab 1.

Irrespective of previous assignment of the **METHYL/ETHYL ALCOHOL FUELLED READY** notation, when the ship will be converted to use methyl/ethyl alcohol as fuel, approval for compliance with Tasneef requirements in force at the time of conversion, followed by testing and commissioning under survey, will be required.

**Table 1 : Description of the notation characteristics (1/1/2022)**

Xi	Characteristic	Description
1	Design	The complete design of the ship with methyl/ethyl alcohol fuelled system is found to be in compliance with the rules applicable to new buildings, including those in Pt C, Ch 1, App 15.
2	Structure	Structural reinforcements to support the independent methyl/ethyl alcohol fuel tank(s) are installed
3	Tank	Methyl/ethyl alcohol storage and service tank (including cofferdam), tank isolation valve, fuel venting arrangements and, where applicable, the fuel storage hold space, structural fire protection and ventilation arrangements for under deck tank locations are built under survey and installed in accordance with approved drawings and certified fit for methyl/ethyl alcohol fuel operations

**Note 1:** The capacity of the converted auxiliary engines is to be sufficient for the ship power balance.

Examples:

- METHYL/ETHYL ALCOHOL FUELLED READY (Design, Users(ME<sub>ALCr</sub>)) means that the future methyl/ethyl alcohol fuelled design has been examined and found in compliance with the applicable rules and the ship main engine is of a type that can be converted to use methyl/ethyl alcohol as fuel;
- METHYL/ETHYL ALCOHOL FUELLED READY (Design, Structure, Users(ME<sub>ALCr</sub>, AE<sub>ALCr</sub>)) means that the future methyl/ethyl alcohol fuelled design has been examined and found in compliance with the applicable rules, the ship is constructed with the necessary structural reinforcement for methyl/ethyl alcohol fuel tank(s), and the main and auxiliary engines are of types that can be converted to dual fuel engines.

Xi	Characteristic	Description
4	Piping	All piping equipment associated with the methyl/ethyl alcohol fuelled system, e.g. pipes, pumps, valves, etc. including all bunkering, gas freeing and inerting arrangements and associated access arrangements including structural fire protection as applicable, are built and installed in accordance with approved drawings and certified fit for methyl/ethyl alcohol fuel operations
5	Users	Engineering systems are installed in accordance with approved drawings and certified fit for using methyl/ethyl alcohol as fuel or ready to be retrofitted: <ul style="list-style-type: none"> <li>• ME<sub>ALCr</sub>: Main engine(s) installed can be converted to using methyl/ethyl alcohol as fuel;</li> <li>• ME<sub>ALC</sub>: Main engine(s) installed are suitable to use methyl/ethyl alcohol as fuel;</li> <li>• AE<sub>ALCr</sub>: Auxiliary engines installed can be converted to using methyl/ethyl alcohol as fuel (see Note 1);</li> <li>• AE<sub>ALC</sub>: Auxiliary engines installed are suitable to use methyl/ethyl alcohol as fuel (see Note 1);</li> <li>• B<sub>ALCr</sub>: Boilers installed can be converted to using methyl/ethyl alcohol as fuel;</li> <li>• B<sub>ALC</sub>: Boilers installed can be operated on methyl/ethyl alcohol as fuel.</li> </ul>
<p><b>Note 1:</b> The capacity of the converted auxiliary engines is to be sufficient for the ship power balance.</p> <p>Examples:</p> <ul style="list-style-type: none"> <li>• METHYL/ETHYL ALCOHOL FUELLED READY (Design, Users(ME<sub>ALCr</sub>)) means that the future methyl/ethyl alcohol fuelled design has been examined and found in compliance with the applicable rules and the ship main engine is of a type that can be converted to use methyl/ethyl alcohol as fuel;</li> <li>• METHYL/ETHYL ALCOHOL FUELLED READY (Design, Structure, Users(ME<sub>ALCr</sub>, AE<sub>ALCr</sub>)) means that the future methyl/ethyl alcohol fuelled design has been examined and found in compliance with the applicable rules, the ship is constructed with the necessary structural reinforcement for methyl/ethyl alcohol fuel tank(s), and the main and auxiliary engines are of types that can be converted to dual fuel engines.</li> </ul>		

**3 Documents to be submitted**

deemed necessary for the evaluation of the systems and components.

**3.1 Documentation requirements for characteristic "Design"**

**3.2 Documentation requirements for characteristics "Structure", "Tank", "Piping", "Users"**

**3.1.1 (1/1/2022)**

The list of plans and documents to be submitted is given in Tab 2.

**3.2.1 (1/1/2022)**

The documentation is to be marked "METHYL/ETHYL ALCOHOL FUELLED READY" in each drawing title.

The design, applicable to the assigned characteristic, is to be submitted and approved for compliance with the applicable requirements of Pt C, Ch 1, App 15.

The Society reserves the right to require additional documents in the case of non-conventional design or if it is

**Table 2 : Documents to be submitted (1/1/2022)**

No.	A/I (1)	Document
1	I	Propulsion system general arrangement - Design philosophy including information on the machinery configuration, engine room arrangements, fuel arrangements, shutdown philosophy (if applicable), redundancy considerations etc.
2	I	Methyl/ethyl alcohol fuel system risk assessment
3	A	Methyl/ethyl alcohol fuel system arrangement plan - including: <ul style="list-style-type: none"> <li>• methyl/ethyl alcohol storage and service tanks</li> <li>• tank connection spaces and cofferdams</li> <li>• fuel storage hold spaces</li> <li>• fuel preparation rooms</li> <li>• bunkering stations and other shore connections</li> <li>• engines and other consumers, service and control station spaces</li> <li>• doors and openings to fuel preparation rooms and other hazardous areas</li> <li>• vent mast</li> </ul>
4	A	Methyl/ethyl alcohol fuel tank freeing and purging system piping diagram with connections to inerting, venting and ventilation systems

No.	A/I (1)	Document
5	A	Methyl/ethyl alcohol fuel piping system: Pipe routing sketch Piping diagram with supply lines, bunkering lines, vent lines, double wall pipes or ducts arrangement
6	A	Inerting system - Piping diagram in connection with methyl/ethyl alcohol fuel system
7	A	Hazardous area classification drawing, including air-lock location
8	A	Ventilation of methyl/ethyl alcohol fuel system spaces including capacity and location of fans and their motors - Ducting diagram
9	A	Fixed methyl/ethyl alcohol detection system arrangement plan
10	I	Documentation of alternative design, as applicable
<b>(1)</b> A = to be submitted for approval I = to be submitted for information		

## SECTION 40

## ENHANCED MAINTENANCE (EM)

### 1 General

#### 1.1 Application

##### 1.1.1 (1/1/2024)

The additional class notation **ENHANCED MAINTENANCE (EM)** is assigned, in accordance with Pt A, Ch 1, Sec 2, [6.14.60] to ships of 20 years old and above, already assigned with the additional service feature **ESP** and complying with the requirements of this Section.

##### 1.1.2 Scope (1/1/2024)

The additional class notation **EM** is assigned to ships subject to enhanced maintenance as follows:

- a structural three-dimensional analysis to the extent agreed with the Society is performed for the hull structures, as defined in Pt B, Ch 7, App 1 or Pt B, Ch 7, App 2 or Pt B, Ch 7, App 3, as applicable,
- a Planned Maintenance Scheme (PMS) approved by the Society is in place and is enhanced by a risk analysis of the essential systems, and
- periodical and corrective maintenance, as well as periodical and occasional surveys of hull structures and equipment are carried out according to approved procedures included in the Inspection and Maintenance Plan (IMP), together with audits at the Owner's office.

The implementation of the IMP is surveyed by the Society through:

- periodical audits carried out at the Owner's offices and surveys carried out on board by Tasneef Surveyors, according to the types of inspection schemes in [3.3], and
- examination of the data recorded by the Owner and made available to the Society.

##### 1.1.3 Safety management system (1/11/2022)

The IMP and the PMS required under the scope of the **EM** notation are to be part of the Safety Management System to be certified in compliance with the ISM Code.

#### 1.2 Conditions for the assignment and maintenance of the notation

##### 1.2.1 Assignment of the notation (1/1/2024)

The procedure for the assignment of the **EM** notation is the following:

- a request for the notation is to be sent to the Society signed by the Owner
- the documents, specified in [2], are to be submitted to the Society by the Interested Party
- the Society reviews the already approved PMS and the results of the risk analysis
- the Society reviews and approves the IMP, taking into account the results of the structural analysis, as well as the information concerning the ship database and history
- the Society carries out an initial survey on board and audit at Owner's office to verify the submitted and approved documentation.

##### 1.2.2 Maintenance of the notation (1/1/2024)

The maintenance of the **EM** notation is based on the following surveys and checks, whose scope and periodicity are specified in [6], to be carried out by the Society:

- annual audits at the Owner's offices (see [6.1])
- annual shipboard surveys (see [6.2])
- class renewal surveys (see [6.4]).

### 2 Documentation to be submitted

#### 2.1 Plans and documents to be submitted for hull structures

##### 2.1.1 Structural analysis (1/1/2024)

The plans and documents necessary to support and/or perform the structural analysis covering hull structures are those listed in Tab 1.

However, depending on the service and specific features of the ship, the Society reserves the right to request additional or different plans and documents from those in Tab 1.

**Table 1 : Existing ships - Plans and documents to be submitted to perform the structural analysis (1/11/2022)**

i	Plans and documents
1	Midship section and Loading Manual
2	Transverse sections
3	Shell expansion
4	Longitudinal sections and decks
5	Double bottom
6	Pillar arrangements
7	Framing plan
8	Deep tank and ballast tank bulkheads



i	Plans and documents
9	Watertight subdivision bulkheads
10	Watertight tunnels
11	Wash bulkheads
12	Fore part structure
13	Aft part structure
14	Last thickness measurement report

### 2.1.2 Coatings (1/11/2022)

The following information on coatings is to be submitted:

- list of all structural items which are effectively coated
- characteristics of the coating system.

### 2.1.3 Cathodic protection (1/11/2022)

The following information on sacrificial anodes is to be submitted:

- localization of anodes in spaces, on bottom plating and sea chests
- dimensions and weight of anodes in new condition.

## 2.2 Hot spot map

### 2.2.1 (1/11/2022)

The items to be included in the hot spot map are, in general, the following:

- items (such as a plating panels, ordinary stiffeners or primary supporting members) for which the structural analysis carried out at the design stage showed that the ratio between the applied loads and the allowable limits exceeded 0,975
- items identified as "hot spot item" during the structural reassessment, according to Ch 1, App 2
- structural details subjected to fatigue, based on the list defined in Pt B, Ch 12, App 1
- other items, depending on the results of the structural analyses and/or on experience.

### 2.2.2 (1/1/2024)

The hot spot map is to also indicate the survey frequency.

## 2.3 Inspection and Maintenance Plan (IMP)

### 2.3.1 (1/1/2024)

The IMP is to be based on the ship's history and on the results of the structural analyses including the hot spot map.

The IMP is to include:

- the list of areas, spaces and hull equipment to be subjected to inspection
- the periodicity of inspections

- the elements to be assessed at annual and renewal surveys for the purpose of the **EM** notation, during the inspection for each area or space, as applicable:
  - coating
  - anodes
  - thicknesses
  - pitting
  - fractures
  - deformations
- the elements to be assessed during the inspection of hull equipment.

### 2.3.2 (1/1/2024)

As regards the IMP plan, the following information is to be given:

- maintenance scope
- maintenance type (inspection, reconditioning)
- maintenance frequency (periodicity value unit is to be clearly specified, i.e. hours, week, month, year)
- place of maintenance (port, sea, etc.)
- manufacturer's maintenance and repair specifications, as applicable
- procedures contemplated for repairs or renewal of structure or equipment.

## 2.4 Plans and documents to be submitted for machinery

### 2.4.1 Plans, documents and specifications (1/1/2024)

The following plans and documents are necessary to assign the **EM** notation:

- the risk analysis report, including the assumptions, considerations, risk models etc. that have brought to the resulting list of critical machinery/equipment of the selected systems, for the approval of the enhanced PMS
- the risk analysis report for the spare parts management applicable to those items considered critical, taking into account their location and availability for replacement
- the maintenance plan of machinery / equipment of the selected systems.

The documents are to be supplemented with the Manufacturer's specifications, including the list of relevant equipment and accessories and instructions for their use, as required.

The Society may request additional documents or information, when needed.

## 3 Inspection and Maintenance Plan (IMP)

### 3.1 Minimum requirements

#### 3.1.1 (1/11/2022)

The minimum requirements on the scope of the IMP, the periodicity of inspections, the extent of inspection and maintenance to be scheduled for each area, space or equipment concerned, and the minimum content of the

report to be submitted to the Society after the inspection are given hereafter.

**3.1.2 (1/11/2022)**

At the Owner's request, the scope and periodicity may be other than those specified below, provided that this is agreed with the Society.

**3.1.3 (1/1/2024)**

The IMP-based surveys performed at periodical intervals does not prevent the Owner from carrying out occasional inspections and maintenance as a result of an unexpected failure or event (such as damage resulting from heavy weather or cargo loading/unloading operation) which may affect the hull or hull equipment condition.

Interested parties are also reminded that any damage to the ship which may affect the class is to be reported to the Society.

The IMP is to be kept duly updated for any changes on board and findings during surveys.

**3.2 General scope of IMP**

**3.2.1 (1/11/2022)**

The IMP is to cover at least the following areas/items:

- deck area structure
- access hatches
- deck fittings
- steering gear
- superstructures
- shell plating
- ballast tanks, including peaks,
- cargo tanks and spaces
- other accessible spaces
- rudders
- sea connections and overboard discharges
- sea chests
- propellers
- further machinery/electrical items
- fire protection items

**3.3 Periodicity of inspections**

**3.3.1 (1/1/2024)**

Inspections schedule plan is to be arranged and finalized for each vessel taking into account the Type 1 to Type 3 inspection schemes in [3.3.2] to [3.3.4].

The IMP inspections performed at periodical intervals by the Society does not prevent Owner from carrying out occasional inspections and maintenance according to the instructions specified in the IMP, or unexpected failure or event (such as damage resulting from heavy weather or cargo loading/unloading) which may affect the ship or ship equipment condition.

**3.3.2 Type 1 (1/1/2024)**

The following areas/items are to be inspected at each annual EM survey:

- deck area structure
- welding seams between stainless steel and normal carbon steel
- shell plating above waterline
- access hatches
- deck equipment
- superstructures
- ballast tanks, including peaks
- other accessible spaces
- sea connections and overboard discharges.

**3.3.3 Type 2 (1/1/2024)**

The following areas/items are to be inspected at each intermediate EM survey:

- bunker and double bottom fuel oil tanks
- fresh-water tanks
- shell plating
- cargo tanks
- rudders
- propellers
- bottom plating
- sea chests and anodes.

**3.3.4 Type 3 (1/1/2024)**

The areas/items listed in [3.3.2] and [3.3.3] are to be inspected at each renewal EM survey.

**3.4 Extent of inspections**

**3.4.1 Deck area structure (1/11/2022)**

The deck plating, structure over deck and access hatch coamings, as applicable are to be visually examined for assessment of the coating, and detection of fractures, deformations and corrosion.

When structural defects affecting the class (such as fractures or deformations) are found, the Society is to be called for occasional survey attendance. If such structural defects are repetitive in similar areas of the deck, a program of additional close-up surveys may be planned at the Society's discretion for the next inspections.

In other cases, such as coating found in poor condition, repairs or renewal are to be dealt with, or a program of maintenance is to be set in agreement with the Society, at a suitable time, but at the latest at the next intermediate or class renewal survey, whichever comes first.

**3.4.2 Small hatches (1/11/2022)**

Access hatches are to be visually examined, in particular tightness devices, locking arrangements and coating condition, as well as signs of corrosion.

Any defective tightness device or securing/locking arrangement is to be dealt with.

**3.4.3 Deck fittings (1/11/2022)**

The inspection of deck fittings is to cover at least the following items:

- Piping on deck  
A visual examination of piping is to be carried out, with particular attention to coating, external corrosion, tightness of pipes and joints (examination under pressure), valves and piping supports. Operation of valves is to be checked.  
Any defective tightness, supporting device or valve is to be dealt with.
- Vent system  
A visual examination of the vent system is to be carried out. Dismantling is to be carried out as necessary for checking the condition of closure (flaps, balls) and clamping devices and of screens.  
Any defective item is to be dealt with.
- Ladders, guard rails, bulwarks, walkways  
A visual examination is to be carried out with attention to the coating condition (as applicable), corrosion, deformation or missing elements.  
Any defective item is to be dealt with.
- Anchoring and mooring equipment  
A visual examination of the windlass, winches, capstans, anchor and visible part of the anchor chain is to be carried out. A working test is to be carried out by lowering a sufficient length of chain on each side and the chain lengths thus ranged out are to be examined (shackles, studs, wastage).  
Any defective item is to be dealt with. For replacement of chains or anchors, the Society is to be requested for attendance.  
The manufacturer's maintenance requirements, if any, are to be complied with.
- Other deck fittings  
Other deck fittings are to be visually examined and dealt with under the same principles as those detailed in the items above according to the type of fitting.

#### 3.4.4 Steering gear (1/11/2022)

The inspection of the installation is to cover:

- examination of the installation
- test with main and emergency systems
- changeover test of working rams.

#### 3.4.5 Superstructures (1/11/2022)

The structural part of superstructures is to be visually examined and checked under the same scope as that required for deck structure.

The closing devices (doors, windows, ventilation system, skylights) are to be visually examined with attention to tightness devices and checked for their proper operation.

Any defective item is to be dealt with.

#### 3.4.6 Shell plating (1/11/2022)

The shell plating, sides and bottom, are to be visually examined for assessment of the coating, and detection of fractures, deformations and corrosion.

When structural defects affecting the class (such as fractures or deformations) are found, the Society is to be called for occasional survey attendance. If such structural defects are

repetitive in similar areas of the shell plating, a program of additional close-up surveys may be planned at the Society's discretion for the next inspections.

In other cases, such as coating found in poor condition, repairs or renewal are to be dealt with, or a program of maintenance is to be set in agreement with the Society, at a suitable time, but at the latest at the next intermediate or class renewal survey, whichever comes first.

#### 3.4.7 Ballast tanks (1/11/2022)

Ballast tanks, including peaks, are to be overall surveyed with regards to:

- structural condition (fractures, deformations, corrosion)
- condition of coating and anodes, if any
- fittings such as piping, valves.

A program of close-up survey may also be required, depending on the results of the structural analyses and the hot spot map.

When structural defects affecting the class are found, the Society is to be called for occasional survey attendance. If such structural defects (such as fractures or deformations) are repetitive in similar structures in the same ballast tanks or in other ballast tanks, a program of additional close-up survey may be planned at the Society's discretion for the next inspections.

In other cases, such as coating found in poor condition or anodes depleted, repairs or renewal are to be dealt with, or a program of maintenance is to be set in agreement with the Society, at a suitable time, but at the latest at the next intermediate or class renewal survey, whichever comes first.

#### 3.4.8 Cargo tanks (1/11/2022)

Cargo tanks are to be overall surveyed with regards to:

- structural condition (fractures, deformations, corrosion)
- condition of coating and anodes, if any
- fittings such as piping, valves.

A program of close-up survey may also be required, depending on the results of the structural analyses and the hot spot map.

When structural defects affecting the class are found, the Society is to be called for occasional survey attendance. If such structural defects (such as fractures or deformations) are repetitive in similar structures in the same ballast tanks or in other ballast tanks, a program of additional close-up survey may be planned at the Society's discretion for the next inspections.

In other cases, such as coating found in poor condition or anodes depleted, repairs or renewal are to be dealt with, or a program of maintenance is to be set in agreement with the Society, at a suitable time, but at the latest at the next intermediate or class renewal survey, whichever comes first.

#### 3.4.9 Other accessible spaces (1/11/2022)

Other spaces accessible during normal operation of the ship or port operations, such as cofferdams, void spaces, pipe tunnels and machinery spaces are to be examined and dealt

with under the same scope as that required for dry cargo holds and spaces.

Consideration is also to be given to the cleanliness of spaces where machinery and/or other equivalent equipment exist which may give rise to leakage of oil, fuel water or other leakage (such as main and auxiliary machinery spaces, cargo pump rooms, cargo compressor rooms, dredging machinery spaces, steering gear space).

#### **3.4.10 Rudder(s) (1/11/2022)**

A visual examination of rudder blade(s) is to be carried out to detect fractures, deformations and corrosion. Plugs, if any, have to be removed for verification of tightness of the rudder blade(s). Thickness measurements of plating are to be carried out in case of doubt. Access doors to pintles (if any) have to be removed. Condition of pintle(s) has to be verified. Clearances have to be taken.

Condition of connection with rudder stock is to be verified.

Tightening of both pintles and connecting bolts is to be checked.

#### **3.4.11 Sea connections and overboard discharges (1/11/2022)**

A visual external examination of sea inlets, outlet corresponding valves and piping is to be carried out in order to check tightness. An operation test of the valves and maneuvering devices is to be performed.

Any defective tightness and/or operability is to be dealt with.

#### **3.4.12 Sea chests (1/11/2022)**

Sea chests have to be examined with regards to:

- structural condition (fractures, deformations, corrosion)
- condition of cleanliness, coating and anodes
- visual examination of accessible part of piping or valve.

#### **3.4.13 Propellers (1/11/2022)**

A visual examination of propeller blades, propeller boss and propeller cap is to be carried out as regards fractures, deformations and corrosion. For variable pitch propellers, absence of leakage at the connection between the blades and the hub is to be also ascertained.

Absence of leakage of the aft tail shaft sealing arrangement is to be ascertained.

#### **3.4.14 Bunker and fuel oil tanks, fresh-water tanks (1/11/2022)**

Bunker and fuel oil tanks are to be overall surveyed with regards to:

- structural condition (fractures, deformations, corrosion)
- condition of coating and anodes, if any
- fittings such as piping, valves.

A program of close-up survey may also be required, depending on the results of the structural analyses and the hot spot map.

When structural defects affecting the class are found, the Society is to be called for occasional survey attendance. If such structural defects (such as fractures or deformations) are repetitive in similar structures in the same bunker/double bottom fuel oil tanks or in other

bunker/double bottom fuel oil tanks, a program of additional close-up survey may be planned at the Society's discretion for the next inspections.

In other cases, such as coating found in poor condition or anodes depleted, repairs or renewal are to be dealt with, or a program of maintenance is to be set in agreement with the Society, at a suitable time, but at the latest at the next intermediate or class renewal survey, whichever comes first.

### **3.5 Changes to Inspection and Maintenance Plan**

#### **3.5.1 (1/11/2022)**

Changes to ship operation, review of the inspection and maintenance reports, possible subsequent changes to the hot spot map and corrosion rates different than those expected may show that the extent of the maintenance performed needs to be adjusted to improve its efficiency.

Where more defects are found than would be expected, it may be necessary to increase the extent and/or the frequency of the maintenance program. Alternatively, the extent and/or the frequency of the maintenance may be reduced subject to documented justification.

## **4 Acceptance criteria**

### **4.1 Coating assessment**

#### **4.1.1 Criteria (1/1/2024)**

The acceptance criteria for the coating condition of each coated space is that the coating is to be in GOOD condition (i.e. with only minor spot rusting).

Where acceptance criteria are not fulfilled, coating is to be repaired.

#### **4.1.2 Repairs (1/11/2022)**

The procedures for repairs of coatings are to follow the coating manufacturer's specification for repairs, under the Owner's responsibility.

### **4.2 Sacrificial anode condition**

#### **4.2.1 Criteria (1/1/2024)**

The acceptance criteria for sacrificial anodes in each coated space fitted with anodes is that the loss in weight is to be less than 25%.

Where acceptance criteria are not fulfilled, sacrificial anodes are to be renewed.

### **4.3 Thickness measurements**

#### **4.3.1 General (1/11/2022)**

The acceptance criteria for measured thicknesses are indicated in:

- Ch 1, App 1 for isolated areas of items (for example a localized area of a plate)
- Ch 1, App 2 for items (for example a plating panel or an ordinary stiffener)
- Ch 1, App 3 for zones (for example the bottom zone).

When the acceptance criteria are not fulfilled, actions according to [4.3.2] to [4.3.4] are to be taken.

Specific considerations are given to stainless steel structures and the effects of passivation.

#### 4.3.2 Isolated area (1/11/2022)

The thickness diminution of an isolated area of an item is the localized diminution of the thickness of that item such as, for example, the grooving of a plate or a web or a local severe corrosion. It is expressed as a percentage of the relevant as built thickness.

It is not to be confused with pitting (see [4.4]).

If the criteria of acceptable diminution are not fulfilled for an isolated area, then this isolated area is to be repaired or replaced. In any case, the criteria of thickness diminution are to be considered for the corresponding item (see [4.3.3]).

#### 4.3.3 Item (1/11/2022)

For each item, thicknesses are measured at several points and the average value of these thicknesses is to satisfy the acceptance criteria for the relevant item.

If the criteria of measured thicknesses are not fulfilled for an item, then this item is to be repaired or replaced. Where the criteria are fulfilled, but substantial corrosion as defined in Pt A, Ch 2, Sec 2, [2.2.9] is found, the IMP is to be adjusted to increase the frequency and/or extent of the maintenance program. In any case, for the items which contribute to the hull girder longitudinal strength, the criteria in [4.3.4] are to be considered.

#### 4.3.4 Zone (1/11/2022)

For consideration of the hull girder longitudinal strength, the transverse section of the ship is divided into three zones:

- deck zone
- neutral axis zone
- bottom zone.

The sectional area diminution of a zone, expressed as a percentage of the relevant as built sectional area, is to fulfil the criteria of acceptable diminution for that zone.

If the criteria of acceptable diminution are not fulfilled for a zone, then some items belonging to that zone are to be replaced (in principle, those which are most worn) in order to obtain after their replacement an increased sectional area of the zone fulfilling the relevant criteria.

### 4.4 Pitting

#### 4.4.1 Pitting intensity (1/11/2022)

The pitting intensity is defined by the percentage of area affected by pitting.

The diagrams in Ch 1, App 4 are to be used to identify the percentage of area affected by pitting and thus the pitting intensity.

#### 4.4.2 Acceptable wastage (1/11/2022)

The acceptable wastage for a localized pit (intensity  $\leq 3\%$ ) is 23% of the average residual thickness.

For areas having a pitting density of 50% or more, the acceptable wastage in pits is 13% of the average residual thickness.

For intermediate values (between localized pit and 50% of affected area), the acceptable wastage in pits is to be obtained by interpolation between 23% and 13% of the average residual thicknesses (see Tab 2).

#### 4.4.3 Repairs (1/11/2022)

Application of filler material (plastic or epoxy compounds) is recommended as a mean for stopping/reducing the corrosion process, but this is not an acceptable repair for pitting exceeding the maximum permissible wastage limits.

Welding repairs may be accepted when performed in accordance with agreed procedures.

**Table 2 : Pitting intensity and corresponding acceptable wastage in pits (1/11/2022)**

Pitting intensity, in % (see Ch 1, App 4)	Acceptable wastage in pits, in percentage of the average residual thickness
$\leq 3$	23
5	22
10	21
15	20
20	19
25	18
30	17
40	15
50	13

### 4.5 Fractures

#### 4.5.1 General (1/11/2022)

Fractures are found, in general, at locations where stress concentrations occur.

In particular, fractures occur at the following locations:

- beginning or end of a run of welding
- rounded corners at the end of a stiffener
- traces of lifting fittings used during the construction of the ship
- weld anomalies
- welding at toes of brackets
- welding at cut-outs
- intersections of welds
- intermittent welding at the ends of each length of weld.

The structure under examination is to be cleaned and provided with adequate lighting and means of access to facilitate the detection of fractures.

If the initiation points of the fractures are not apparent, the structure on the other side of the plating is to be examined.

#### 4.5.2 Criteria (1/11/2022)

Where fractures are detected, the Society's Surveyor is always to be called for attendance.

## 5 Machinery items

### 5.1 Scope of IMP for machinery and systems

#### 5.1.1 General (1/11/2022)

The ship is to hold the PMS additional Class notation as per Pt A, Ch 2, Sec 2 and Ch 12, Sec 1.

A general examination of machinery and systems is to be carried out as part of the survey, paying attention to their overall condition, records of defects and functional tests.

In case a system to be surveyed (e.g. pumps) is fitted with equipment at quantity higher than the minimum required by the Rules, the total system equipment (e.g. all the pumps) will be considered for the notation application.

#### 5.1.2 Machinery (1/11/2022)

The survey of machinery is to include:

- a) general examination, including functional tests, of the main propulsion plant;
- b) internal inspection of items opened for maintenance:
  - assessment of items such as crankcase, scavenge spaces, piston rings, bearing clearance, cylinder heads of diesel engines;
  - bearing clearance and gearing condition of steam turbines;
  - internal examination including where possible water and gas spaces, and external examination of casing, burner equipment, blowers and safety valves of boilers and economisers;
- c) oil sample of oil systems such as gearing, crankcase, sterntube, to be taken for analysis.

#### 5.1.3 Electrical installations (1/11/2022)

The survey of electrical installations is to include:

- a) alternators functional tests under working conditions, both individually and during load sharing operations;
- b) visual inspection of the fittings and equipment of the main and emergency switchboards, section boards and subsidiary distribution boards;
- c) records of insulation-resistance tests performed on cables, switchgear, generators, motors, heaters and lighting fittings, spot tests to be witnessed;
- d) functional tests of the emergency source of power, associated circuits and equipment, including testing under working conditions.

#### 5.1.4 Auxiliary systems (1/11/2022)

The survey is to include the general examination including functional tests of auxiliary systems for propulsion, power generation, steering, fuel oil, lube oil, cooling water,

compressed air, steam, ventilation and accommodation services.

Each system is to be examined having regard to the general condition, leakages, supporting instrumentation, emergency arrangements, etc.

#### 5.1.5 Safety protection devices (1/11/2022)

The various safety protection devices fitted to protect machinery and machinery spaces (alarms, shutdowns, standby pumps cut-in, remote stops, remote closing valves, bilge alarms, fire flaps, etc.) are to be assessed in order to verify their correct operation.

#### 5.1.6 Other equipment (1/11/2022)

Anchor equipment, mooring systems, cargo gear and life-saving appliances are to be inspected and assessed by means of functional tests.

#### 5.1.7 Plant performance in terms of environmental impact (1/11/2022)

Performance tests and assessments are to be carried out for all equipment that has an impact on the environment such as fuel management, lube oil leakages, air emission, bilge cleanliness and oily water management.

#### 5.1.8 Cargo and ballast systems (1/11/2022)

The survey is to include the inspection and testing of cargo related equipment and systems, including:

- a) for tankers:
  - cargo pumps and piping with associated installations such as inert gas plant, washing systems, level indication/sounding systems, venting systems, ballast pumps and piping, and remote closing valves;
- b) for other types of ships:
  - cargo equipment and closing devices, bilge, ballast and ventilation systems.

A functional test is to be carried out while the ship is trading (during loading or unloading in the harbour).

#### 5.1.9 Winches and Windlasses (1/11/2022)

The survey of this equipment is to include:

- a) visual inspections of equipment foundations to confirm the absence of any deformation, excessive wear, corrosion or damage in general;
- b) visual examination of each equipment;
- c) functional tests of the equipment including prime mover, clutches, brakes, and other significant components on a case-by-case basis;
- d) braking systems are to be tested to check the rendering loads. A copy of the brake test results is to be retained on-board the ship.

#### 5.1.10 Anchoring equipment (1/11/2022)

The survey of this equipment is to include:

- a) visual examination;
- b) functional tests;
- c) braking systems are to be tested to check the rendering loads. A copy of the brake test results is to be retained on-board the ship.

### 5.1.11 Navigation equipment (1/11/2022)

Navigation equipment is to be tested under working conditions, and correct operation of navigation lights verified.

## 5.2 Performances

### 5.2.1 (1/11/2022)

The Owner, in agreement with the Society, may also select specific items on which to perform periodical verification of performances.

Minimum checks performed on internal combustion engines to ascertain their performance:

- Oil analysis
- Compression checks
- Specific consumption checks in a specified condition (reports of check carried out in specified conditions by the Company can be submitted to the Society for review)
- Injectors
- Engine power, through a minimum acceptable percentage of the original value
- Pressure test and maintenance of heat exchangers.

### 5.2.2 (1/11/2022)

Minimum features for cargo systems:

- Use of stainless steel in piping
- Periodical passivation of stainless steel piping every 3 years or less
- Procedures for periodical and occasional inspections of the following minimum components in cooperation with Makers:
  - Double valves
  - Gaskets
  - Washing and stripping system efficiency
  - Inert gas system efficiency.

## 5.3 Manufacturer's recommendations

### 5.3.1 (1/11/2022)

The EM notation is by no means to be considered a relaxation or a variation of the type and timing of maintenance recommended by the Manufacturer.

### 5.3.2 (1/11/2022)

Any possible change or optimization of the original maintenance scheme may be considered only after the expiry of the Manufacturer's warranty period, once that all involved machinery and equipment are set in service and the information relevant to the maintenance and performance of the various machinery and equipment is collected and elaborated, as necessary, in consultation with the Manufacturer, at the Owner's request.

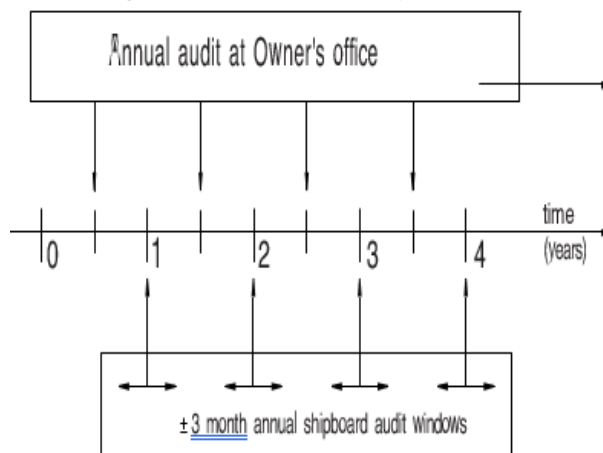
## 6 Maintenance of the notation

### 6.1 Annual audit at the Owner's offices

#### 6.1.1 (1/11/2022)

The audit is to be carried out annually preferably within the prescribed six-month window as shown in Fig 1.

Figure 1 : Audit periodicity (1/1/2024)



If two or more ships belonging to the same Owner are assigned the EM notation, this annual audit may be performed for all ships at the same time in a suitable period agreed between the Owner and the Society.

#### 6.1.2 (1/1/2024)

The Surveyor checks that the EM notation documents held at the Owner's offices are kept updated, in particular with the IMP.

The Society may call for:

- an occasional survey on board the ship by a Surveyor of the Society to be carried out as soon as possible
- corrective actions to be taken by the Owner in applying the IMP.

From the data collected during this audit and data received from the ship, a preliminary review is done. This review may lead to extending the scope of the audit and/or an occasional machinery survey on board the ship, specifically for machinery the performance of which is deteriorating. The audit includes the examination of:

- preventive maintenance records
- corrective maintenance records
- predictive maintenance records, i.e. planning records about outstanding inspections or other actions for the forthcoming period.

#### 6.1.3 (1/11/2022)

The annual audit at the Owner's offices performed before the commencement of the class renewal survey is to include the planning required for this survey (see [6.4.2]).

### 6.2 Annual EM survey

#### 6.2.1 (1/1/2024)

The annual EM survey is to be carried out concurrently with the annual survey.

**6.2.2** (1/1/2024)

During this survey, the Surveyor:

- verifies the consistency, implementation and management of the IMP by the Owner
- carries out additional inspections relevant to hull (structure and equipment), if deemed necessary
- carries out PMS surveys according to Ch 12, Sec 1, [4.2]
- verifies the items under the Type 1 inspection scheme in [3.3.2].

**6.3 Occasional EM survey**

**6.3.1** (1/1/2024)

Occasional surveys may be required when audits at the Owner's offices reveals that IMP or PMS has not been applied or working in the manner intended, or that particular equipment shows abnormal behaviour.

The Society is to be notified when an item is due to be repaired on a non-scheduled basis because of failure. The notification is to include the place, time and specification of the corrective action which has to be executed. The Society will decide whether to carry out an occasional on board survey.

The Society is to be notified of changes to the operation of the ship and/or modifications to machinery and/or equipment to, so that:

- a survey on board the ship may be carried out to verify the changes and modifications
- the effects of the changes and modifications may be taken into consideration, if deemed necessary, during the next risk analysis
- an immediate revision of the IMP is conducted, if deemed necessary.

The effects of any changes in relation to the IMP are monitored during the next annual shipboard audit.

**6.4 Renewal EM survey**

**6.4.1** (1/1/2024)

The survey for the renewal of the **EM** notation is to be carried out concurrently with the class renewal survey, taking into account the items under the Type 3 inspection scheme in [3.3.4].

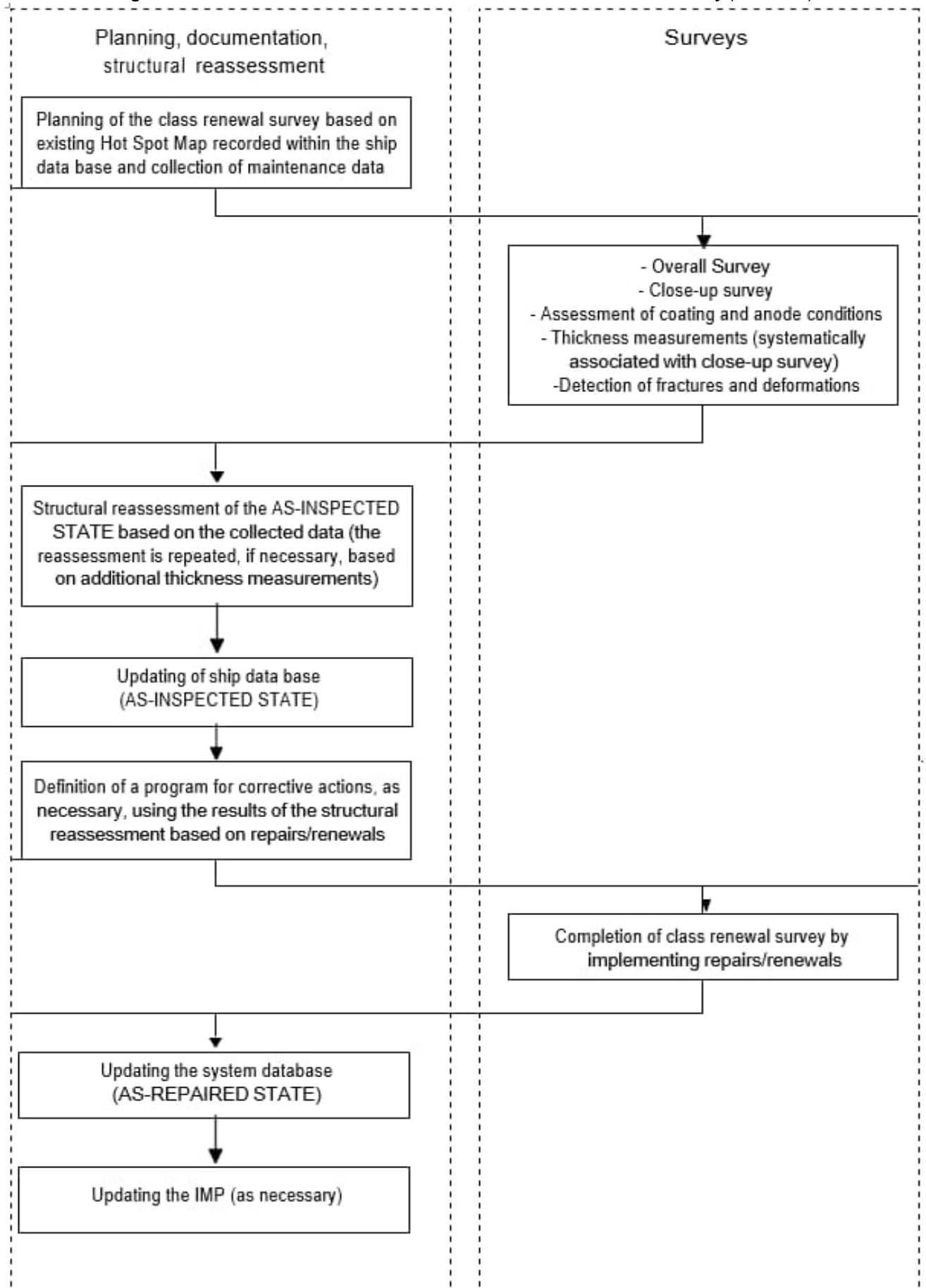
The documentation to be prepared, the surveys to be carried out and the structural reassessment to be done in connection with the class renewal survey are summarized in the flowchart shown in Fig 2.

**6.4.2** (1/1/2024)

The planning of the class renewal survey as required in Part A, Chapter 4 is to be used, taking into account possible presence of stainless steel and recommendation issued by manufacturers.



Figure 2 : Actions to be taken in connection with the Class Renewal Survey (1/11/2022)



#### 6.4.3 (1/1/2024)

In addition to the scope of the class renewal survey as required for the ship concerned, the following is to be carried out:

- an annual **EM** survey as detailed in [6.2]
- the assessment of the condition of coating and anodes
- the close-up survey and thickness measurements as required in the survey planning as a result of the previous structural assessment
- a specific survey for fatigue fracture detection in accordance with the planning as a result of the previous hot spot map
- a specific survey for assessing the effects of stainless steel structures passivation.

#### 6.4.4 (1/11/2022)

On the basis of the results of the surveys, thickness measurements and fatigue fracture detection carried out as indicated in [6.4.3], the "as-inspected state" of the ship is established. A structural reassessment of the "as-inspected state" is performed according to the criteria in Ch 1, App 2. This state may be progressively updated based on the results of additional inspections and/or thickness measurements required on the basis of the first "running" of the analysis.

Once the final "as-inspected state" is established, a program of corrective actions is defined, which may consist of:

- structural renewals
- repairs of structural defects (fractures, deformations, etc.)
- repairs/renewals of coating and/or anodes.

in order to ensure that the ship continues to comply with the acceptance criteria given in [4]. In addition, the IMP may be modified if needed.

#### 6.4.5 (1/11/2022)

The corrective actions are to be surveyed by a Surveyor of the Society. Subsequently a new "as-repaired state" of the ship is obtained, including an updated hot spot map.

#### 6.4.6 (1/11/2022)

The assignment of the **EM** notation implies that the class renewal surveys of machinery are carried out by applying the PMS described in Pt A, Ch 2, Sec 2 and Ch 12, Sec 1. The procedure of recognizing surveys carried out by the Chief Engineer, as indicated in Pt A, Ch 2, Sec 2 when CMS or PMS are adopted, is also to be applied.

### 6.5 Suspension and withdrawal of the notation

#### 6.5.1 (1/11/2022)

The maintenance of the **EM** notation is subject to the same principles as those for the maintenance of class: surveys are to be carried out by their limit dates and possible recommendations (related to the notation) are to be dealt with by their limit dates.

The suspension of class automatically causes the suspension of the **EM** notation.

#### 6.5.2 (1/1/2024)

Various events may lead either to imposition of a recommendation related to the **EM** notation or to suspension of the notation itself. Some cases are given below.

- The condition of the ship is below the minimum level required for class (e.g. scantling of hull structure below the corrosion margin). The action to be taken is either the immediate repair or the imposition of a recommendation for the class (if acceptable) and suspension of the **EM** notation. However, in cases where the recommendation is of a minor nature, the notation may not be suspended.
- The condition of the ship is below the minimum level for the **EM** notation, but still above the level for the class (e.g. the scantling of a hull structure is below the corrosion margin acceptable for the notation but is still above the corrosion margin). The action to be taken is either the immediate repair or the imposition of a recommendation for the **EM** notation (without recommendation for class).
- The IMP is not complied with (e.g. delays in performing the operations programmed according to the plan or the scope of inspection and/or maintenance not completely fulfilled), and/or the maintenance of the database is not fulfilled.

The action to be taken is:

- either the immediate compliance with the requirements or the imposition of a recommendation if the non-conformity is of a minor nature or is an exceptional occurrence
- or the suspension of the **EM** notation if the non-conformity is of a major nature or a recurrence.
- A defect or a deficiency is found in applying the IMP. The actions to be taken are the same as stated both for repair of structure/coating/equipment (first two cases above) and for the application of the IMP (third case above).
- An unexpected defect or deficiency is found or an accident occurs, i.e. not as a result of lack of maintenance or failure in the application of the IMP. The actions to be taken are the same as stated for repair of structure/coating/equipment (first two cases above).
- The condition of the machinery installations (i.e. for each system, all its equipment will be considered, see also [5.1.1]) is below the minimum level required for class. The action to be taken is either the immediate repair or the imposition of a recommendation for class (if acceptable) and suspension of the **EM** notation. However, in cases where the recommendation is of a minor nature, the notation may not be suspended.
- The spare parts availability is outside the risk analysis carried out.
- The PMS is not complied with (e.g. delays in performing the operations scheduled according to the plan or the scope of inspection and/or maintenance is not completely fulfilled), and/or the maintenance of the database is not fulfilled.

The action to be taken is either:

- the immediate compliance with the requirements or the imposition of a recommendation, if the non-conformity is of a minor nature or is an exceptional occurrence, or
  - the suspension of the **EM** notation, if the non-conformity is of a major nature or a recurrence.
- A defect or a deficiency is found in applying the PMS.  
The actions to be taken are the same as stated above both for repair of machinery installations and for the application of the PMS.
  - An unexpected defect or deficiency is found or a failure occurs, i.e. not as a result of lack of maintenance or failure in the application of the PMS.

### **6.5.3** (1/11/2022)

The withdrawal of the **EM** notation may be decided in different cases, such as:

- recurrent suspension of the **EM** notation
- suspension of the **EM** notation for more than a given period (i.e. 3 months)
- expiry or withdrawal of class.

## SECTION 41

## CARGO PIPING PROTECTED (CPP)

### 1 General

#### 1.1 Application

##### 1.1.1 (1/1/2023)

The additional class notation **CPP** is assigned, in accordance with Pt A, Ch 1, Sec 2, [6.14.63], to ships having all cargo piping and valve control piping located above the double bottom and complying with the requirements of this Section.

### 2 Cargo Piping - Pollution Prevention Measures

#### 2.1 Routing

##### 2.1.1 (1/1/2023)

For oil tankers and oil carriers of 5,000 tonnes deadweight and above, cargo piping, including cargo tank vent and sounding pipes, is not to pass through ballast tanks. Short runs of such pipes may be permitted provided they have all joints welded and are of wall thickness not less than that in Pt C, Ch 1, Sec 10, Tab 5 or equivalent construction. See also Pt E, Ch 7, Sec 4, [2.1.3] and Pt E, Ch 25, Sec 4, [2.1.3] for ballast pipe routing.

##### 2.1.2 (1/1/2023)

For vessels less than 5,000 tonnes deadweight, cargo piping passing through ballast tanks is to be steel with a minimum thickness according to Pt C, Ch 1, Sec 10, Tab 5, or equivalent construction. In such cargo piping, all joints are to be welded or have extra heavy flanges; no sliding-type expansion joint is permitted. The number of flanged joints is to be kept to a minimum.

##### 2.1.3 (1/1/2023)

Where the ship is assigned with the **CPP** notation, cargo piping and valve control piping installed in pipe tunnel or duct keel are also to be located above the double bottom.

#### 2.2 Stripping and small diameter lines

##### 2.2.1 (1/1/2023)

For crude oil carriers of 20,000 tonnes deadweight and above and product carriers of 30,000 tonnes and above, means are to be provided to drain all cargo tanks and all oil lines at completion of cargo discharge, where necessary by connection to a stripping device. The line and pump drainings are to be capable of being discharged either ashore and to a cargo tank or a slop tank. For discharge ashore a special small diameter line is to be provided and is to be connected to the vessel's deck discharge manifold outboard of the manifold valves on both sides of the vessel.

The cross-sectional area of the small diameter line is not to exceed 10% of that of the main cargo discharge line.

In order to minimize the possibility of flammable vapors being admitted to the cargo pump room, vents from drain tanks serving automatic stripping systems are to terminate in the weather and be fitted with corrosion resistant flame-screens or pressure/vacuum relief valves. Alternatively, the vents may be led to the slop tank.

#### 2.3 Sea chests

##### 2.3.1 (1/1/2023)

Where it is necessary to provide a sea connection to the cargo oil pumps to enable ballasting of cargo tanks during severe weather conditions, tank cleaning, etc., a means of isolating the pumps from the sea chests when they are not being used for this operation is to be provided. This is to be achieved by a blank flange or a removable spool piece. The spool piece, if used, is to be stowed as in [2.4] below. A shut-off valve is to be fitted on each side of the blank flange or the removable spool piece.

Alternatively, two valves are to be installed at the sea chest connection. One of these valves is to be capable of being locked in closed position and means - such as a test cock - is to be provided for detecting leakage past these valves.

#### 2.4 Connection to ballast system

##### 2.4.1 (1/1/2023)

Connection of the cargo system to the ballast system is only permitted by a removable spool piece in an emergency. The arrangements of the spool piece are to include:

- a non-return valve to prevent cargo from entering the ballast system, and
- shut-off valves and blind flanges on both the ballast end and the cargo end of the connection.

The spool piece is to be stowed in a conspicuous manner so that it may be readily available whenever the need arises. A permanent notice is to be displayed to prohibit unauthorized use of spool piece.

#### 2.5 Crude oil washing system

##### 2.5.1 (1/1/2023)

For crude oil carriers of 20,000 tonnes deadweight and above, the crude oil washing system is to comply with MARPOL 73/78, Annex I, Reg. 33 and IMO Resolution A.446(XI) "Revised specifications for the design, operation and control of crude oil washing systems", as amended by Resolutions A.497(XII) and A.897(21).

Where a crude oil washing system is fitted on a vessel of less than these deadweight sizes, only requirements concerning safety need be complied with.

The crude oil washing system is to be operated only when the cargo tank is inerted with an inert gas system complying with Part C, Chapter 4.

## **2.6 Slop tanks**

### **2.6.1 (1/1/2023)**

For oil tankers and oil carriers of 150 gross tonnage and above, slop tanks of number and sizes complying with Pt E, Ch 7, Sec 4, [5.2] and Pt E, Ch 25, Sec 4, [5.2] and MAR-

POL 73/78, Annex I, Reg. 29 are to be provided to receive dirty ballast residues, tank washings and other oil residues.

Slop tanks are to be so designed in respect of the position of inlets, outlets, baffles or weirs where fitted, so as to avoid excessive turbulence and entrainment of oil or emulsion with water.

## SECTION 42

# COATING PERFORMANCE STANDARD IN CARGO OIL TANKS (CPS-COT)

### 1 General

#### 1.1 Application

##### 1.1.1 (1/1/2023)

The additional class notation **CPS-COT** is assigned, in accordance with Pt A, Ch 1, Sec 2, [6.14.64], to crude oil tankers of new construction with cargo oil tanks provided with protective coatings complying with the requirements of this Section.

The additional class notation **CPS-COT** indicates that a crude oil tanker meets the Performance Standard for Protective Coatings for Cargo Oil Tanks of Crude Oil Tankers in IMO Resolution MSC.288(87).

##### 1.1.2 (1/1/2023)

The criteria for the selection, application and maintenance of protective coatings in cargo oil tanks provided in this Section, are based on the following international requirements:

- a) IMO Resolution MSC.288(87), Performance Standard for Protective Coatings for Cargo Oil Tanks of Crude Oil Tankers (IMO PSPC-COT).
- b) IACS UI SC259, Unified Interpretations for Application of SOLAS Regulation II-1/3-11 Performance Standard for Protective Coatings for Cargo Oil Tanks of Crude Oil Tankers (PSPC-COT), adopted by IMO Resolution MSC.288(87).
- c) IACS UR Z17, IACS Procedural Requirements for Service Suppliers.

A different "coating performance standard", which may have been chosen in the agreement between the shipyard and the Owner, may be accepted as a reference standard provided that the Society deems it at least equivalent to the above-mentioned standard.

The reference "coating performance standard" is to be appended as an enclosure to the Certificate of Classification of those ships to which the notation is assigned.

##### 1.1.3 (1/1/2023)

The assignment of the notation **CPS-COT** is subject to the verification of the "main work phases" indicated in Sec 12, Tab 1, schedule A) by means of the "survey activities" identified at the milestones indicated in Sec 12, Tab 1, schedule B), as described in Sec 12, [3].

#### 1.2 Definitions

##### 1.2.1 (1/1/2023)

Unless otherwise specified, the definitions used in this Section are those in Sec 12, [1.2].

For the purpose of this Section, crude oil tanker is defined as in Annex I of MARPOL 73/78.

### 2 Coating selection and specification

#### 2.1 General principles

##### 2.1.1 (1/1/2023)

The ability of the coating system to reach its target useful life depends on the selected type of coating system, steel preparation, application and coating inspection and maintenance. All these aspects contribute to the good performance of the coating system.

##### 2.1.2 (1/1/2023)

Inspections of surface preparation and coating processes are to be agreed upon between the Owner, the shipyard and the coating Manufacturer and submitted to the Society for review, prior to the commencement of the shipbuilding process, in order to check that it complies with the basic coating system requirements shown in Tab 1.

Clear evidence of these inspections is to be reported and be included in the Coating Technical File (see [2.2]).

##### 2.1.3 (1/1/2023)

The following aspects are to be taken into account for achieving the required coating performance:

- a) it is essential that the agreed technical specifications, procedures and various different steps in the coating application process (including but not limited to surface preparation) are strictly followed by the shipbuilder, in order to prevent premature decay and/or deterioration of the coating system;
- b) the effectiveness of these Rule requirements can be improved by adopting measures at the ship design stage such as reducing scallops, using rolled profiles, avoiding complex geometric configurations and ensuring that the structural configuration permits easy access for tools and to facilitate cleaning, drainage and drying of the space to be coated;
- c) these Rule requirements are based on experience from Manufacturers, shipyards and ship operators and are not intended to exclude suitable alternative systems or innovative approaches that might be developed and applied in the future, provided that they demonstrate a level of performance at least equivalent to that specified in this Section. Acceptance criteria for alternative systems are given in [2.8].

##### 2.1.4 (1/1/2023)

The class notation **CPS-COT** is not intended to be and shall not amount to a warranty of good performance of the coating nor does it replace the contractor warranty granted by the shipyard and/or paint Manufacturer or Supplier.

## 2.2 Coating Technical File

### 2.2.1 (1/1/2023)

Specification of the coating system applied to the cargo oil tanks, records of the shipyard's and Owner's coating work, and detailed criteria for coating selection, job specifications, inspection, maintenance and repair are to be documented in the Coating Technical File, which is to be reviewed by the Society.

### 2.2.2 (1/1/2023)

The Coating Technical Files is to contain at least the information required in Sec 12, [2.2].

## 2.3 Health and safety

### 2.3.1 (1/1/2023)

The shipyard is responsible for implementation of national regulations to ensure the health and safety of individuals and to minimise the risk of fire and explosion.

## 2.4 Coating Standard

### 2.4.1 Performance Standard (1/1/2023)

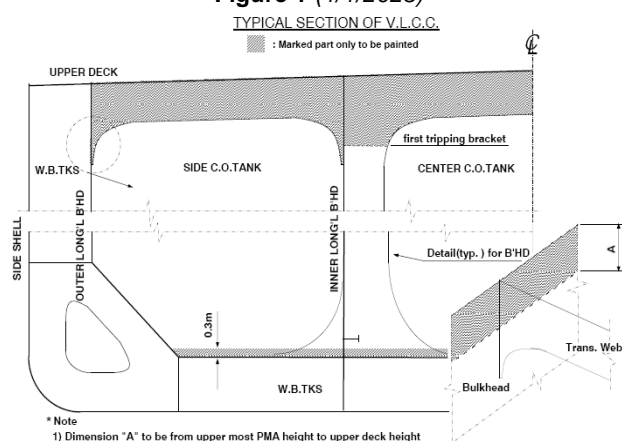
This coating performance standard is based on specifications and requirements which intend to provide a target useful life of 15 years, which is considered to be the time period, from initial application, over which the coating system is intended to remain in "GOOD" condition. The actual useful life will vary, depending on numerous variables including actual conditions encountered in service.

### 2.4.2 Area of application (1/1/2023)

The following areas are the minimum areas that shall be protected according to this coating performance standard:

- deckhead with complete internal structure, including brackets connecting to longitudinal and transverse bulkheads. In tanks with ring frame girder construction the underdeck transverse framing to be coated down to level of the first tripping bracket below the upper faceplate;
- longitudinal and transverse bulkheads to be coated to the uppermost means of access level. The uppermost means of access and its supporting brackets to be fully coated;
- on cargo tank bulkheads without an uppermost means of access the coating to extend to 10% of the tanks height at centreline but need not extend more than 3 m down from the deck;
- Flat inner bottom and all structure to height of 0.3 m above inner bottom to be coated.

Figure 1 (1/1/2023)



### 2.4.3 Special application (1/1/2023)

It is recommended that this standard is applied, to the extent practicable, to those portions of means of access provided for inspection within the areas specified in [2.4.2] that are not integral to the ship structure, such as rails, independent platforms, ladders, etc. Other equivalent methods of providing corrosion protection for non-integral items may also be used, provided they do not impair the performance of the coatings of the surrounding structure. Access arrangements that are integral to the ship structure, such as stiffener depths for walkways, stringers, etc., are to fully comply with this Standard when located within the coated areas.

It is also recommended that supports for piping, measuring devices, etc., be coated as a minimum in accordance with the non-integral items indicated in the above paragraph.

### 2.4.4 Basic coating requirements (1/1/2023)

The requirements for protective coating systems to be applied at ship construction for cargo oil tanks meeting the performance standard specified in [2.4.1] are listed in Tab 1.

Coating Manufacturers are to provide a specification of the protective coating system to satisfy the requirements of Tab 1.

The Society will verify the Technical Data Sheet and Statement of Compliance or Type Approval Certificate for the protective coating system.

The shipyard is to apply the protective coating in accordance with the verified Technical Data Sheet and its own verified application procedures.

**Table 1 : Basic coating system requirements for the notation CPS-COT (1/1/2023)**

Item	Requirement	Reference standard
1 - Design of coating system		
a) Selection of the coating system	<p>The selection of the coating system is to be considered by the parties involved with respect to the service conditions and planned maintenance. The following aspects, among other things, shall be considered:</p> <ul style="list-style-type: none"> <li>a) location of space relative to heated surfaces;</li> <li>b) frequency of cargo operations;</li> <li>c) required surface conditions;</li> <li>d) required surface cleanliness and dryness;</li> <li>e) supplementary cathodic protections, if any (where coating is supplemented by cathodic protection, the coating is to be compatible with the cathodic protection system);</li> <li>f) permeability of the coating and resistance to inert gas and acids; and</li> <li>g) appropriate mechanical properties (flexibility, impact resistance).</li> </ul> <p>The Coating Manufacturer is to supply products with documented satisfactory performance records and technical data sheets. The Manufacturer is also to be capable of rendering adequate technical assistance. Performance records, technical data sheets and technical assistance (if given) are to be recorded in the Coating Technical File. Coatings for application underneath sun-heated decks or on bulkheads forming boundaries of heated spaces are to be able to withstand repeated heating and/or cooling without becoming brittle.</p>	
b) Coating type	<p>Epoxy based systems</p> <p>Other coating systems are to have performance according to the test procedure in App 4.</p> <p>A multi-coat system with each coat of contrasting colour is recommended.</p> <p>The top coat is to be of a light colour in order to facilitate in-service inspection.</p> <p>Consideration is to be given to the use of enhanced coatings in way of suction bellmouths and heating coil down-comers.</p> <p>Consideration is to be given to the use of supplementary cathodic protection where there may be galvanic issues.</p>	
c) Coating test	<p>Epoxy-based systems tested prior to the date of entry into force of this Standard in a laboratory by a method corresponding to the test procedure in App 4 or equivalent, which as a minimum meets the requirements for rusting and blistering, or which have documented field exposure for 5 years with a final coating condition of not less than "GOOD", may be accepted.</p> <p>For epoxy-based systems approved on or after entry into force of this Standard, testing according to the procedure in App 4, or equivalent, is required.</p>	



Item	Requirement	Reference standard
d) Job specification	<p>There are to be a minimum of two stripe coats and two spray coats, except that the second stripe coat, by way of welded seams only, may be reduced in scope where it is proven that the NDFT can be met by the coats applied in order to avoid unnecessary over thickness. Any reduction in scope of the second stripe coat is to be fully detailed in the Coating Technical File.</p> <p>Stripe coats are to be applied by brush or roller. A roller is to be used for scallops, ratholes, etc. only.</p> <p>Each main coating layer is to be appropriately cured before application of the next coat, in accordance with the coating Manufacturer's recommendations. Job specifications are to include the dry-to-recoat times and walk-on time given by the manufacturer. Surface contaminants such as rust, grease, dust, salt, oil, etc. are to be removed prior to painting. The method to be according to the paint manufacturer's recommendations. Abrasive inclusions embedded in the coating are to be removed.</p>	
e) NDFT (nominal total dry film thickness)	<p>NDFT 320 µm with 90/10 rule for epoxy based coatings, other systems to the coating Manufacturer's specifications. Maximum total dry film thickness according to Manufacturer's detailed specifications.</p> <p>Care is to be taken to avoid increasing the thickness in an exaggerated way. Wet film thickness is to be regularly checked during application.</p> <p>Thinner is to be limited to those types and quantities recommended by the Manufacturer.</p>	Type of gauge and calibration in accordance with SSPC-PA2:2004 Paint Application Specification No.2.
2. Primary surface preparation		
a) Blasting and profile	<p>Sa 2½, with profiles between 30-75 µm</p> <p>Blasting is not to be carried out when:</p> <p>(i) the relative humidity is above 85%; or</p> <p>(ii) the surface temperature of steel is less than 3°C above the dew point.</p> <p>Checking of the steel surface cleanliness and roughness profile is to be carried out at the end of the surface preparation and before the application of the primer, in accordance with the Manufacturer's recommendations.</p>	ISO 8501-1 ISO 8503-1/2
b) Water soluble salt limit equivalent to NaCl	≤ 50 mg/ m <sup>2</sup> of sodium chloride	ISO 8502-9
c) Shop primer	<p>Zinc containing inhibitor free zinc silicate based or equivalent.</p> <p>Compatibility with main coating system is to be confirmed by the coating Manufacturer.</p>	
3. Secondary surface preparation		
a) Steel condition	<p>The steel surface is to be prepared so that the coating selected can achieve an even distribution at the required NDFT and have an adequate adhesion by removing sharp edges, grinding weld beads and removing weld spatter and any other surface contaminant in accordance with ISO 8501-3 grade P2.</p> <p>Edges are to be treated to a rounded radius of minimum 2 mm, or subjected to three pass grinding or at least equivalent process before painting.</p>	ISO 8501-3

Item	Requirement	Reference standard
b) Surface treatment	<p>Sa 2½ on damaged shop primer and welds. Sa 2 removing at least 70% of intact shop primer which has not passed a pre-qualification certified by test procedures specified in 1.c) of this Table.</p> <p>If the complete coating system comprising epoxy based main coating and shop primer has passed a pre-qualification certified by test procedures specified in 1.c) of this Table, intact shop primer may be retained provided the same epoxy coating system is used. The retained shop primer is to be cleaned by sweep blasting, high-pressure water washing or equivalent method.</p> <p>If a zinc silicate shop primer has passed the pre-qualification test specified in 1.c) of this Table, as part of an epoxy coating system, it may be used in combination with other epoxy coatings certified under 1.c) of this Table, provided that the compatibility has been confirmed by the manufacturer by the test with reference to the immersion test of App 4 or in accordance with the Performance standard for protective coatings for cargo oil tanks of crude oil tankers (resolution MSC.288(87)).</p>	ISO 8501-1
c) Surface treatment after erection	<p>Erection joints St 3 or better or Sa 2½ where practicable. For inner bottom:</p> <ul style="list-style-type: none"> <li>• Damages up to 20% of the area to be coated to be treated to minimum St 3.</li> <li>• Contiguous damage over 25 m<sup>2</sup> or over 20% of the area to be coated, Sa 2½ is to be applied.</li> </ul> <p>For underdeck:</p> <ul style="list-style-type: none"> <li>• Damages up to 3% of the area to be coated to be treated to minimum St 3.</li> <li>• Contiguous damage over 25 m<sup>2</sup> or over 3% of the area to be coated, Sa 2½ is to be applied.</li> </ul> <p>Coating in overlap to be feathered.</p>	
d) Profile requirements	In the case of full or partial blasting 30-75 µm, otherwise as recommended by the coating Manufacturer.	ISO 8503-1/2
e) Dust	Dust quantity rating "1" for dust size class "3", "4" or "5". Lower dust size classes are to be removed if visible on the surface to be coated without magnification.	ISO 8502-3
f) Water soluble salts limit equivalent to NaCl after blasting/grinding	≤ 50 mg/ m <sup>2</sup> of sodium chloride	ISO 8502-9
g) Contamination	No oil contamination. Paint manufacturer's recommendations should be followed regarding any other contamination between coats.	
4. Miscellaneous		
a) Ventilation	Adequate ventilation is necessary for the proper drying and curing of coating. Ventilation is to be maintained throughout the application process and for a period after application is completed, as recommended by the coating Manufacturer.	
b) Environmental conditions	Coating is to be applied under controlled humidity and surface conditions, in accordance with the Manufacturer's specifications. In addition, coating is not to be applied when:	
<ul style="list-style-type: none"> <li>(i) the relative humidity is above 85%; or</li> <li>(ii) the surface temperature is less than 3°C above the dew point; or</li> <li>(iii) any other requirements of the paint manufacturer are not being met.</li> </ul>		

Item	Requirement	Reference standard
c) Testing of coating	Destructive testing is to be avoided. Sample dry film thickness is to be measured after each coat for quality control purposes and the total dry film thickness is to be confirmed after completion of final coat, using appropriate thickness gauges.	SSPC-PA2: 2004
d) Repair	Any defective areas, e.g. pin-holes, bubbles, voids, etc., are to be marked up and appropriate repairs effected. All such repairs are to be re-checked and documented.	

## 2.5 Coating system approval

### 2.5.1 (1/1/2023)

Results from prequalification tests of the coating system (see 1.3 of Tab 1) are to be documented, and a Statement of Compliance or Type Approval Certificate is to be issued if found satisfactory by a third party, independent of the coating Manufacturer.

## 2.6 Coating inspection requirements

### 2.6.1 (1/1/2023)

The requirements in Sec 12, [2.6] apply.

## 2.7 Verification requirements

### 2.7.1 (1/1/2023)

The requirements in Sec 12, [2.7] apply.

## 2.8 Alternative systems

### 2.8.1 (1/1/2023)

All systems that are not an epoxy based system applied according to Tab 1 are defined as an alternative system.

### 2.8.2 (1/1/2023)

The requirements of this Section are based on recognised and commonly used coating systems. It is not meant to exclude other, alternative, systems with proven equivalent performance, for example non-epoxy based systems.

### 2.8.3 (1/1/2023)

Acceptance of alternative systems will be subject to documented evidence that they ensure a corrosion prevention performance at least equivalent to that indicated in this Section, by either:

- a) testing according to this standard; or
- b) The coating condition shall not be less than "GOOD" after five years.

## 3 Survey activities

### 3.1 General

#### 3.1.1 (1/1/2023)

The requirements in Sec 12, [3] apply.

## SECTION 43

## DIGITAL SHIP (D)

### 1 General

#### 1.1 Application

##### 1.1.1 (1/1/2023)

The additional class notation **DIGITAL SHIP (D)** is assigned to ships fitted with one or more approved electronic system/digital tool complying with the requirements of this section.

A Certificate of Compliance may be issued to ships not classed with the Society, fulfilling the requirements of this section. The certificate of compliance is valid for a period of 5 years, subject to annual confirmation.

### 2 Definitions

#### 2.1

##### 2.1.1 (1/1/2023)

- Documentary data is the electronic collection of ship's records, logbooks and storage of other documents in electronic format.
- Data Storage is the operation of saving and retention of recorded data.
- Owner, in this section, means Ship Owner or Ship Management Company.
- Stored data is the value recorded with identification of the person that saved it and time saved.
- Data Signature is the identification of the person that recorded the data by ID and password or more stringent identification standards.
- Time stamp is the data reference time expressed in UTC.

### 3 Documents to be submitted

#### 3.1

##### 3.1.1 (1/1/2023)

The following documents are to be submitted for information:

- a) list of software applications covered by the notation,
- b) list of records, logbooks and documents managed,
- c) list of data transferred ashore, when applicable,
- d) software quality and maintenance documentation.

Depending on the ship arrangement and software, additional drawings or documents may be required at Society's discretion.

Documents under b), c) and d) are not required in case the software is type approved by the Society.

### 4 Requirements

#### 4.1 General

##### 4.1.1 (1/1/2023)

The ship is to be fitted with one or more approved electronic system/digital tool:

- enabling the collection on board of documentary data in place of paper copies;
- duplicated by a secondary means or by the possibility to transmit data ashore keeping synchronized the two data storage databases;
- capable of sharing stored data with the Society.

For those documents that are not generated by the company/crew and are provided in paper form as original, an electronic copy is to be uploaded and kept updated in the system under Owner's responsibility.

##### 4.1.2 (1/1/2023)

Users are to be provided with personal ID and password to ensure that data are inserted by authorized personnel according to procedures and responsibility defined by ISM and/or, national/international regulations and/or other applicable standard/rules/procedures.

Depending on the data to be managed and the applicable standard/rules/procedures, stronger user authentication can be applied (such as MFA-Multi Factor Authentication).

Access to the data is to be monitored and secured by the Owner.

#### 4.2 Data stored (Data Signature and Time Stamp)

##### 4.2.1 (1/1/2023)

Data recorded on board are to be stored with association to the data source (e.g. person ID who uploaded/filled in the data or the reference to the automatic acquisition system) and the time when data were recorded (UTC time).

Any update to the data stored is to be associated to the data source (e.g. person ID who made the update) and the time at which the data was stored (UTC time).

#### 4.3 Redundancy

##### 4.3.1 (1/1/2023)

A data back-up is to be available in case of failure of the main computer/electronic system on board. The back-up can be on a secondary means on board or ashore.

In both cases synchronization between the main computer/electronic system on board and the back-up one, on board or ashore, is to be managed automatically by the system.

In case the back-up is ashore, stored data are to be transferred ashore automatically by an available trusted

internet connection, and operation of the system on board must not be impaired by the lack of internet or/and third parties' connectivity.

Evidence of last database synchronization with ashore is to be recorded and available to the Society for proper traceability.

#### 4.4 Data shared with the Society

##### 4.4.1 (1/1/2023)

The electronic system/digital tool is to be capable of providing to the Society a secure and trusted remote access to the data stored in the database on board or ashore, for the

scope of verifying the documentation applicable to the surveys/audits/verifications/approvals performed by the Society for the ship or for the management company.

Access to data can be granted with direct access to the software and data itself or to defined reports/views.

The list in Tab 1 is provided as a guidance to identify if the data to which the Society can have access are in the scope of the surveys/audits/verifications/approvals performed by the Society.

Data not part of the list in Tab 1 can be evaluated on a case-by-case basis for the assignment of notation.

**Table 1 : List of data that can be accessible to the Society (1/1/2023)**

ALL SHIPS	
Class	<ul style="list-style-type: none"> <li>• Analysis of the quality of the oil for thermal oil boilers</li> <li>• Repairs and maintenance log book for boiler and incinerator</li> <li>• Last shaft seal oil analysis</li> <li>• Shaft bearing temperature (MONSHAFT notation)</li> <li>• PMS/CBM data</li> </ul>
SOLAS	<ul style="list-style-type: none"> <li>• Last annual service VDR - EPIRB - SART - AIS - LRIT - GMDSS last survey report</li> <li>• Last annual service: EEBD - Breathing Apparatus - Immersion Suit - Portable Fire extinguishers</li> <li>• Last Compass deviation table</li> <li>• Gas Detector last calibration</li> <li>• Last Annual and/or Biennial CO<sub>2</sub> Service</li> <li>• Last LSA Annual Service (lifeboats, liferafts, rescue boats)</li> <li>• Last Foam analysis of fixed fire extinguishing system</li> <li>• Last Sprinkler water chemical analysis (only for hi-fog system)</li> <li>• Log-book Drills (LSA and steering gear)</li> <li>• Alternative design SOLAS (if any, refer to details on SOLAS certificates)</li> <li>• Record of Condition of assignment of load lines</li> <li>• Intact stability booklet</li> <li>• Last version of the Continuous Synopsis Record</li> <li>• MES deployment calendar (if fitted)</li> <li>• Emergency towing arrangements (for oil tanker in approved form)</li> <li>• Approved Cargo securing Manual (for ship carrying dangerous goods)</li> </ul>
MARPOL	<ul style="list-style-type: none"> <li>• Oil Water Separator last calibration service (IOPP)</li> <li>• Oil record Book Part I</li> <li>• Garbage record book</li> <li>• Garbage management plan</li> <li>• Bunker delivery notes</li> <li>• SOPEP</li> <li>• EIAPP and Technical files for MMEE and DDGG</li> <li>• On board monitoring manual (OMM) of EGCS record book (scrubber if fitted)</li> <li>• Calibration of the monitoring equipment (if scrubber is fitted)</li> <li>• Fuel changeover procedures (if any)</li> </ul>

<b>ALL SHIPS</b>	
ISM CODE	<ul style="list-style-type: none"> <li>• SMS manual and relevant procedures and supporting forms/checklists</li> <li>• DOC certificate</li> <li>• Risk assessment procedures/policy</li> <li>• Cybersecurity procedures</li> <li>• Drills/exercises planning and relevant records</li> <li>• Man overboard procedures</li> <li>• PSC records and relevant follow-up documentation</li> <li>• Accident, near miss and non-conformity reports for injury/pollution and follow up by Company</li> <li>• Records of internal audits and findings follow-up documentation</li> <li>• Record of spare parts for critical equipment</li> <li>• Actual crew list</li> <li>• Crew training records</li> <li>• Maintenance on board records/documentation</li> </ul>
BWM	<ul style="list-style-type: none"> <li>• Ballast record book</li> <li>• Ballast management plan</li> </ul>
Other	<ul style="list-style-type: none"> <li>• Lifts - Escalator last service</li> <li>• Last PSC report</li> <li>• DCS Statement of Compliance</li> <li>• MRV Certificate of Compliance</li> <li>• MRV and DCS recordings</li> <li>• Officers STCW Certificates and Flag endorsement, when applicable</li> </ul>
<b>OIL and CHEMICAL TANKERS / BULK CARRIES</b>	
<ul style="list-style-type: none"> <li>• Oil record Book Part II</li> <li>• Repair history and Condition Evaluation Report</li> <li>• Ship Construction File</li> <li>• SMPEP for Chemical Tankers</li> <li>• SOPEP for Oil Tankers</li> <li>• Ship's structures and Access Manual</li> <li>• Intact and damage stability on loading computer</li> <li>• Ship technical coating file for Oil Tankers</li> <li>• Procedures &amp; Arrangements Manual</li> <li>• Operating and Maintenance Manual for ODME and calibration certificate (MEPC.108(49))</li> <li>• Cargo Record Book for Chemical Tankers</li> <li>• VOC Plan for Crude Oil Tankers</li> </ul>	
<b>RO-RO (CARGO and PAX) / CONTAINER SHIPS</b>	
<ul style="list-style-type: none"> <li>• Approved Cargo Securing Manual</li> <li>• Onboard Maintenance Manual (OMM) for all doors of Ro-Ro</li> </ul>	
<b>TUGS</b>	
<ul style="list-style-type: none"> <li>• Operating instructions of Emergency release system</li> </ul>	

## SECTION 44

## FUEL SAMPLING

### 1 General

#### 1.1 Application

##### 1.1.1 (1/1/2023)

The additional class notation **FUEL SAMPLING** may be assigned, in accordance with Pt A, Ch 1, Sec 2, [6.14.65], to ships having the fuel oil supply system provided with sampling points complying with the requirements in Pt C, Ch 1, Sec 10, [11.10.5] and the additional ones in [2].

### 2 Requirements

#### 2.1 General

##### 2.1.1 (1/1/2023)

The sampling points in the fuel oil supply system are to comply with the requirements in [2.2] derived from IACS Recommendation for fuel oil treatment systems (IACS Rec.151).

#### 2.2 Location of sampling points

##### 2.2.1 (1/1/2023)

The sampling points are to be located as follows:

- a) after the transfer pump discharge,
- b) before and after the fuel cleaning equipment,
- c) after the fuel oil service tank, before any fuel change over valve, and
- d) before fuel enters the oil fuelled machinery (after fuel change over valve but before the booster pump).

##### 2.2.2 (1/1/2023)

Sampling points are to be provided at locations within the fuel oil system that enable samples of fuel oil to be taken in a safe manner.

The sampling points are to be in positions as far away as possible from any heated surface or electrical equipment to preclude impingement of fuel oil onto such surfaces or equipment under all operating conditions.

##### 2.2.3 (1/1/2023)

The positions of the sampling points are to be shown in the approved diagram of fuel oil system (Pt C, Ch 1, Sec 10, Tab 1) and the approved diagram is to be retained on board and presented to the surveyor during surveys.

## SECTION 45

## WIND ASSISTED PROPULSION SYSTEM (WAPS)

### 1 General

#### 1.1 Scope and application

##### 1.1.1 (1/6/2023)

The additional class notation **Wind Assisted Propulsion System (WAPS)** is assigned, in accordance with Pt A, Ch 1, Sec 2, [6.14.66], to ships with a wind propulsion system complying with the requirements of this Section.

This Section provides requirements on the design, installation and testing of wind propulsion systems on new and existing ships with regard to hull, stability and machinery, including piping and electrical systems, control, monitoring alarm and safety systems.

This Section considers the WAPS installations as additional propulsion or power generation means not essential for the safety and for the navigation of the ship and in case of failure the WAPS is to be brought to a safe status not impairing the propulsion power.

This Section is applicable to all wind propulsion technologies like sails (e.g. soft or rigid sails), wing-sails (e.g. wings or suction wings), kite-sails (e.g. towing kites), flattener rotors and wind turbines as defined in [1.1.2].

Depending on the available effective power of the WAPS - calculated according to IMO MEPC.1/Circ.896, as amended - the WAPS notation is assigned as follows:

- **WAPS-A** (Auxiliary) when the available effective power of the WAPS is equal or less than 15% of the propulsion power
- **WAPS-H** (Hybrid) when the available effective power of the WAPS is more than 15% and equal or less than 60% of the propulsion power
- **WAPS-M** (Main) when the available effective power of the WAPS is more than 60% of the propulsion power.

The propulsion power is to be calculated according to the IMO MEPC.308(73) "2018 guidelines on the method of calculation of the attained energy efficiency design index (EEDI) for new ships" or according to the IMO MEPC.333(76) "2021 Guidelines on the method of calculation of the attained energy efficiency existing ship index (EEXI)". For those ships not subject to EEDI and EEXI MARPOL Annex VI regulations an alternative method for the calculation of the available effective power and of the propulsion power may be accepted on a case-by-case basis.

Alternative arrangements, designs and technologies not expressly mentioned or not in compliance with following perspective requirements may be accepted on a case-by-case basis provided that they are subject to a risk assessment as described in [1.3].

##### 1.1.2 (1/6/2023)

Depending on the type of the WAPS technology and its layout, the WAPS installation can be defined as follows:

- a) Sails-Modern rig: rig with one or further masts supporting mainsail and headsails, equipped with or without spreaders and supported by transverse shrouds and forestay and backstays. The sails are trimmed to the wind by the running rigging.
- b) Sails-Traditional rig: rig with further masts supported by transverse and longitudinal standing rigging shrouds, with yards supporting square sails and with headsails. The sails are trimmed to the wind by the running rigging.
- c) Sails-Free-standing rig: Rig that does not rely on shrouds and stays to keep the masts up. As a rule, self-supporting rigs have only head-sail trimmed to the wind by the running rigging. The mast can be fixed or turned by rotation.
- d) Sails-Free standing rotating rig: free rotating mast with integral rigid boom extending fore and aft of the mast supporting the sail tacks. The sails are trimmed to the wind by rotation of the mast.
- e) Sails-Modern square-rig: free-standing and rotating masts with curved yards rigidly connected to the mast. The canvas sails furl into the mast and are trimmed to the wind by the rotation of the mast. Similar system to those used by the old square-riggers like clipper ships. It may consist of in-furling boom system or in-furling mast system.
- f) Wing sail: wing, retractable or not, fixed to a free rotating mast with an integral long boom. The wing sails are trimmed to the wind by rotation of the mast. They may be configured as single foils or multiple foils attached to a single base and flaps may be used.
- g) Suction wings: directable wing with internal ventilated system to use boundary layer suction effect.
- h) Flettner Rotor: cylindrical structure fitted on the deck and mechanically driven by electrical or hydraulic motors. The cylinders spin to use the Magnus effect and generate forward thrust.
- i) Towing kites: kites are normally connected to a control pod at the fore-castle, deployed at high altitude at sea through control lines. One or more towing kites may be used, and they can be recovered on deck.
- j) Wind Turbines: directable rotors fixed on mast fitted with blades which may be used for converting the kinetic energy of wind into electrical energy or into thrust.

The wind assisted propulsion systems may be telescopic, retractable or recoverable when they are not operated in order to allow passages under the bridges, canals, rivers or loading/unloading operation or in case of bad weather.



Other types of WAPS may be evaluated on a case-by-case basis by the Society.

The notation **WAPS** may be completed with the commercial denomination of the technology identifying the type of installation as above, for example as follows:

- WAPS-A-Ventifoil
- WAPS-H-Rotor
- WAPS-M-Dyna Rigg.

## 1.2 Documentation to be submitted

### 1.2.1 (1/6/2023)

The documents listed in Tab 1 are to be submitted.

These documents are intended to be relevant to the WAPS, unless otherwise specified.

The list of documents requested is to be intended as guidance for the complete set of information to be submitted, rather than an actual list of titles.

The Society reserves the right to request the submission of additional documents in the case of non-conventional design or if it is deemed necessary for the evaluation of the system, equipment or components.

**Table 1 : Documents to be submitted (1/6/2023)**

No.	I/A (1)	Documents
1	I	General arrangement of the wind assisted propulsion system (WAPS) including location and layout of electrical and hydraulic components
2	A	Operating manual including procedures for emergency operation and allowable weather conditions for the use of WAPS
3	I	Description of the functioning and safety system preventing overloads on the WAPS system
4	A	Block Diagram for the control, monitoring and safety system
5	I	Forces distribution at the design conditions as applicable for the WAPS components transmitting thrust or torque
6	I	Aerodynamic test report of the profiles (if any)
7	I	Risk Assessment Report (HAZID, FMECA or HAZOP)
8	A	Construction drawings of the standing rigging structure specifying the materials and connections between the different elements of the standing rigging for WAPS with sails as applicable
9	A	Construction drawings of the running rigging structure specifying the materials and the mechanical characteristics of the different elements of the running rigging for WAPS with sails as applicable
10	I	Information about the shrouds and stays pre-tensioning values, specifying the pre-tensioning control process at construction and in operation (if any) for WAPS with sails as applicable
11	A	Information about halyard, sheet ropes characteristics and sail furling devices (if any) for WAPS with sails as applicable
12	A	Information of chain plates, pad eyes and similar elements supporting the forces reactions induced by the standing rigging WAPS with sails as applicable
13	A	Characteristics of winch, clutch, sheet track rails and sheave supports transmitting the forces reactions induced by the running rigging for WAPS with sails as applicable
14	A	Local hull structure reinforcements in way of WAPS foundation, specifying the forces reactions induced by the running rigging (winch, clutch, sheet track rails, sheave supports, if any) as applicable
15	A	Piping diagram of hydraulic installations intended to power the WAPS system and the operating running rigging system (if any)
16	I	Power supply wiring diagram of the electrical installations intended to power the WAPS system and the operating running rigging system (if any)
17	A	Mast rotating system and its equipment, system of measurement of the strain gauge and all systems provided as automatic release systems to avoid wind overload on the WAPS system when taken into account for the scantling of the standing rigging
18	I	Strength Calculation of all WAPS main components transmitting forces
19	A	Operating and Maintenance Manual (OMM) including a corrosion protection plan for WAPS elements
<b>(1)</b> A = to be submitted for approval I = to be submitted for information		

No.	I/A (1)	Documents
20	I	EEDI or EEXI preliminary technical file including the WAPS available effective power and its comparison with the propulsion power
21	I	Master Instruction for the use of WAPS (e.g. sailing table)
(1) A = to be submitted for approval I = to be submitted for information		

### 1.3 Risk assessment

#### 1.3.1 (1/6/2023)

A risk assessment is to be conducted to ensure that the risks, arising from the use of WAPS and potentially affecting persons on board, the environment, the structural strength or the integrity of the ship are addressed. Considerations are to be given to the hazards associated with physical layout, operation and maintenance, following any reasonably foreseeable failure.

#### 1.3.2 (1/6/2023)

The assumptions for the risk assessment are to be agreed by a team of experts acceptable to the Society. It may include a representative of Class, Flag Administration, owner, builder or designer, and consultants having the necessary knowledge and experience in safety, design and/or operation as necessary for the specific evaluation at hand. Other members may include marine surveyors, ship operators, safety engineers, equipment manufacturers, human factors experts, naval architects and marine engineers, according to the problem under scope.

#### 1.3.3 (1/6/2023)

The risk assessment can be qualitative or quantitative - using the different methods HAZID, FMECA and HAZOP, as deemed appropriate - and is to cover the following aspects:

- Evaluation of a suitable number of worst-case scenarios for the identification of the accidental set(s) of loads applicable to the WAPS main components and WAPS foundations/connection to the ship.
- Extreme conditions for the WAPS configurations during navigation (according to the navigation and operating area notations assigned, see Pt A, Ch 1, Sec 2, [5]) but with WAPS not operating (e.g. stowed condition, bare masts and/or similar). The outcome are the set(s) of loads applicable to the WAPS main components and WAPS foundations/connection to the ship. Increase in pressure forces on WAPS caused by spray water may be additionally considered as extreme load.
- Operating conditions envelop for the WAPS configurations during navigation (according to the navigation and operating area notations assigned, see Pt A, Ch 1, Sec 2, [5]) and harbor stay. The outcome are the set(s) of loads applicable to the WAPS main components and WAPS foundations/connection to the ship.
- Unacceptable level of structural vibrations of WAPS and ship structures as well resonance with ship. To be verified if a resonance analysis is needed for the WAPS system.
- Use of combustible materials for WAPS components (e.g. sails, rigging) increasing smoke, toxic and fire growth potential risks.

- Emergency operation for WAPS in case of severe weather (storm), wind overspeed and overload.
- Ice accretion on WAPS components.
- Maintenance of WAPS components located at highest points.
- Lightning protection.
- Crew training and human error.
- Reduced bridge visibility for the navigation. Possible drawbacks in terms of obstruction view from the navigation deck as well as obstruction of cargo handling are to be assessed.
- The need of CCTV system, for the proper monitoring of the WAPS operation from control station and for ship navigation/maneuvering operation, is to be assessed
- Sufficient bridge clearance is to be guaranteed by all the WAPS structures, especially in case WAPS tilting systems are not available or out of order.
- Corrosion and wearing of structure parts like masts, booms, spreader, yards, cylinders, blades, wings and moving parts.
- Identification of critical machinery items whose single failure could impair the safe control of WAPS.
- Ignition risks assessment for WAPS system installed in hazardous area

Guidance on risk analysis techniques can be found in the Tasneef "Guide on Risk Analysis".

Guidance for the values of operational and extreme wind speeds can be found in the Tasneef "Rules for Loading and Unloading Arrangements and for other Lifting Appliances on Board Ships". Operational wind speeds can be taken as the ones corresponding to Case II and Case III (see Ch 5, Sec 3) while extreme wind speed can be taken as the one corresponding to Case IV.

## 2 Design requirements

### 2.1 Structure and outfitting

#### 2.1.1 (1/6/2023)

The structure of WAPS main components is to comply with the requirements applicable to the members of the Tasneef "Rules for Loading and Unloading Arrangements and for other Lifting Appliances on Board Ships".

The strength verifications are to be carried out as prescribed in Ch 14 for the different load cases (operations, extreme, accidental).

The connections of the WAPS to the outer hull plating, ordinary stiffeners and/or primary supporting members are to comply with the requirements of Part B, Chapter 7, taking also into account the local and hull girder loads described in Part B, Chapter 5. The scantlings of WAPS main compo-

nents and of the connection structural elements for the different design cases are to be checked for yielding, buckling and fatigue strength, using:

- WAPS loads defined by the designer (in operational and extreme cases, see [1.3]), taking into account lift and drag induced by apparent wind with gusts effect (specifying the associated combination of the WAPS configurations and the wind angle of attack), applicable wind speed profile, reactions forces on mast and boom induced by halyards or hooks, main sheet and pre-tensioning forces when provided in rigging elements (e.g. shrouds, stays).
- Acceleration Loads defined by the designer (in operational and extreme cases, see [1.3]), considering the ship motions in the longitudinal, vertical and transversal directions with reference to Pt B, Ch 5, Sec 3 and applicable navigation notation according to Pt A, Ch 1, Sec 2, [5]. The acceleration in case of a collision event is also to be taken into consideration.
- Accidental Loads set(s) from the scenario(s) as defined by the designer and identified in the risk assessment in [1.3].
- Resulting additional hull girder loads applied by the WAPS to the hull, if not negligible (depending on the WAPS technology selected). In case the additional hull girder loads are not negligible, the checks of Part B, Chapter 6 are to combine them in the most unfavourable conditions with the other hull girder loads for both yielding and buckling strength requirements.

#### 2.1.2 (1/6/2023)

All the structures of WAPS exposed to atmosphere are to be protected against corrosion and a corrosion protection plan is to be available on board. Coatings or other protective measures (e.g. corrosion addition) and identification of structural members more sensitive to corrosion are to be evaluated in the risk assessment in [1.3]. Hull structures supporting WAPS are to be designed with a corrosion addition as defined in Pt B, Ch 10, Sec 4, [3.1.3].

#### 2.1.3 (1/6/2023)

The characteristics of the steel or aluminium materials to be used in the construction of WAPS components (e.g. masts, booms, wings, rotors) are to be according to the requirements available in Pt B, Ch 4, Sec 1. The use of composite materials for blades, wings and sails and other components may be accepted case-by-case if these are type approved according to the Tasneef "Rules for the Type Approval of Components of Composite Materials Intended for Hull Construction".

Other materials may be considered on a case-by-case basis by the Society.

#### 2.1.4 (1/6/2023)

For ships intended to operate in areas with low air temperatures (below  $-10^{\circ}\text{C}$ ), e.g. regular service during winter seasons to Arctic or Antarctic waters, the steel materials in exposed WAPS structures are to be selected according to Pt B, Ch 4, Sec 1.

#### 2.1.5 (1/6/2023)

Rigging elements are to be designed, tested and inspected according to Tasneef "Rules for the masting and rigging of sailing ships" and Tasneef "Rules for the certification of sailing rigs", as far as applicable and practicable. Alternative methods for the design and testing of rigging may be evaluated on a case-by-case basis by the Society.

#### 2.1.6 (1/6/2023)

Steel wire ropes and fibre ropes for rigging are to be manufactured and tested according to Pt D, Ch 4, Sec 1.

#### 2.1.7 (1/6/2023)

For the calculation of the Equipment Number (EN) as established in Pt B, Ch 10, Sec 4 the additional projected area of WAPS system as foreseen in anchoring condition (i.e. not in sailing condition) is to be duly taken into consideration if the WAPS elements are not tiltable or retractable.

#### 2.1.8 (1/6/2023)

The supporting hull structures of winches and windlasses used for the control of the WAPS system are to be designed to withstand the foreseen loads according to Pt B, Ch 10, Sec 4, [3.9] taking into account the accidental loads set(s) as identified in the risk assessment required in [1.3].

#### 2.1.9 (1/6/2023)

Welded connections of WAPS elements are to be verified according to Tasneef "Rules for Loading and Unloading Arrangements and for other Lifting Appliances on Board Ships" Ch 14, [2.2.5].

Welded connections of WAPS elements are to be executed according to the approved plans with qualification of welding procedures as given in Part D, Chapter 5.

## 2.2 Stability

### 2.2.1 (1/6/2023)

Ships fitted with a WAPS are to comply with the intact stability requirements in Part B, Chapter 3 and possible additional requirements from the Administration. In general, two types of WAPS ships are identified:

- Small aerodynamic driving force in comparison to propeller thrust
- Small "sail area" in comparison to hull windage area
- Small heel angle due to aerodynamic heeling moment
- Stability verified according to Intact stability criteria based on IMO Resolution A.562(14) "Recommendation on a severe wind and rolling criterion (Weather Criterion) for the intact stability of passenger and cargo ships of 24 metres in length and over"
- Low inertia response to gusts
- Aerodynamic heeling moment can be counteracted using transverse ballast adjustments.

b) WAPS type II Ship has the following characteristics:

- Large aerodynamic driving force in comparison to propeller thrust
- Large "sail area" in comparison to hull windage area
- Large heel angle due to aerodynamic heeling moment
- Stability verified according to Intact stability criteria based on IMO Resolution A.562(14) "Recommendation on a severe wind and rolling criterion (Weather Criterion) for the intact stability of passenger and cargo ships of 24 metres in length and over"
- High inertia response to gust. The calculation of heeling moment may be carried out for specific wind profile whenever the sailing surface may vary upon Master adjustment.
- Aerodynamic heeling moment can be counteracted using transverse ballast adjustments.

**2.2.2 (1/6/2023)**

The additional projected lateral area (wind profile) and icing accretion (if any), and the added weight and centre of gravity due to the WAPS installation are to be considered in the intact stability calculation.

**2.2.3 (1/6/2023)**

The adverse impact of the additional heeling moment generated by any aerodynamic effect is to be considered in the intact stability calculations.

**2.2.4 (1/6/2023)**

The trim and stability booklet is to include additional guidance for the operation of the wind assistance equipment. The need to include considerations for operational envelopes or 'weather windows' for their deployment and retrieval will be dependent on the system installed. Intermediate settings of the wind propulsion system, between fully deployed and fully retrieved conditions also to be duly taken into account in the guidance.

**2.2.5 (1/6/2023)**

A wind force, to cover an extreme wind condition and the expected operational envelope, is to be agreed with the Society and is to be used to assess an additional wind heeling moment. Wind forces can be obtained from the following documents, however the value(s) used is(are) to be confirmed also with the Administration:

- MEPC.1/Circ.896 "2021 Guidance on treatment of innovative energy efficiency technologies for calculation and verification of the attained EEDI and EEXI"
- MSC.1/Circ.1200 "Interim Guidelines for Alternative Assessment of the Weather Criterion".

The wind heeling moment is to be used to assess the intact stability in line with section 2.3 of Part A of the 2008 IS Code.

The wing heeling lever  $I_{w1}$ , in paragraph 2.3.2 of Part A of the 2008 IS Code is to be modified to include the additional force as agreed with the Administration as follows:

$$I_{w1} = \frac{C_D \cdot Z_w}{Z} \cdot \frac{P \times A \times Z}{1000 \times g \times \Delta}$$

where:

P = wind pressure of 504 Pa + that arising from with agreed additional force from the WAPS

A = projected lateral area of the portion of the ship, WAPS parts and deck cargo above the waterline (m<sup>2</sup>)

Z = vertical distance from the centre of A to the centre of the underwater lateral area or approximately to a point at one half the mean draught (m)

Δ = displacement (t)

g = gravitational acceleration of 9.81 m/s<sup>2</sup>

C<sub>D</sub> = drag coefficient

Z<sub>w</sub> = heeling lever

(C<sub>D</sub> x Z<sub>w</sub>)/Z is to be obtained from the experiment or by calculation method. In any case this value is not to be taken less than 1.22.

In case of WAPS multiple systems, supporting evidence that combinations of forces and moments generated by the sails on the vessel do not negatively influence intact stability as well as maneuverability is to be provided, depending on the specific arrangement adopted for the sails. Additionally, if the sails are arranged in such a way that they shelter one another, variations of wind loads on them are to be accounted for by means of properly defined sheltering coefficients (i.e. wake effect).

**2.3 Machinery**

**2.3.1 (1/6/2023)**

The general requirements of Pt C, Ch 1, Sec 1 are applicable as far as practicable where the WAPS machinery items are considered not essential for the propulsion and the safety of the ship.

**2.3.2 (1/6/2023)**

Machinery items like drive and safety systems needed for the safe control or emergency operation of WAPS are considered as essential so that any single failure is not to lead to unsafe status for the WAPS. The critical machinery items are to be identified during the risk assessment required in [1.3].

**2.3.3 (1/6/2023)**

Hydraulic systems used for the movement of WAPS elements (e.g. tilting or driving systems including hydraulic components as motors, cylinders, pistons) are to comply with Pt C, Ch 1, Sec 10 and Pt C, Ch 1, Sec 14. In case the tilting system is considered as essential for the vessel in order to survive the worst scenario identified in the risk assessment in [3.3] at least two hydraulic power units and two actuating units (e.g. motors, cylinders) are to be provided with independent piping system or equivalent arrangement subject to a single failure analysis of passive components (e.g. pipes) and active components (e.g. valves, pumps).

**2.3.4 (1/6/2023)**

In general, all auxiliary piping systems (e.g. lubricating oil, cooling water, compressed air) relevant to the WAPS are to be designed, built, installed and tested according to Pt C, Ch 1, Sec 10.

**2.3.5 (1/6/2023)**

The hydraulic cylinders used for the tilting or driving system of WAPS are to be designed and tested according to Pt C, Ch 1, Sec 3.

**2.3.6 (1/6/2023)**

Retracted or tilted WAPS elements are to be provided with securing and locking arrangement which are to be simple to operate and easily accessible. The securing and locking devices are to be interlocked in such a way that they can be only operated in the proper sequence. Where hydraulic securing devices are applied, the system is to be mechanically lockable in closed position. This means that, in the event of loss of hydraulic fluid, the securing devices remain locked. The hydraulic system for securing and locking devices is to be isolated from other hydraulic circuits, when the WAPS is in tilted or retracted position.

**2.4 Electrical installations****2.4.1 (1/6/2023)**

The electrical installations and relevant electrical components for WAPS are to be designed and constructed according to the requirements in Part C, Chapter 2.

**2.4.2 (1/6/2023)**

For the electrical power supply, the WAPS is to be considered a service among those listed in Pt C, Ch 2, Sec 3, [2.2.5].

**2.4.3 (1/6/2023)**

In case the tilting system is considered as essential for the vessel in order to survive the worst scenario identified in the risk assessment in [1.3] at least two electrical power supplies and two actuating units (e.g. e-motors) are to be provided.

**2.4.4 (1/6/2023)**

As far as practicable, the electrical installations intended for the WAPS are not to be located in hazardous areas. In case it is not possible to avoid installation in hazardous areas, they are to be in compliance with requirements in Pt C, Ch 2, Sec 3, [10] and relevant risks and hazards are to be evaluated in the risk assessment in [1.3].

**2.4.5 (1/6/2023)**

A proper earth connection is to be fitted for the WAPS according to Pt C, Ch 2, Sec 12, [2]. The lightning and earthing system is to be designed in accordance with the requirements of IEC 60092-401.

**2.5 Control, Monitoring, Alarm and Safety Systems****2.5.1 (1/6/2023)**

Automatic control, alarm, and safety functions are to be provided for the wind propulsion system so that the operations remain within the preset parameters for different operation conditions. The system is to be designed to avoid a single failure event leading to a potentially dangerous situa-

tion. In the event of failure in the WAPS control, alarm and safety systems, an alarm is to be activated. The design of the WAPS automation is to avoid that failures or malfunctions cause danger to other essential services. The general requirements in Pt C, Ch 3, Sec 1 apply.

**2.5.2 (1/6/2023)**

All alarms of WAPS are to be triggered to a continuously manned control station. The control positions are to be inaccessible to unauthorised persons and located to have proper visibility of the WAPS to be operated.

**2.5.3 (1/6/2023)**

Computer based systems of WAPS technology, which provide control, alarm, monitoring, or internal communication functions, are to be in compliance with requirements in Pt C, Ch 3, Sec 3 for category II computer systems. Those which provide safety functions are to be assessed in the risk assessment in [1.3] to define their proper category.

**2.5.4 (1/6/2023)**

The WAPS control is to be performed by a single control device at the active control station indicating all alarms and provided with an emergency stopping device able to put the WAPS in a safe status (less wind resistance or sail furling) in case of the control system failure. Additionally, the WAPS is to be protected by a safety system which is automatically activated in the event of identified conditions leading to damage of associated machinery, WAPS elements or structural part. The safety system is to be capable of:

- restoring the normal functioning of WAPS (e.g. starting of stand-by components like pumps, motors)
- adjusting the configuration of WAPS elements to avoid overload (e.g. reducing the tension of lines for sails and kites, changing position of wings or rotor spin speed)
- bringing the WAPS in a safe configuration where wind forces are reduced as much as possible on the structures (e.g. furling/trimming of sails, stopping flettner rotor, neutral position of wings).

**2.5.5 (1/6/2023)**

The WAPS integrated safety system is to have the following characteristics:

- self-monitoring type in respect of internal failures
- "fail safe" design, so that any failure cannot result in an unsafe status for the WAPS
- independent from control and alarm system
- compliant with Pt C, Ch 3, Sec 2, [7].

**2.5.6 (1/6/2023)**

Separate indicator lights and audible alarms are to be provided on the navigation bridge and on the operating panel to show that the WAPS is tilted or retracted and that their securing and locking devices are properly positioned.

The indication panel is to be provided with a lamp test function or equivalent means. It is not to be possible to turn off the indicator light. The indicator system is to be designed on the fail-safe principle where the panel is provided with power failure alarm, earth failure alarm and indication of tilted/retracted WAPS elements and properly locked. The sensors of the indicator system are to be protected from water, ice formation and mechanical damage.

### 2.5.7 (1/6/2023)

The electronic and electrical components (e.g., sensors, cables, panels) are to be provided with type approval certificates according to Pt C, Ch 2, Sec 15, [2].

### 2.5.8 (1/6/2023)

Software version for the control, monitoring and safety of WAPS is to be recorded. Software modification is to be managed according to applicable quality procedure.

## 3 Operation and maintenance

### 3.1 Operating and Maintenance Manual

#### 3.1.1 (1/6/2023)

An Operating and Maintenance Manual (OMM) for the WAPS is to be provided on board and contain necessary information on:

- a) main particulars and design drawings of WAPS
  - description of the technology and its functioning theory
  - block diagram of automation and HMI description
  - power supply single line diagram
  - safety precautions for the normal and emergency operation
  - details of sailing configurations
  - list of components (e.g. winches, ropes, wires, cylinders, motors) relevant to rigging and tilting system
  - critical machinery items considered as essential
  - manufacturer's technical data sheets of components transmitting forces
- b) operating conditions envelop
  - WAPS emergency operating instructions
  - sailing operating conditions depending on weather
  - operational restrictions for the WAPS
  - safety system activation
  - ship heel and trim restrictions for the safe operation of WAPS
- c) maintenance
  - annual, intermediate, renewal inspections for WAPS elements
  - corrosion protection scheme for WAPS elements
  - maintenance intervals for WAPS components
  - manufacturer's maintenance instructions
- d) record of inspections
  - annual, intermediate, renewal inspections for WAPS elements
  - indications for the visual inspection of locking/securing devices, tilting system, rigging and supporting structure
  - verification criteria for the visual inspections
  - record of damages and repair.

### 3.2 Rig Booklet

#### 3.2.1 (1/6/2023)

For WAPS with rigging, a rig booklet is to be available on board. This manual is to supply master and crew with the instructions to correctly use and maintain the rig including:

- a) Clear operating instructions for master and crew
- b) Certificates of components subject to periodical test
- c) Main ship data
- d) Rig geometry
  - Key parameters, e.g.:
  - Reference design righting moments
  - Reference load case
  - Reference lightship data
- e) Bill of materials with the indication of suppliers and manufacturers, including at least:
  - mast tube
  - boom
  - standing rigging cables
  - inner forestay and runners cables
  - running rigging
  - furlers
  - mainsail track
  - sheaves and blocks
- f) Assembly sequence
- g) Mast
  - Spreaders attachment
  - Stepping
- h) Boom
  - Assembly sequence
  - Vang attachment
- i) Rigging
- j) Stepping sequence
- k) Tuning sequence
- l) Dock side tuning
- m) Tuning under sail

For the operating instructions mentioned in a) above, the following are to be taken into account:

- upwind/downwind
- true wind speed (TWS)
- apparent wind speed (AWS)
- mainsail - full / reef
- headsail
- heel angle
- sail reduction plan
- safe heeling angle - operating limits.

### 3.3 Access Arrangement

#### 3.3.1 (1/6/2023)

The space containing the tilting system or actuating system of the WAPS is to be designed to allow proper access for inspection maintenance and repair.

## 4 Equipment testing requirements

### 4.1 Machinery

#### 4.1.1 (1/6/2023)

The piping system of WAPS are subject to the testing requirements in Pt C, Ch 1, Sec 10, [21].

#### 4.1.2 (1/6/2023)

Hydraulic cylinders and pressure vessels are to be tested according to the requirements in Pt C, Ch 1, Sec 3.

#### 4.1.3 (1/6/2023)

Testing of electrical components are to be carried out according to the relevant requirements in Part C, Chapter 2, as applicable.

## 5 Tests on board

### 5.1 General

#### 5.1.1 (1/6/2023)

A detailed testing program is to be approved by the society and it is to include:

- mechanical and electrical installation visual inspection according to the approved drawings
- pre-sea trials tests with the scope to verify the correct functioning of all WAPS elements at quay
- sea trials with the aim to verify the safe operation of WAPS at different configurations

### 5.2 Pre-sea trials tests

#### 5.2.1 (1/6/2023)

These tests are to be performed before the commencement of the sea trials:

- WAPS piping system tightness tests according to Pt C, Ch 1, Sec 10
- WAPS automation commissioning according to Pt C, Ch 3, Sec 6, [4]
- WAPS electrical installation insulation resistance and earth according to Pt C, Ch 2, Sec 15, [3] and [4]
- WAPS machinery items functioning tests.

#### 5.2.2 (1/6/2023)

The tilting or retractable system functioning it to be verified for all operation modes and configurations foreseen for the use of WAPS elements.

### 5.3 Sea trials

#### 5.3.1 (1/6/2023)

These tests are to be performed out during the sea trials:

- recording of performances with WAPS on (active) and off (tilted or retracted) during navigation at established service speed of ship
- all operational modes and configurations of WAPS foreseen during navigation
- maneuverability tests with WAPS on (active) and off (tilted or retracted)
- emergency stop/shutdown of WAPS elements from control station according to [2.5.4].

#### 5.3.2 (1/6/2023)

After sea trials all relevant testing protocols are to be kept on board together with the operating and maintenance manual required in [3.1].

## SECTION 46

## ULTRA LOW EMISSION VESSEL (ULEV)

### 1 General

#### 1.1 Application

##### 1.1.1 (1/7/2023)

The additional class notation **ULEV** is assigned, in accordance with Pt A, Ch 1, Sec 2, [6.14.68], to new ships or to ships in service equipped with internal combustion engines with a very low level of emissions (both gaseous pollutants and particulate) tested at the time of assignment of the notation. The list of tested engines and their fuel(s) is to be recorded at the assignment of the **ULEV** additional class notation.

The requirements of this section apply to all internal combustion engines installed on board, except for:

- emergency engines (engines to be used only in case of emergencies)
- engines having a power  $\leq 19\text{kW}$ , except for
  - main engines; and
  - engines driving electric generators including emergency generator.

### 2 Definitions and Symbols

#### 2.1 Definitions

##### 2.1.1 Auxiliary engine (1/7/2023)

Auxiliary engine is an engine intended for driving electric generators not providing propulsion (directly or indirectly).

##### 2.1.2 Cycle (1/7/2023)

B-Type test cycles as detailed in ISO 8178-4 according to the type and operational speed of each engine, as defined in Tab 1.

**Table 1 : B-type ISO 8178-4 test cycles to be applied (1/7/2023)**

	Variable speed engine	Constant speed engine
Propulsion engine	E3	E2
Auxiliary engine	C1	D2

##### 2.1.3 ULEV sister ship (1/7/2023)

ULEV sister ship means a ship built by the same yard from the same plans, having engines, emission control system types and arrangements identical to the ones of the first ship in series.

##### 2.1.4 Emission control system (1/7/2023)

Emission control system is any device controlling or reducing emissions.

##### 2.1.5 Engine type (1/7/2023)

Engine type means a power source with defined essential characteristics according to Pt C, Ch 1, Sec 2, [1.5.1].

##### 2.1.6 Engine family (1/7/2023)

Engine family means a manufacturer grouping of engines which, through their design, have the same exhaust emission characteristics and comply with the applicable emission limit values.

##### 2.1.7 Engine operating mode (1/7/2023)

Engine operating mode is a configuration of the engine control system.

##### 2.1.8 Engine operating mode (1/7/2023)

Gaseous pollutants are the following pollutants:

- carbon monoxide (CO);
- total hydrocarbons (HC); and
- oxides of nitrogen (NO<sub>x</sub>) expressed as NO<sub>2</sub> equivalent.

##### 2.1.9 Internal combustion engine or engine (1/7/2023)

Internal combustion engine or engine are comprehensive (if installed) of the emission control system and the communication interface (hardware and messages) between the engine's electronic control unit(s) and any other powertrain or machinery control unit necessary to comply with the requirements of this notation.

##### 2.1.10 NO<sub>x</sub> Control Diagnostic system (NCD) (1/7/2023)

NO<sub>x</sub> Control Diagnostic system (NCD) is a system on-board the engine which is able of:

- detecting a NO<sub>x</sub> Control Malfunction
- identifying the likely cause of NO<sub>x</sub> control malfunctions by means of information stored in computer memory and/or communicating that information off-board.

##### 2.1.11 NO<sub>x</sub> control malfunction (1/7/2023)

A NO<sub>x</sub> control malfunction is an attempt to tamper with the NO<sub>x</sub> control system of an engine or a malfunction affecting that system that might be due to tampering. NO<sub>x</sub> control malfunctions include:

- impeded exhaust gas recirculation (EGR) valve,
- failures of the NO<sub>x</sub> Control Diagnostic (NCD) system.

##### 2.1.12 Parent engine (1/7/2023)

Parent engine is an engine selected from an engine family in such a way that its emissions characteristics will be representative for that engine family.

##### 2.1.13 Particle number or PN (1/7/2023)

Particle number or PN is the total number of solid particles emitted by an engine with a diameter greater than 23 nm.



### 2.1.14 Particulate Control Diagnostic system (PCD) (1/7/2023)

Particulate Control Diagnostic system (PCD) is a system on-board the engine which has a capability of:

- detecting a Particulate Control Malfunction,
- identifying the likely cause of particulate control malfunctions by means of information stored in computer memory and/or communicating that information off-board.

### 2.1.15 Particulate Control Malfunction (1/7/2023)

Particulate Control Malfunction is an attempt to tamper with the particulate after-treatment system of an engine or a malfunction affecting the particulate after-treatment system that might be due to tampering. Particulate Control Malfunctions include the types detailed in Tab 5.

### 2.1.16 Particulate matter or PM (1/7/2023)

Particulate matter or PM is a mixture of gas and solid particles emitted by an engine that is collected on a specified filter medium after diluting the gas with clean filtered air so that the temperature does not exceed 325 K (52°C).

### 2.1.17 Particulate pollutants (1/7/2023)

Particulate pollutants are any matter emitted by an engine that is measured as PM or PN.

### 2.1.18 Propulsion engine (1/7/2023)

Propulsion engine is an engine that provides power to move a ship through the water or directs the movement of a ship. For purposes of this section, "Propulsion engine" is interchangeable with "Main" engine.

## 2.2 Symbols

### 2.2.1 (1/7/2023)

N	: Engine speed, in r/min
$n_{hi}$	: Engine high speed, i.e. highest engine speed where 70% of the maximum power occurs
$n_{lo}$	: Engine low speed, i.e. lowest engine speed where 50% of the maximum power occurs
$n_{max}$	: 100% speed for the corresponding test cycle
P	: Engine power, in kW
$P_{max}$	: Maximum power in kW as designed by the engine manufacturer.

## 3 Documents to be submitted

### 3.1 Documents to be submitted for each engine

#### 3.1.1 (1/7/2023)

Documents to be submitted for each engine are listed in Tab 2.

**Table 2 : Documents to be submitted for each engine, if applicable, including the after-treatment system if installed (1/7/2023)**

No.	I/A (1)	Documents
1	I	Engine particulars, including exhaust after-treatment system particulars (e.g. Data sheet with general engine information, details of parameters, including engine components, settings and fuel specifications, that may influence the emissions of pollutants, Project Guide, Marine Installation Manual or installation recommendations)
2	I	Diagram of the reagent dosing system and associated control system
3	I	Emission monitoring system specification
4	I	Emission test program (engine or parent engine)
5	A	Emission test report (engine or parent engine)
6	I	Definition of the engine family and parent engine, and justification for the selection of the parent engine (for each engine's test report, if applicable)
7	I	Accreditation certificate of the testing laboratory or other document showing compliance with [5.2.2]
8	I	Engine maintenance manual, including after-treatment system maintenance manual
9	A	Technical details of additional components equipped to reduce the emission
<b>(1)</b> A = to be submitted for approval in four copies; I = to be submitted for information in duplicate.		

### 3.2 Documents to be submitted for the ship

#### 3.2.1 (1/7/2023)

Documents to be submitted for the ship are listed in Tab 3.

**Table 3 : Documents to be submitted for the ship (1/7/2023)**

No.	I/A (1)	Documents
1	I	List of all engines installed on board including their purpose and serial number
2	I	General arrangement of the engine, exhaust piping and exhaust after-treatment system on the first ship in series, if applicable, and on the ULEV sisters ship

(1) A = to be submitted for approval in four copies; I = to be submitted for information in duplicate.

## 4 Requirements

### 4.1 Engine testing

#### 4.1.1 (1/7/2023)

An engine type is to be tested according to the requirements described in [5] to demonstrate compliance with the requirements of [4.2]. No testing is required for engines having a type approval certificate in accordance with EU Regulation 2016/1628. In this case the relevant documentation is to be submitted.

#### 4.1.2 (1/7/2023)

An engine family member is compliant with the requirements of [4.2] if testing on a parent engine has been carried out satisfactorily. In this case the parent engine is to incorporate those features that will most adversely affect the pollutant emission level and it is to be chosen by the manufacturer. The parent engine is to have the highest gaseous and particulate pollutant emission level among all of the engines in the engine family.

Emission control systems are to be considered, if applicable, when parent engine and engine family are defined.

#### 4.1.3 (1/7/2023)

Engines installed onboard are compliant with the requirements of [4.2] if testing on a reference engine of the same design has been carried out satisfactorily. In this case the reference engine is to incorporate those arrangements on board that will most adversely affect the pollutant emission level.

The reference engine is to have the highest gaseous and particulate pollutant emission level among all of the engines of the same design installed on board.

Emission control systems are to be considered, if applicable, when the reference engine is defined.

#### 4.1.4 (1/7/2023)

Satisfactory testing carried out on the first ship in series may be considered by the Society as covering the engines installed on a ULEV sister ship. In this case it is to be demonstrated that engines, exhaust lines and emission control systems of the first ship in series are identical to the ones of the ULEV sister ship.

### 4.2 Emission threshold values

#### 4.2.1 (1/7/2023)

The emission threshold values for each engine installed on board, parent engine or reference engine based on measurements described in [5] are given in Tab 4.

**Table 4 : Emission threshold values for each engine installed on board, parent engine or reference engine based on measurements described in [5] (1/7/2023)**

Engine power range P (kW)	CO (g/kWh)	HC (1) (g/kWh)	NOx (g/kWh)	PM mass (g/kWh)	PN (1/kWh)
$19 \leq P < 75$	5,00	(HC + NOx $\leq$ 4,70)		0,30	-
$75 \leq P < 130$	5,00	(HC + NOx $\leq$ 5,40)		0,14	-
$130 \leq P < 300$	3,50	1,00	2,10	0,10	-
$P \geq 300$	3,50	0,19	1,80	0,015	$10^{12}$

(1) For gas fuelled engines and dual fuel engines in gas mode, the maximum allowable HC emission level is to be taken as the lower of:

- 6,19 and
- $0,19 + (9 \times \text{GER})$

Where GER is the average gas energy ratio over the test cycle defined in [2.1.2].

### 4.3 Emission control diagnostic

#### 4.3.1 NOx control diagnostic (1/7/2023)

A NOx Control Diagnostic system (NCD) able to identify NOx control malfunctions as defined in [2.1.11] and their likely causes is to be provided to electronically controlled engines using electronic control either to:

- determine both the quantity and timing of injecting fuel; or
- activate, de-activate or modulate the emission control system used to reduce NOx

This system is to be able to identify a detectable malfunction within 60 minutes (engine operation) and activate (if the case) a visual alarm in the engine control room. The system is to be able to identify the type of detected malfunction. The malfunction is to be recorded and stored by the NCD system in the onboard computer using a specific code.

#### 4.3.2 NOx reagent monitoring (1/7/2023)

The following parameters are to be monitored in case of NOx emission control using a reagent:

- a) reagent level in the storage tank
- b) reagent quality or concentration, or NOx concentration
- c) interruption of reagent dosing.

A visual alarm in the engine control room is to be activated in case of inadequate values (as defined by the Manufacturer of SCR) of parameters in point a) and b) or in case point c) and these incidents are to be recorded and stored in the onboard computer.

#### 4.3.3 Particulate control diagnostic (1/7/2023)

A Particulate Control Diagnostic system (PCD) able to identify the particulate control malfunctions as defined in [2.1.14] is to be provided in case of engines fitted with a particulate after-treatment system.

In case the same physical components (e.g. substrate, exhaust gas temperature sensor) are shared by the NOx control system and the particulate control system, they can be monitored by the NOx Control Diagnostic system only.

Tab 5 shows the maximum periods of engine operation that is allowed for the PCD system to detect a malfunction and identify it. In this case a visual alarm in the engine control room is to be activated and the malfunction is to be recorded under a specific code and stored in the onboard computer.

### 4.4 ULEV mode

#### 4.4.1 (1/7/2023)

For engines with several operating modes, at least one operating mode is to be compliant with the emission requirements of [4.2]. This operating mode is defined as "ULEV mode" and it is to be indicated in the engine manual and/or shipboard manual. The "ULEV mode" operation of the engine is to be recorded.

## 5 Emission measurement

### 5.1 Pollutants

#### 5.1.1 (1/7/2023)

Over the test cycle defined in [2.1.2], the brake specific emissions of the following pollutants are to be measured:

- Nitrogen oxides (NOx) in g/kWh
- Hydrocarbons, expressed as total hydrocarbons (HC or THC) in g/kWh
- Carbon monoxide (CO) in g/kWh
- Particulate matter (PM) in g/kWh
- Particle number (PN) in 1/kWh
- Carbon dioxide (CO<sub>2</sub> - for information only) in g/kWh.

### 5.2 Measurements

#### 5.2.1 Applicable standards (1/7/2023)

The requirements of ISO 8178 series are to be applied. The Society may accept similar recognized standards.

#### 5.2.2 Testing laboratories (1/7/2023)

Tests are to be carried out by independent laboratories accredited by a national accreditation body in accordance with ISO 17025 for the measurement of the required pollutants.

The Society may accept tests carried out by independent laboratories that are certified and/or recognized by a full member of the International Laboratory Accreditation Cooperation (ILAC) for the tests concerned. Laboratories that have not obtained certification or recognition as above may be accepted subject to certification or assessment by the Society in accordance with its "Rules for Recognition of Test Laboratories".

Measurements carried out by, or under the responsibility of, an Organization or body designated as a technical service as defined by EU Regulation 2016/1628 may also be accepted.

**Table 5 : Particulate after-treatment system malfunction types and maximum detection period (1/7/2023)**

Malfunction type	Period of engine operation within which the malfunction is to be detected and stored
Removal of the particulate after-treatment system	60 minutes of non-idle engine operation
Loss of function of the particulate after-treatment system	240 minutes of non-idle engine operation
Failures of the PCD system	60 minutes of engine operation

### 5.2.3 Location of Measurements (1/7/2023)

Measurements of the required pollutants may be carried out on board or at a testing facility and during the same trial. Each engine subject to measurement is to be tested separately.

### 5.2.4 Control points (1/7/2023)

In the case of electronically controlled engines using electronic control to:

- determine both the quantity and timing of injecting fuel; or
- activate, de-activate or modulate the emission control system used to reduce NOx

emission measurements are to be carried out at control points chosen randomly within the engine control area detailed in [5.5], and in a number indicated in Tab 6.

The brake specific emissions of NOx, HC, CO, PM and PN measured at each individual control point are not to exceed the limits given in Tab 4, multiplied by 2.

**Table 6 : Number of control points according to the purpose and operation of the engine (1/7/2023)**

	Variable speed engine	Constant speed engine
Propulsion engine	2	1
Auxiliary engine	3	1

### 5.2.5 Crankcase emissions (1/7/2023)

All crankcase emissions, namely:

- emissions normally routed into the exhaust after-treatment system; and
- emissions normally discharged to the atmosphere

are to be routed into the emissions sampling system for measurement purposes. Alternatively, crankcase emissions may be added by calculation.

## 5.3 Fuel specifications

### 5.3.1 Oil-fueled engines (1/7/2023)

Emission measurements as per [5.2] are to be carried out with the engine running on a fuel complying with ISO 8217 and with the engine manufacturer's specification. The fuel composition and properties are to be detailed in the test report.

### 5.3.2 Liquified natural gas fueled engines (1/7/2023)

Emission measurements as per [5.2] are to be carried out with the engine running successively on the reference fuels  $G_R$  and  $G_{20}$  (Tab 7 and Tab 8), without any manual readjustment to the engine fueling system between the two tests. One adaptation run is permitted after the change of the fuel.

**Table 7 : Composition of the reference fuel  $G_R$  (1/7/2023)**

Property	Unit	Min.	Max.
Molar fraction of methane	mol %	84	89
Molar fraction of ethane	mol %	11	15
Molar fraction of other components ( $N_2$ , $C_{2+}$ , other inert components)	mol %	-	1
Mass concentration of sulphur	mg/m <sup>3</sup>	-	10

**Table 8 : Composition of the reference fuel  $G_{20}$  (1/7/2023)**

Property	Unit	Min.	Max.
Molar fraction of methane	mol %	99	100
Molar fraction of nitrogen	mol %	-	-
Molar fraction of other components ( $C_2$ , $C_{2+}$ , other inert components)	mol %	-	1
Mass concentration of sulphur	mg/m <sup>3</sup>	-	10

The fuel composition and properties are to be detailed in the test report.

The Society may accept emission measurements carried out with the engine running on two fuels with a different composition from that of  $G_R$  or  $G_{20}$  in case  $G_R$  and  $G_{20}$  reference fuels are not available provided that:

- the gas fuel compositions comply with the specification of the engine manufacturer; and
- the impact of the composition of the gas fuel is properly documented based (e.g. test reports and engineering analysis).

### 5.3.3 Engines fueled with other fuels (1/7/2023)

Emission measurements as per [5.2] are to be carried out with the engine running on fuels complying with the requirements of ISO 8178-5 or of a similar recognized standard deemed acceptable by the Society.

The fuel composition and properties are to be detailed in the test report.

## 5.4 Deterioration factors

### 5.4.1 (1/7/2023)

To demonstrating compliance with the emission limits given in [4.2.1], the values measured according to [5.2] are to be multiplied by the deterioration factors described in Tab 9.

**Table 9 : Deterioration factors (1/7/2023)**

Pollutant	CO	HC	NOx	PM	PN
Deterioration factor	1,3	1,3	1,15	1,05	1,0

if the pollutant emission measurements are carried out on engines and after-treatment systems that have already been used for more than 10.000 hours, the deterioration factors need not to be applied.

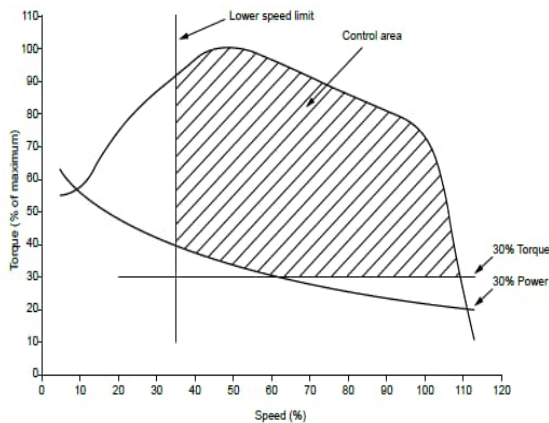
The Society may accept case-by-case deterioration factors established based on a suitable testing program accounting for ageing of the engine and exhaust after-treatment system for 10.000 hours as deemed acceptable by the Society.

## 5.5 Control areas

### 5.5.1 Variable speed auxiliary engines control area (1/7/2023)

Variable speed auxiliary engines control area is delimited by the following curves ( Fig 1):

**Figure 1 : Control area for variable speed auxiliary engines (1/7/2023)**



- upper torque limit: engine full load torque curve
- lower torque limit: 30% of maximum torque
- lower speed limit:  $n_{lo} + 0,15 \times (n_{hi} - n_{lo})$
- upper speed limit:  $n_{hi}$
- points below 30% of maximum net power are excluded from the control area.

In addition, for engines with maximum net power < 300kW and for particulate matter only, the following areas are excluded from the control area:

- if  $n_C < 2400$  r/min, points to the right of or below the line formed by connecting the points of 30% of maximum torque or 30% of maximum net power, whichever is greater, at  $n_B$  and 70% of maximum net power at  $n_{hi}$
- if  $n_C \geq 2400$  r/min, points to the right of the line formed by connecting the points of 30% of maximum torque or 30% of maximum net power, whichever is greater, at  $n_B$ , 50% of maximum net power at 2400 r/min, and 70% of maximum net power at  $n_{hi}$

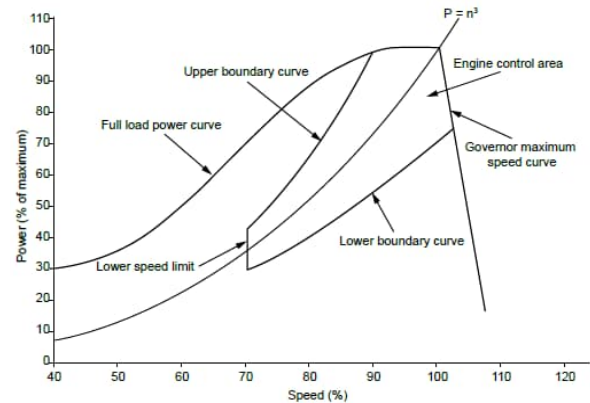
where:

$$n_B = n_{lo} + 0,5 \times (n_{hi} - n_{lo}) \quad n_C = n_{lo} + 0,75 \times (n_{hi} - n_{lo})$$

### 5.5.2 Variable speed propulsion engines control area (1/7/2023)

Variable speed propulsion engines control area is delimited by the following curves ( Fig 2):

**Figure 2 : Control area for variable speed propulsion engines (1/7/2023)**



- lower speed limit:  $0,7 \times n_{max}$
- upper boundary curve:  $P/P_{max} = 1,45 (n/n_{max})^{3,5}$
- lower boundary curve:  $P/P_{max} = 0,7 \times (n/n_{max})^{2,5}$
- upper power limit: full load power curve
- upper speed limit: maximum speed permitted by governor.

### 5.5.3 Constant speed propulsion and auxiliary engines control area (1/7/2023)

Constant speed engines control area is defined as follows:

- speed: 100%
- torque range: between 50% and 100% of the torque corresponding to the engine maximum power.

## 6 Surveys

### 6.1 Initial Survey

#### 6.1.1 (1/7/2023)

An initial survey is to be carried out by a surveyor before granting **ULEV** additional class notation. The survey is to verify that the general arrangement and engine particulars are consistent with the submitted documentation.

In particular, the following points are to be checked by the surveyor:

- proper operation of the NCD and PCD systems including the associated alarms; and
- proper operation of recording of the status of engines when operated in the ULEV mode.

# APPENDIX 1

# TEST PROCEDURES FOR COATING QUALIFICATION FOR WATER BALLAST TANKS OF ALL TYPES OF SHIPS AND DOUBLE-SIDE SKIN SPACES OF BULK CARRIERS

## 1 Scope

### 1.1

#### 1.1.1 (1/7/2006)

This Appendix provides details of the test procedures referred to in Sec 12, Tab 2 and Sec 12, [2.8.4].

## 2 Definitions

### 2.1

#### 2.1.1 (1/7/2006)

**Coating specification:** means the specification of coating systems, which includes the type of coating system, steel preparation, surface preparation, surface cleanliness, environmental conditions, application procedure, acceptance criteria and inspection.

## 3 Testing

### 3.1

#### 3.1.1 (1/7/2006)

Coating specification is to be verified by the following tests. The tests are to be carried out according to the procedures described in [4] - Test on simulated ballast tank conditions (see Fig 2) and [5] - Condensation chamber tests (see Fig 3).

#### 3.1.2 (1/7/2006)

Protective coatings for dedicated seawater ballast tanks are to comply with the requirements given in [4] and [5].

#### 3.1.3 (1/7/2006)

Protective coatings for double-side spaces of bulk carriers of 150 m in length and upwards, other than dedicated seawater ballast tanks, are to comply with the requirements given in [5].

## 4 Test on simulated ballast tank conditions

### 4.1 Test condition

#### 4.1.1 (1/7/2006)

The test on simulated ballast tank conditions is to satisfy each of the following conditions:

- a) The test is to be carried out for 180 days.
- b) There are to be 5 test panels.
- c) The size of each test panel is 200 mm x 400 mm x 3 mm. Two of the panels (Panel 3 and 4 below) have a U-bar Fig 1 welded on. The U-bar is welded to the panel at a distance of 120 mm from one of the short sides and 80 mm from each of the long sides.

Figure 1



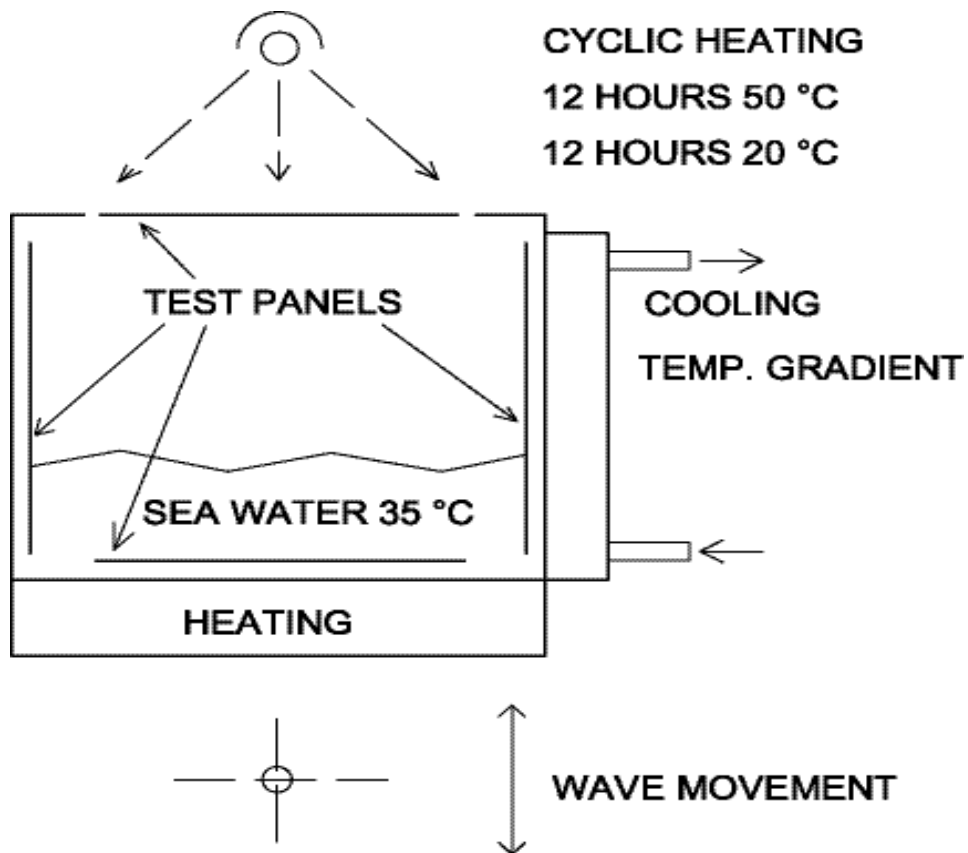
The panels are to be treated according to Sec 12, Tab 2, and the coating system applied according to items 1.d) and 1.e) of Sec 12, Tab 2. The shop primer is to be weathered for at least 2 months and cleaned by low pressure washing or other mild method. Blast sweep or high pressure washing or other primer removal methods are not to be used. The weathering method and extent are to take into consideration that the primer is to be the foundation for a 15-year target life system. To facilitate innovation, alternative preparation, coating systems and dry film thicknesses may be used when clearly defined.

- d) The reverse side of the test piece is to be painted appropriately, in order not to affect the test results.
- e) As simulating the condition of the actual ballast tank, the test cycle runs for two weeks with natural or artificial seawater and one week empty. The temperature of the seawater is to be kept at about 35°C.
- f) Test Panel 1 is to be heated for 12 hours at 50°C and cooled for 12 hours at 20°C in order to simulate upper deck condition. The test panel is cyclically splashed with natural or artificial seawater in order to simulate a ship's pitching and rolling motion. The interval of

splashing is 3 seconds or faster. The panel has a scribe line down to bare steel across width.

- g) Test Panel 2 has a fixed sacrificial zinc anode in order to evaluate the effect of cathodic protection. A circular 8 mm artificial holiday down to bare steel is introduced on the test panel 100 mm from the anode in order to evaluate the effect of the cathodic protection. The test panel is cyclically immersed with natural or artificial seawater.
- h) Test Panel 3 is to be cooled on the reverse side, so as to give a temperature gradient in order to simulate a cooled bulkhead in a ballast wing tank, and splashed with natural or artificial seawater in order to simulate a ship's pitching and rolling motion. The gradient of temperature is approximately 20°C, and the interval of splashing is 3 seconds or faster. The panel has a scribe line down to bare steel across width.
- i) Test Panel 4 is to be cyclically splashed with natural or artificial seawater in order to simulate a ship's pitching and rolling motion. The interval of splashing is 3 seconds or faster. The panel has a scribe line down to bare steel across width.
- j) Test Panel 5 is to be exposed to dry heat for 180 days at 70°C to simulate boundary plating between heated bunker tank and ballast tank in double bottom.

Figure 2 : Wave tank for testing of water ballast tank coating (1/7/2006)



**4.2 Test results**

**4.2.1 (1/7/2006)**

Prior to the testing, the following measured data of the coating system is to be reported:

- a) infrared (IR) identification of the base and hardener components of the coating;
- b) specific gravity, according to ISO 2811-74, of the base and hardener components of the paint; and
- c) number of pinholes, low voltage detector at 90 Volt.

**4.2.2 (1/7/2006)**

After the testing, the following measured data is to be reported:

- a) blisters and rust according to ISO 4628/2 and ISO 4628/3;
- b) dry film thickness (DFT) (use of a template) (see Sec 12, Tab 6);
- c) adhesion value according to ISO 4624;
- d) flexibility according to ASTM D4145, modified according to panel thickness (3 mm steel, 300 µm coating, 150 mm cylindrical mandrel gives 2% elongation) for information only;
- e) cathodic protection weight loss/current demand/disbondment from artificial holiday;
- f) undercutting from scribe. The undercutting along both sides of the scribe is measured and the maximum under-

cutting determined on each panel. The average of the three maximum records is used for the acceptance.

**4.3 Acceptance criteria**

**4.3.1 (1/7/2006)**

The test results based on [4.2] are to satisfy the acceptance criteria indicated in Tab 1.

**4.3.2 (1/7/2006)**

Epoxy based systems tested prior to the date of entry into force of Sec 12 are to satisfy only the criteria for blistering and rust in the table above.

**4.3.3 (1/7/2006)**

Epoxy based systems tested when applied according to Sec 12, Tab 2 are to satisfy the criteria for epoxy based systems as indicated in the table above.

**4.3.4 (1/7/2006)**

Alternative systems not necessarily epoxy based and/or not necessarily applied according to Sec 12, Tab 2 are to satisfy the criteria for alternative systems as indicated in the table above.

**Table 1 : Acceptance criteria of the results of test on simulated ballast tank conditions (1/7/2006)**

Item	Acceptance criteria for epoxy based systems applied according to Table 2 of Section 12	Acceptance criteria for alternative systems
Blisters on panel	No blisters	No blisters
Rust on panel	Ri 0 (0%)	Ri 0 (0%)
Number of pinholes	0	0
Adhesive failure	> 3.5 MPa Adhesive failure between substrate and coating or between coats for 60% or more of the areas	> 5.0 MPa Adhesive failure between substrate and coating or between coats for 60% or more of the areas
Cohesive failure	> 3.0 MPa Cohesive failure in coating for 40% or more of the area	> 5.0 MPa Cohesive failure in coating for 40% or more of the area
Cathodic protection current demand calculated from weight loss	< 5 mA/m <sup>2</sup>	< 5 mA/m <sup>2</sup>
Cathodic protection; disbondment from artificial holiday	< 8 mm	< 5 mm
Undercutting from scribe	< 8 mm	< 5 mm
U-beam	Any defects, cracking or detachment at the angle or weld will lead to system being failed.	Any defects, cracking or detachment at the angle or weld will lead to system being failed.



#### 4.4 Test report

##### 4.4.1 (1/7/2006)

The test report is to include the following information:

- a) name of the Manufacturer;
- b) date of tests;
- c) product name/identification of both paint and primer;
- d) batch number;
- e) data of surface preparation on steel panels, including the following:
  - surface treatment;
  - water soluble salts limit;
  - dust; and
  - abrasive inclusions;
- f) application data of coating system, including the following:
  - shop primed;
  - number of coats;
  - recoat interval (see Note 1);
  - dry film thickness (DFT) prior to testing (see Note 1);
  - thinner (see Note 1);
  - humidity (see Note 1);
  - air temperature (see Note 1); and
  - steel temperature;
- g) test results according to [4.2]; and
- h) judgment according to [4.3].

Note 1: Both actual specimen data and Manufacturer's requirement/recommendation.

## 5 Condensation chamber test

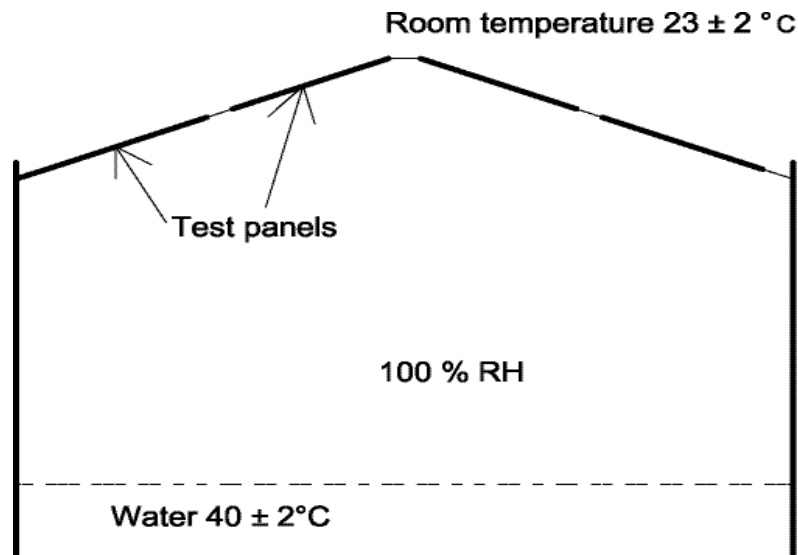
### 5.1 Test condition

#### 5.1.1 (1/7/2006)

The condensation chamber test is to be conducted in accordance with ISO 6270. The conditions are the following:

- a) The exposure time is 180 days.
- b) There are to be 2 test panels.
- c) The size of each test panel is 150 mm x 150 mm x 3 mm. The panels are to be treated according to Sec 12, Tab 2, and the coating system applied according to items 1.d) and 1.e) of Sec 12, Tab 2. The shop primer is to be weathered for at least 2 months and cleaned by low pressure washing or other mild method. Blast sweep or high pressure washing or other primer removal methods are not to be used. The weathering method and extent are to take into consideration that the primer is to be the foundation for a 15-year target life system. To facilitate innovation, alternative preparation, coating systems and dry film thicknesses may be used when clearly defined.
- d) The reverse side of the test piece is to be painted appropriately, in order not to affect the test results.

Figure 3 : Condensation chamber (1/7/2006)



**5.2 Test results**

**5.2.1 (1/7/2006)**

Prior to the testing, the following measured data of the coating system is to be reported:

- a) infrared (IR) identification of the base and hardener components of the coating;
- b) specific gravity, according to ISO 2811-74, of the base and hardener components of the paint; and
- c) number of pinholes, low voltage detector at 90 Volt.

**5.2.2 (1/7/2006)**

After the testing, the following measured data is to be reported:

- a) blisters and rust according to ISO 4628/2 and ISO 4628/3;
- b) dry film thickness (DFT) (use of a template) (see Sec 12, Tab 6);
- c) adhesion value according to ISO 4624;
- d) flexibility according to ASTM D4145, modified according to panel thickness (3 mm steel, 300 µm coating, 150 mm cylindrical mandrel gives 2% elongation) for information only.

**5.3 Acceptance criteria**

**5.3.1 (1/7/2006)**

The test results based on [5.2] are to satisfy the acceptance criteria indicated in Tab 2.

**5.3.2 (1/7/2006)**

Epoxy based systems tested prior to the date of entry into force of Sec 12 are to satisfy only the criteria for blistering and rust in the table above.

**5.3.3 (1/7/2006)**

Epoxy based systems tested when applied according to Sec 12, Tab 2 are to satisfy the criteria for epoxy based systems as indicated in the table above.

**5.3.4 (1/7/2006)**

Alternative systems not necessarily epoxy based and/or not necessarily applied according to Sec 12, Tab 2 are to satisfy the criteria for alternative systems as indicated in the table above.

**5.4 Test report**

**5.4.1 (1/7/2006)**

The test report is to include the same information required in [4.4] for the test report of the test on simulated ballast tank conditions.

**Table 2 : Acceptance criteria of the results of condensation chamber test (1/7/2006)**

Item	Acceptance criteria for epoxy based systems applied according to Table 2 of Section 12	Acceptance criteria for alternative systems
Blisters on panel	No blisters	No blisters
Rust on panel	Ri 0 (0%)	Ri 0 (0%)
Number of pinholes	0	0
Adhesive failure	> 3,5 MPa Adhesive failure between substrate and coating or between coats for 60% or more of the areas	> 5 MPa Adhesive failure between substrate and coating or between coats for 60% or more of the areas
Cohesive failure	> 3,0 MPa Cohesive failure in coating for 40% or more of the area	> 5,0 MPa Cohesive failure in coating for 40% or more of the area

## APPENDIX 2

## MOORING LOADS

### 1 General

#### 1.1 Application

##### 1.1.1 (1/7/2014)

Mooring loads are to be calculated from a direct mooring analysis conducted with appropriate recognized software calibrated and verified by model tests; in such cases where documented experience of previous similar projects does not require calibration/verification of the software, model tests could be omitted.

##### 1.1.2 (1/7/2014)

This Appendix specifies the requirements to be fulfilled in the most general case. The Society may accept relaxations to these requirements when deemed acceptable, at its discretion and on a case by case basis, depending on the unit's:

- seakeeping characteristics,
- area of operation,
- intended service.

### 2 Required documentation

#### 2.1 Unit and mooring data

##### 2.1.1 (1/7/2014)

The following information is required in order to assess the mooring analysis:

- Mooring system
  - Number of lines
  - Type of line segments
  - Weight of the chain
  - Arrangement of the fairleads for mooring lines
  - Fairleads and chain stopper drawings.
  - Dimensions
  - Material
  - Line length from fairlead to anchor point
  - Anchor pattern
  - Anchor type
  - Initial pretensions
  - Horizontal distance between fairleads and anchor point
  - Position of buoyancy elements and buoyancy of the elements
  - Position of weight elements and weight of the elements
  - Shackles, D-shackles
  - Anchor design including anchor size, weight and material

- Unit
  - Lines plan
  - Loading conditions
  - Characteristics of weight distribution (Moments of Inertia)
  - Arrangement of the fairleads for mooring lines
  - Fairleads and chain stopper drawings.

#### 2.2 Presentation of the results

##### 2.2.1 (1/7/2014)

The Mooring Analysis report should include, at least:

- Description of the software for the calculation and associated theory
- Description of the hydrodynamic model and mechanical model
- Calibration/comparison with model tests (or with previous experience) and model test evaluation
- RAO of the vessel motions (with input parameters specification in the case of non-linear/linearized analysis) and Quadratic Transfer Function of the unit
- Environmental data and wind combination matrix
- Assumptions and simplification
- Description of additional viscous damping, if applied
- Statistics of the results
- Spectral analyses of the results
- Time histories of the results.

### 3 Analysis methods

#### 3.1 Mooring analysis

##### 3.1.1 (1/7/2014)

The analysis is to reproduce, as closely as possible, the real behaviour of the system during its operative life.

Hypotheses assumed and simplifications made are to be clearly indicated and explained.

For the calculation of the forces induced by the mooring system on the unit, the following analyses are required:

- Quasi Static Analysis
- Dynamic Analysis.

##### 3.1.2 (1/7/2014)

Dynamic analysis can be:

- Frequency domain analysis (linear analysis) when non-linear effects are considered negligible
- Time domain analysis

Dynamic analysis is to be performed in the following conditions:

- Intact condition
- Broken line condition
- Transient broken line (required on a case by case basis)

The following effects shall be taken into account and sensitivity analysis shall be performed:

- Installation tolerances
- Chain length/pre-tension tolerances
- Chain corrosion
- Marine growth
- Water depth (tide/bathymetry) variation
- Waves period variation
- Seabed friction variation.

### 3.1.3 (1/7/2014)

Additional analyses may be required by the Society when deemed necessary.

## 4 Loads

### 4.1 General

#### 4.1.1 (1/7/2014)

The following effects are to be duly taken into account for the mooring analysis:

- Static loads
- Wind
- Current
- Waves (slow frequency and wave frequency motions).

#### 4.1.2 (1/7/2014)

The effects of wind, current and waves, considered as acting simultaneously, as described in [5], are to be considered.

### 4.2 Static loads

#### 4.2.1 (1/7/2014)

Static loads are the loads that act on the turret and on the hull in still water condition and with no wind and no current. Loads transmitted to the unit by external structures are due to the weight of the risers and to the pretension of the mooring lines.

### 4.3 Wind Loads

#### 4.3.1 (1/7/2014)

Wind loads may be determined by drag formulation considering drag coefficients according to recognised standards (such as OCIMF), where applicable, or through wind tunnel test or flow analysis.

For time domain analysis, time series of squalls according to wind spectrum, indicated in the meteo-marine data should be considered.

### 4.4 Current loads

#### 4.4.1 (1/7/2014)

The current loads may be determined according to recognised standards (such as OCIMF), where applicable, or

through wind tunnel test or flow analysis. For the evaluation of the current loads, current profile according to the information contained in the meteo-marine data is to be considered.

## 4.5 Wave loads

### 4.5.1 (1/7/2014)

The loads resulting from the interaction between waves and floating unit can be divided as follows:

- Wave frequency loads/motions
- Slow drift varying loads/motions
- Mean drift loads/mean displacement.

If no specific wave spectrum is indicated in the meteo-marine data, JONSWAP spectrum with spreading function  $\cos^4$  may be used. Peakedness parameter may be taken equal to 3,3 if not otherwise specified in the meteo-marine data.

## 5 Environmental conditions

### 5.1

#### 5.1.1 (1/7/2014)

All possible combinations of waves, current and wind that results in the most severe loading cases are to be accounted, as follows:

- 100-year waves with associated wind and current,
- 100-year wind with associated waves and current,
- 100-year current with associated waves and wind.

#### 5.1.2 (1/7/2014)

The data and the mutual direction of wind, waves and current should be extracted from meteo-marine data; if no data on the relative directions of wind, wave and current are available, different tests using conservative hypotheses (extreme cases) are to be considered.

## 6 Results and maximum expected value

### 6.1

#### 6.1.1 (1/7/2014)

A short-term analysis of the most critical cases is to be considered for the computation of the mooring loads.

The Characteristic Value of the mooring load to be considered for the strength assessment is the Maximum Expected Value for 3 hours return period in the most critical situation; a 3 parameter Weibull distribution may be used in order to fit the distribution of the "maxima between two mean-up-zero-crossing". The 3 parameter Weibull cumulative distribution function is represented by the following formula:

$$W(x) = 1 - \exp\left[-\left(\frac{x-m}{q}\right)^p\right]$$

Several 3 hour simulations with different random speeds or a long simulation should be run in order to provide good statistical confidence.

For the strength analysis, according to the Tasneef "Rules for the Classification of Floating Offshore Units at Fixed Locations and Mobile Offshore Drilling Units", Ch 7, 8 and 10, the most critical load combinations of hull girder loads, local loads and mooring loads are to be applied (dynamic loads characteristic values can be considered as equivalent static loads).

As guidance, the allowable displacement of the top of the riser should not be less than the maximum horizontal displacement of the unit.

## APPENDIX 3

# ADDITIONAL SYSTEMS, COMPONENTS AND OPERATIVE PROCEDURES TO EVALUATE THE BIOSAFE INDEX AS PER THE BIOSAFE NOTATION

### 1 Ship's General Arrangement

#### 1.1 Allocation of a dedicated area for the containment of a possible infection outbreak

##### 1.1.1 (1/1/2021)

The ship is to be designed to allocate an area for the containment of a possible infection outbreak (containment area).

The area, allocated as containment area, may be used for passengers and seafarers in normal conditions and is to be designed in such a way that it can be converted in the containment area in a short time in case of an outbreak on board or quarantine.

Number of cabins devoted to the containment area is to be at least one (1) percent of total cabins (passengers and seafarers' cabins) and in any case not less than ten (10) for passenger ships and at least one (1) for cargo ships. Cabins are to be located on the same deck and main vertical zone.

Evacuation routes are to be granted to and from the containment area. Evacuation routes and doors can eventually be sealed off with provisional means that can be easily removed in case of emergency (tapes, tarpaulins, etc) to grant the isolation. Tests, to demonstrate that means are easy to be removed, are to be carried out.

The containment area is to be provided with bulkhead or space subdivision with an "at full height" covering, disinfected and impermeable.

The containment area is to be provided with deck flooring washable and resistant to chemical and physical agents.

Oxygen storage and distribution to containment areas for therapeutic use is to be properly designed and arranged. Relevant risk assessment is to be performed accordingly.

Communication means (e.g. automatic telephone system) is to be provided in containment area.

Dedicated procedures are to be in place to address each step to make available the containment area and to dismiss it.

Ventilation system for containment area is to be in compliance with [5.1] or [5.2] or [5.3].

#### 1.2 Dressing and undressing areas

##### 1.2.1 (1/1/2021)

Dressing and undressing areas on the border of the containment area are to be implemented.

Isolation is to be ensured providing provisional means easily to be removed (e.g. tapes, tarpaulins, etc).

The dressing and undressing areas is to be provided with bulkhead or space subdivision with an "at full height" covering, disinfected and impermeable.

The dressing and undressing areas is to be provided with deck flooring washable and resistant to chemical and physical agents.

#### 1.3 Routes for medical care and containment areas

##### 1.3.1 (15/6/2020)

Two separate routes, one for infected or potentially infected persons (Dirty Route) and the other for medical personnel and ascertained non infected persons (Clean Route) are to be provided. Access points are to be the minimum possible.

Permanently installed means for sanitation of dirty routes are to be provided whenever they lead to or cross a clean route or a normal area.

#### 1.4 Dedicated area onboard for health monitoring centre

##### 1.4.1 (15/6/2020)

A dedicated area onboard is to be dedicated for the health monitoring centre, in order to manage processes related to the infection prevention, as health screening (i.e. temperature control), social distancing monitoring, passengers and seafarers' health data, sanitation monitoring, etc.

The health monitoring centre is to be located in a convenient place, as adjacent as possible to the hospital or other infirmary areas.

Procedures and operation, control, monitoring of the infection prevention systems implemented on board are to be available in the health monitoring centre, i.e.:

- Health Management Plan
- Containment areas communication and monitoring systems
- Passengers and seafarers' health data (locations visited before the embarkation, health conditions, health questionnaire)
- Temperature monitoring (i.e. gates and thermo-cameras data)
- Social distancing monitoring system

## 1.5 Routes for social distancing

### 1.5.1 (15/6/2020)

The ship is to be designed in order to ensure routes for maintaining social distancing during normal conditions.

Routes are to be considered for:

- boarding
- disembarkation
- access from and to vehicles decks, if any
- internal mobility to public spaces and to hallways for passenger and seafarer cabins
- routes for port workers
- routes for pilots.

Indication of dedicated routes are to be described in a dedicated plan and signposted onboard by means of walk-on labels, signs, permanently installed means clearly indicating the route and rules to be followed.

## 1.6 Routes for provision, luggage, spare parts management

### 1.6.1 (15/6/2020)

The ship is to be designed with routes for provisions, luggage, spare parts loading and management separated from routes for passengers.

Indication of dedicated routes are to be described in a relevant plan.

## 1.7 Working places

### 1.7.1 (15/6/2020)

Working places as bridge, engine control room, offices, workshops, changing rooms are to be arranged to grant the social distancing among seafarers.

Indication of the working positions are to be described in a relevant plan.

## 1.8 Corridors, stairs and lifts

### 1.8.1 (1/1/2021)

Corridors, stairs and lifts are to be designed for the practical passage of an enclosed stretcher.

## 2 Cabins and rooms

### 2.1 Cabins with enhanced sanitation capability surfaces

#### 2.1.1 (15/6/2020)

At least one (1) percent of total cabins (passengers and seafarers' cabins) are to be designed with shapes and proper materials to minimize the retention of infectious agents and to facilitate sanitation processes.

### 2.2 Rooms with fixed oxygen distribution

#### 2.2.1 (15/6/2020)

At least ten (10) rooms are to be equipped for the delivery of oxygen for medical purpose. Oxygen is to be stored in dedicated bottles and distributed with fixed installation. Relevant risk assessment is to be performed accordingly.

## 2.3 Rooms with direct alarm to medical care

### 2.3.1 (15/6/2020)

At least ten (10) rooms are to be equipped with the capability to activate an alarm at the medical care center.

The activation mean is to be easy to use and achievable from the bed in lying down position.

## 2.4 Information videos

### 2.4.1 (15/6/2020)

Information videos are to be broadcasted in passengers' cabins for infection prevention awareness by adequate means, e.g. cabin television.

Information videos are to be broadcasted in one or more languages likely to be understood by passengers, including children and individuals with disabilities.

## 3 Public spaces

### 3.1 Touch free/hands free solutions for means of access

#### 3.1.1 (15/6/2020)

Means of access to and within public areas are to be designed and operated in order to minimize the contact, i.e. touch free solutions or foot controls.

### 3.2 Touch free/hands free solutions for public toilets

#### 3.2.1 (15/6/2020)

Foot taps or automatic activation taps are to be provided in public toilets.

### 3.3 Surfaces with high utilization rate designed for easy sanitation

#### 3.3.1 (15/6/2020)

Surfaces with high utilization rate in public spaces such as door handles, handrails, seats, public toilet furniture, etc are to be designed with shapes and proper materials to minimize the retention of infectious agents and to facilitate sanitation processes.

### 3.4 Surfaces with high utilization rate active materials or coatings

#### 3.4.1 (15/6/2020)

Surfaces with high utilization rate in public spaces such as door handles, handrails, seats, public toilet furniture, etc are to be designed with active materials for disinfection and to minimize the retention of infectious agents, i.e. disinfectant paints, nanotechnology materials.

### 3.5 Public space design

#### 3.5.1 (15/6/2020)

Public spaces, including theatre, open decks, restaurants and cafeteria, swimming pools, jacuzzis, saunas, gyms, fitness centers, hairdressing and beauty centre, shopping areas, recreational activities areas are to be designed to minimize the risk of contamination and to grant social distancing.

Sneeze guards/barriers can be installed to enhance isolation among passengers and seafarers providing that materials are in compliance with applicable fire protection regulation and not obstruct escape routes.

Indication of dedicated passageways, tables, seats and areas are to be described in a dedicated plan and signposted onboard by means of walk-on labels, signs, permanently installed means clearly indicating the rules to be followed.

Permanently installed automatic dispensers of disinfectants in way of public space entrances, public toilets, restaurants, and lift stops (at each deck) are to be provided. Dispensers are to be touch free.

### **3.6 Onboard payments and contactless devices**

#### **3.6.1 (15/6/2020)**

Means to avoid contamination by cash are to be implemented such as enhanced electronic payment system or other alternative solutions.

#### **3.6.2 (1/1/2021)**

Means to avoid contamination by handling of menus, brochures etc. are to be implemented such as the use of personal electronic device for consulting and orders/reservations.

### **3.7 Information videos**

#### **3.7.1 (15/6/2020)**

Information videos are to be broadcasted in public areas for infection prevention awareness by fixed and dedicated means.

Information videos are to be broadcasted in one or more languages likely to be understood by passengers, including children and individuals with disabilities.

## **4 Prevention of contamination by surface**

### **4.1 UV-C lamps for surface disinfection**

#### **4.1.1 (15/6/2020)**

A room or a store equipped with a permanently installed UV-C lamps is to be provided.

The access door is to be capable to be closed only from outside the room and to be opened in any conditions from inside.

Means to avoid the presence of people when the UV-C lamps are in use are to be implemented (e.g. electrical interlock of the UV-C lamp supply with key door locked position and one other mean such as motion sensors, cameras, etc).

The above safety means are to be self-monitoring type in respect of internal failures. The system status is to be continuously monitored and any malfunctioning is to be immediately detected and managed with proper procedures. In the event of failure, an alarm is to be activated.

Effectiveness of UV-C lamp system is to be demonstrated by accredited laboratory analysis results.

### **4.2 Fixed or portable sanitation system**

#### **4.2.1 (15/6/2020)**

Fixed or portable sanitation systems for surfaces by means chemical agents are to be installed onboard.

Relevant procedures about their proper use are to be available.

Effectiveness of disinfection system on materials and surfaces is to be demonstrated by accredited laboratory analysis results.

### **4.3 Store for sanitation and disinfection products**

#### **4.3.1 (15/6/2020)**

At least one dedicated store for sanitation products is to be arranged on board. Category of the space is to be according to the materials stored inside. Compatibilities between chemical agents stored inside the same store is to be evaluated

A list of allowed chemical agents is to be prepared and clearly exposed inside the store.

### **4.4 Fixed sanitation system of dirty routes**

#### **4.4.1 (15/6/2020)**

Permanently installed means for sanitation of dirty routes are to be provided whenever they lead to or cross a clean route or a normal area.

Effectiveness of disinfection system on materials and surfaces is to be demonstrated by accredited laboratory analysis results.

## **5 Prevention of contamination by air**

### **5.1 HVAC system for containment area - independent system**

#### **5.1.1 (15/6/2020)**

A fully separate and independent ventilation system for containment area and relevant dressing and undressing areas is to be implemented.

All air handling units are to supply 100% outside air and no recirculation air is to be foreseen.

### **5.2 HVAC system for containment area - separated system**

#### **5.2.1 (1/1/2021)**

A ventilation system separable by means of dampers is to be implemented for containment area and relevant dressing and undressing areas. Supply air is to be 100% from outside and no recirculation air is to be foreseen. Manual actions necessary to implement the separation are to be indicated in a dedicated procedure.

### **5.3 HVAC system for containment area - under pressure isolation**

#### **5.3.1 (15/6/2020)**

Measures for maintaining in under pressure containment areas and relevant dressing and undressing areas (in respect



of all other adjacent spaces and external areas) are to be implemented. A minimum of six (6) fresh air changes per hour are to be ensured.

#### **5.4 HVAC system - air disinfection by means UV-C lamp**

##### **5.4.1 (15/6/2020)**

HVAC system air is to be treated by means of UV-C lamps permanently installed inside HVAC system.

Materials and coatings, if any, are to withstand the UV-C lamp effect.

Effectiveness of air disinfection is to be demonstrated by accredited laboratory analysis results.

#### **5.5 HVAC system - air disinfection by chemical agents**

##### **5.5.1 (15/6/2020)**

HVAC system air is to be treated by means of chemical agents deployed by systems permanently installed inside HVAC system.

Materials and coatings, if any, are to withstand the chemical agent effect.

Effectiveness of air disinfection is to be demonstrated by accredited laboratory analysis results.

#### **5.6 HVAC system - air disinfection by filters**

##### **5.6.1 (15/6/2020)**

HVAC system air is to be treated by means of filters installed inside HVAC system.

Filters effectiveness is to be in accordance with recognized international standards such as ASHRAE.

Effectiveness of air disinfection is to be demonstrated by accredited laboratory analysis results.

#### **5.7 Cabins - changes per hour**

##### **5.7.1 (15/6/2020)**

A cabin ventilation system having the capability to ensure at least six (6) fresh air changes per hour is to be ensured for each environmental condition.

HVAC system capability to ensure six (6) fresh air changes per hour for the maximum occupied cabins and for the design environmental conditions is to be demonstrated by means of relevant calculations.

#### **5.8 Public spaces - changes per hour**

##### **5.8.1 (1/1/2021)**

A public space ventilation system having the capability to ensure at least six (6) fresh air changes per hour is to be ensured for each environmental condition.

HVAC system capability to ensure six (6) fresh air changes per hour for the maximum occupied public spaces and for the design environmental conditions is to be demonstrated by means of relevant calculations.

#### **5.9 Cabins HVAC outlet**

##### **5.9.1 (15/6/2020)**

At least one (1) percent of total cabins (passengers and seafarers' cabins) are to be equipped with permanently installed air disinfection units based on UV-C lamp fitted on outlet of HVAC unit.

Effectiveness of air disinfection is to be demonstrated by accredited laboratory analysis results.

### **6 Prevention of contamination by fresh water system**

#### **6.1 FW disinfection by means UV-C lamp**

##### **6.1.1 (15/6/2020)**

Permanently installed water disinfection units for fresh water system based on UV-C lamps are to be provided.

Effectiveness of fresh water disinfection is to be demonstrated by accredited laboratory analysis results.

#### **6.2 FW disinfection by means chemical agents**

##### **6.2.1 (15/6/2020)**

Permanently installed water disinfection units for fresh water system based on chemical agents are to be provided.

Effectiveness of fresh water disinfection is to be demonstrated by accredited laboratory analysis results.

Effects of the chemical agents on human health is to be carefully evaluated.

### **7 Prevention of contamination by grey water and sewage system**

#### **7.1 Grey water disinfection**

##### **7.1.1 (15/6/2020)**

Permanently installed water disinfection units for grey water system are to be provided.

Effectiveness of grey water disinfection is to be demonstrated by accredited laboratory analysis results.

#### **7.2 Sewage disinfection**

##### **7.2.1 (1/1/2021)**

Permanently installed water disinfection units for sewage system based are to be provided.

Effectiveness of sewage disinfection is to be demonstrated by accredited laboratory analysis results.

### **8 Garbage Handling**

#### **8.1 Medical waste dedicated bins**

##### **8.1.1 (15/6/2020)**

Dedicated bins for special medical waste in hospital, containment areas and adjacent dressing and undressing areas are to be provided.

Relevant procedure for the management special medical waste are to be available.

## 8.2 Contaminated waste management

### 8.2.1 (15/6/2020)

Contaminated waste is to be kept on board in dedicated isolated locker.

Locker is to be marked with a dedicated label.

Dedicated procedures for waste managements and ashore disposal are to be available. Procedures have to include identification of specific routes and time schedule to ensure the safe distancing with other persons.

## 9 Enhanced medical care

### 9.1 Intensive care unit

#### 9.1.1 (15/6/2020)

A least one intensive care unit is to be arranged onboard. It is to be arranged in the hospital or containment area.

The intensive care unit is to be self-powered by internal batteries and by the transitional source of emergency electrical power.

Ventilation system, grey water and sewage system are to be independent.

The intensive care unit can be a containerized unit. In that case, the containerized unit is to be certified for safe use onboard.

### 9.2 Ventilators

#### 9.2.1 (15/6/2020)

Ventilators with invasive and non-invasive capabilities are provided to the ship.

Ventilators are to be self-powered by internal batteries and by the transitional source of emergency electrical power.

### 9.3 Totally enclosed stretcher

#### 9.3.1 (1/1/2021)

Totally enclosed stretcher is to be provided onboard to avoid contamination from infected persons during their transportation inside the ship.

### 9.4 Gastight coverall

#### 9.4.1 (15/6/2020)

A gastight coverall, to be used by trained medical personnel to care infected people, is to be provided.

## 10 Monitoring systems

### 10.1 People tracking system for social distancing monitoring

#### 10.1.1 (15/6/2020)

A tracking system of persons on board with the scope of monitoring concentration of people is to be provided.

It can be connected to the onboard systems as wi-fi, Bluetooth, RFID and is to be independent from ship's safety systems and is not to interfere with their functionality.

Passengers and seafarers are to be monitored by the tracking system using devices safe in terms of effect on human health (i.e. EMI) and in compliance with privacy rules.

### 10.2 Infected persons tracking system

#### 10.2.1 (15/6/2020)

A tracking system of confirmed infected persons on board is to be provided.

It can be connected to the onboard systems as wi-fi, Bluetooth, RFID and is to be independent from ship's safety systems and is not to interfere with their functionality.

Passengers and seafarers are to be monitored by the tracking system using devices safe in terms of effect on human health (i.e. EMI) and in compliance with privacy rules.

### 10.3 Gates for the automatic detection of potential affected people

#### 10.3.1 (15/6/2020)

Permanently installed gates for the automatic detection of potential affected people in access points (gangway, vehicles decks, etc) are to be provided. Gates are to be provided with thermo cameras or other means for checking people temperature during boarding phase. Gates are to be remotely controlled and monitored.

### 10.4 Containment areas monitoring

#### 10.4.1 (15/6/2020)

To check any unauthorized movement inside and from the containment area, a CCTV system and an alarm indicating the opening of each relevant door on the border of the containment area, are to be implemented. The alarms are to be given in a permanently manned position.

### 10.5 Equipment for distributed mustering

#### 10.5.1 (15/6/2020)

New technologies for mustering of the passengers (passengers muster drill) are to be installed onboard to grant the social distancing and to avoid assemblies.

Passengers muster drill is to be performed on board. Persons declaring a need for special care and children management are to be taken into account.

The technology is to ensure that all passengers are carrying out the drill (i.e. avoiding one person holding multiple devices). Any video broadcasted for this purpose is to include all mandatory requirements (specifics regarding medications, clothing, life jacket donning, etc).

The mustering system is to be approved by the Flag Administration.

### 10.6 Behaviour monitoring

#### 10.6.1 (15/6/2020)

Means to report people behaviour are to be permanently installed in public areas to report in real time any near-miss related to dangerous behaviours related to infection prevention, such as social distance not kept, personal protective equipment not properly worn, etc.

Information are to be managed in compliance with privacy rules.

## APPENDIX 4

# TEST PROCEDURES FOR COATING QUALIFICATION FOR CARGO OIL TANKS OF CRUDE OIL TANKERS

## 1 Scope

### 1.1

#### 1.1.1 (1/1/2023)

This Appendix provides details of the test procedures referred to in Sec 42, Tab 1.

Both the tank-top and deck-head are to be applied with coating systems that have passed the full test protocol as described in this document.

## 2 Definitions

### 2.1

#### 2.1.1 (1/1/2023)

**Coating specification:** means the specification of coating systems, which includes the type of coating system, steel preparation, surface preparation, surface cleanliness, environmental conditions, application procedure, acceptance criteria and inspection.

## 3 Testing

### 3.1

#### 3.1.1 (1/1/2023)

The tests herein are designed to simulate, as far as practicable, the two main environmental conditions to which the crude oil cargo tank coating will be exposed. The coating is to be validated by the following tests: the test procedures is to comply with [5] and [6].

## 4 Test gas composition

### 4.1

#### 4.1.1 (1/1/2023)

The test gas is based on the composition of the vapour phase in crude oil tanks, except that the hydrocarbon components are not included as these have no detrimental effect on epoxy coatings such as those used in cargo oil tanks.

**Table 1 : Test Gas Composition (1/1/2023)**

Item	
N <sub>2</sub>	83 ± 2 per cent by volume of dry gas
CO <sub>2</sub>	13 ± 2 per cent by volume of dry gas
O <sub>2</sub>	4 ± 1 per cent by volume of dry gas
SO <sub>2</sub>	300 ± 20 ppm
H <sub>2</sub> S	200 ± 20 ppm

### 4.2 Test liquid

#### 4.2.1 (1/1/2023)

Crude oil is a complex chemical material which is not stable over time when stocked. Crude oils can also vary in composition over time. In addition the use of crude oil has proven to create practical and HSE barriers for the involved testing institutes. To overcome this, a model immersion liquid is used to simulate crude oil. The formulation of this crude oil model system is given below:

- start with distillate Marine Fuel, DMA Grade, according to ISO 8217:2005, density at 15°C: maximum 890 kg/m<sup>3</sup>, viscosity of maximum 6 mm<sup>2</sup>/s at 40°C;
- add naphthenic acid up to an acid number, according to ISO 6618:1997, of 2.5 ± 0.1 mg KOH/g;
- add benzene/ toluene (1:1 ratio) up to a total of 8.0 ± 0.2% w/w of the DMA;
- add artificial seawater, according to ASTM D1141-98(2008), up to a total of 5.0 ± 0.2% w/w to the mixture;
- add H<sub>2</sub>S dissolved in a liquid carrier (in order to get 5 ± 1 ppm w/w H<sub>2</sub>S in the total test liquid);
- thoroughly mix the above constituents immediately prior to use; and
- once the mixture is completed, it is to be tested to confirm the mixture is compliant with the test mixture concentrations.

Note 1: To prevent the risk of H<sub>2</sub>S release into the test facility, it is recommended to use a stock solution for steps a) to d), then fill the test containers and complete the test solution with steps e) and f).

## 5 Gas-tight cabinet test

### 5.1 Test condition

#### 5.1.1 (1/1/2023)

The vapour test is to be carried out in a gas-tight cabinet. The dimensions and design of the air tight gas cabinet are not critical, provided the requirements of items f) to j) below are met. The test gas is designed to simulate the actual crude oil cargo tank environment in ballast condition as well as the vapour conditions of the loaded tank.

- a) The exposure time is 90 days.
- b) Testing is to be carried out using duplicate panels; a third panel is to be prepared and stored at ambient conditions to act as a reference panel during final evaluation of the test panels.
- c) The size of each test panel is 150 mm x 100 mm x 3 mm.
- d) The panels are to be treated according to Sec 43, Tab 1, item 1. b) and the coating system applied according to Sec 43, Tab 1, items 1.d) and 1.e).
- e) The zinc silicate shop primer, when used, is to be weathered for at least 2 months and cleaned by low pressure fresh water washing. The exact method of shop primer preparation before being over coated is to be reported, and the judgement issued for that specific system. The reverse side and edges of the test piece are to be coated appropriately, in order not to influence the test results.
- f) Inside the gas-tight cabinet a trough is to be present. This trough is to be filled with  $2 \pm 0.2$  l of water. The water in the trough is to be drained and renewed prior to each time the test gas is refreshed.
- g) The vapour spaces inside the gas-tight cabinet are to be filled with a mixture of test gas as per Sec 42, [2.5]. The cabinet atmosphere is to be maintained over the period of the test. When the gas is outside the scope of the test method, it is to be refreshed. The monitoring frequency and method, and the date and time for refreshing the test gas, are to be in the test report.
- h) The atmosphere in the test cabinet is to at all times be  $95 \pm 5\%$  relative humidity.
- i) Temperature of the test atmosphere is to be  $60 \pm 3$  C.
- j) A stand for the test panels is to be made of a suitable inert material to hold the panels vertically spaced at least 20 mm between panels. The stand is to be positioned in the cabinet to ensure the lower edge of the panels is at least 200 mm above the height of the water and at least 100 mm from the walls of the cabinet. If two shelves are in the cabinet, care is to be taken to ensure solution does not drip on to the lower panels.

### 5.2 Test results

#### 5.2.1 (1/1/2023)

Prior to testing, the following measured data of each coating composing the coating system, including the zinc silicate

shop primer when used under the coating system, is to be reported:

- a) infrared (IR) identification of the base and hardener components of the coating;
- b) specific gravity, according to ISO 2811-1/4:1997, of the base and hardener components of the paint; and
- c) mean dry film thickness (DFT) (by using the following template: six equally distributed measuring points are used on panels size 150 mm x 100 mm).

#### 5.2.2 (1/1/2023)

After completion of the test duration, the panels are to be removed from the cabinet and rinsed with warm tap water. The panels are to be dried by blotting with absorbent paper and, then, evaluated for rust and blistering within 24 h of the end of the test.

#### 5.2.3 (1/1/2023)

After testing, the following measured data is to be reported: blisters and rust (refer to ISO 4628:2003, ISO 4628-1:2003 and ISO 4628-2:2003).

### 5.3 Acceptance criteria

#### 5.3.1 (1/1/2023)

The test results based on App 1, [5.2] are to satisfy the acceptance criteria indicated in App 1, Tab 2.

#### 5.3.2 (1/1/2023)

When evaluating test panels, blistering or rusting within 5 mm of the panel edge is to be ignored.

**Table 2 : Acceptance criteria of the results of condensation chamber test (1/1/2023)**

Item	Acceptance criteria for epoxy-based systems	Acceptance criteria for alternative systems
Blisters on panel	No blisters	No blisters
Rust on panel	Ri 0 (0%)	Ri 0 (0%)

### 5.4 Test report

#### 5.4.1 (1/7/2006)

The test report is to include the following information:

- a) coating manufacturers' name and manufacturing site;
- b) dates of test;
- c) product name/identification of each coat and, where applicable, zinc silicate shop primer;
- d) batch numbers of each component of each product;
- e) details of surface preparation of steel panels, before shop primer application, and treatment of the shop primer before over coating where relevant and at a minimum including the following:
  - 1) surface treatment, or treatment of weathered shop primer, and any other important information on treatment influencing the performance; and
  - 2) water soluble salt level measured on the steel prior to application of the shop primer (refer to ISO 8502-6:2006 and ISO 8502-9:1998);

- f) details of coating system, including the following:
  - 1) zinc silicate shop primer if relevant, its secondary surface pre-treatment and condition under which applied, weathering period;
  - 2) number of coats, including the shop primer, and thickness of each;
  - 3) mean dry film thickness (DFT) prior to testing;
  - 4) thinner if used
  - 5) humidity;
  - 6) air temperature; and
  - 7) steel temperature;
- g) details of schedule for refreshing the test gas;
- h) test results according to [5.2]; and
- i) results according to [5.3].

## 6 Immersion test

### 6.1

#### 6.1.1 (1/1/2023)

The immersion test is developed to simulate the conditions in a crude oil tank in loaded condition.

- a) The exposure time is 180 days.
- b) The test liquid is to be made as per item 6 in the Standard.
- c) The test liquid is to be added to a container with an inside flat bottom until a column of the test liquid of height of 400 mm is reached, resulting in an aqueous phase of 20 mm. Any other alternative test set-up, using an identical test liquid, which will also result in the immersion of the test panel in 20 mm of the aqueous phase, is also accepted. This can be achieved by using, for instance, inert marbles.
- d) The temperature of the test liquid is to be  $60 \pm 2$  C and is to be uniform and maintained constant with recognized methods such as water or oil bath or air circulation oven capable of keeping the immersion liquid within the required temperature range.
- e) Test panels is to be positioned vertically and fully immersed during the test.
- f) Testing is to be carried out using duplicate panels.
- g) Inert spacers which do not cover the test area is to be used to separate test panels.
- h) The size of each test panel is 150 mm x 100 mm x 3 mm.
- i) The panels are to be treated according to Sec 42, Tab 1, items 1. b) and the coating system applied according to Sec 42, Tab 1, items 1.d) and 1.e).
- j) The zinc silicate shop primer, when used, is to be weathered for at least 2 months and cleaned by low pressure fresh water washing. The exact method of shop primer preparation before being over coated is to be reported, and the judgement issued for that specific system. The reverse side, and edges, of the test piece is

to be coated appropriately, in order not to influence the test results

- k) After the full immersion test period is completed the panels are to be removed from the test liquid and wiped with dry clean cloth before evaluation of the panels.
- l) Evaluation of the test panels is to be done within 24 h after completion of the test.

## 6.2 Test results

### 6.2.1 (1/1/2023)

Prior to testing, the following measured data of each coating composing the coating system, including the zinc silicate shop primer when used under the coating system, is to be reported:

- a) infrared (IR) identification of the base and hardener components of the coating;
- b) specific gravity, according to ISO 2811-1/4:1997, of the base and hardener components of the paint; and
- c) mean dry film thickness (DFT) (by using the following template: six equally distributed measuring points are used on panels size 150 mm x 100 mm).

### 6.2.2 (1/1/2023)

After testing, the following measured data is to be reported: blisters and rust (refer to ISO 4628:2003, ISO 4628-1:2003 and ISO 4628-2:2003).

## 6.3 Acceptance criteria

### 6.3.1 (1/1/2023)

The test results based on App 1, [5.2] are to satisfy the acceptance criteria indicated in App 1, Tab 2.

### 6.3.2 (1/1/2023)

When evaluating test panels, blistering or rusting within 5 mm of the panel edge is to be ignored.

## 6.4 Test report

### 6.4.1 (1/1/2023)

The test report is to include the following information:

- a) coating manufacturers' name and manufacturing site;
- b) dates of test;
- c) product name/identification of each coat and, where applicable, zinc silicate shop primer;
- d) batch numbers of each component of each product;
- e) details of surface preparation of steel panels, before shop primer application, and treatment of the shop primer before over coating where relevant and at a minimum including the following:
  - 1) surface treatment, or treatment of weathered shop primer, and any other important information on treatment influencing the performance; and
  - 2) water soluble salt level measured on the steel prior to application of the shop primer (refer to ISO 8502-6:2006 and ISO 8502-9:1998);

- f) details of coating system, including the following:
  - 1) zinc silicate shop primer if relevant, its secondary surface pre-treatment and condition under which applied, weathering period;
  - 2) number of coats, including the shop primer, and thickness of each;
  - 3) mean dry film thickness (DFT) prior to testing;
  - 4) thinner if used
  - 5) humidity;
  - 6) air temperature; and
  - 7) steel temperature;
- g) test results according to [6.2]; and
- h) results according to [6.3].

## 7 Precautions regarding the use of dangerous materials

### 7.1

#### 7.1.1 (1/1/2023)

The test methods involve the use of materials that may be hazardous to health as follows:

- a) Sulphur Dioxide: Corrosive when wet, toxic if inhaled, causes burns, and is an irritant to the eyes and respiratory system.
- b) Hydrogen Sulphide: Highly flammable (Flash point of -82°C), can form an explosive mixture with air, corrosive when wet, causes burns, has to be kept away from sources of ignition, irritant and asphyxiant, LTEL 5 ppm, STEL 10 ppm, higher concentrations can be fatal and have no odour. Repeated exposure to low concentrations can result in the sense of smell for the gas being diminished.

c) Benzene: Highly flammable (Flash point of -11 C), can form an explosive mixture with air, toxic, carcinogenic, acute health risk.

d) Toluene: Highly flammable (Flash point of 4 C), can form an explosive mixture with air, irritant, acute health risk, reprotoxin.

#### 7.1.2 (1/1/2023)

Special test apparatus and precautions may be required depending on the regulations in force in the country where the tests are carried out.

#### 7.1.3 (1/1/2023)

Although some countries have no specific requirements preventing either of the tests being carried out, it is to anyhow be required that:

- a) a risk assessment of the working conditions is carried out;
- b) during the test period, the system is to be enclosed; and
- c) the environment is to be controlled, particularly at the start and end of the tests, suitable air exhaust is to be available and personal protective equipment is to be worn.